

RADIO'S LIVEST MAGAZINE

Special  
Electronics  
Number

OVER 175 ILLUSTRATIONS  
RCA 85T-2E 3-2B  
#135-732-147  
**Radio-Craft**

HUGO GERNSBACK EDITOR

April  
25 Cents  
in United States  
and Canada

THE "ELECTRIC EYE"  
SPEED CHECKER

See Page 590

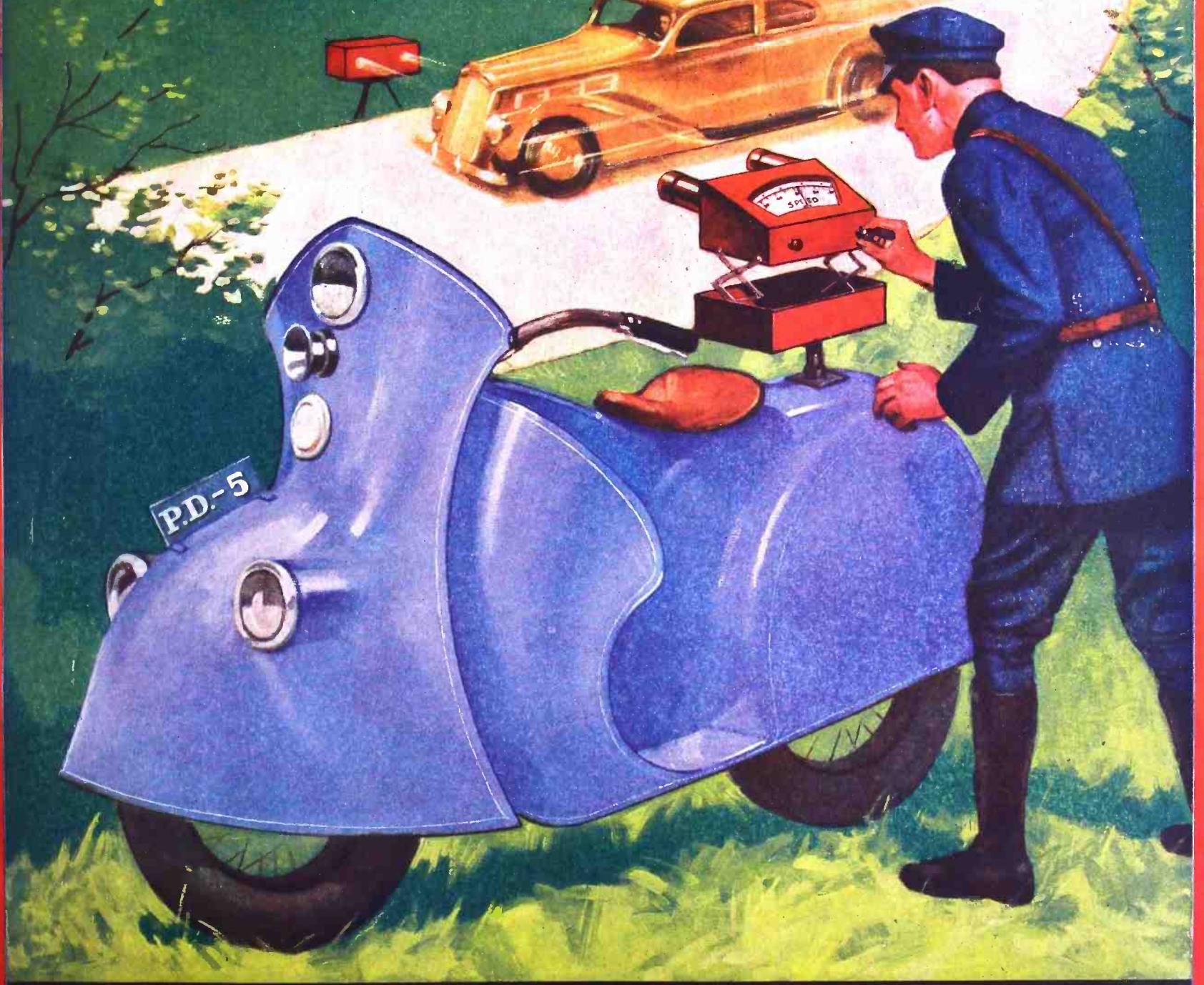

What About Radio in 1937? — March of Tubes — "Radio Kaleidochrome"  
Make these: Midget Oscilloscope; Standard Tube Tester; 1-Tube Set

OVER 50,000 RADIO MEN READ RADIO-CRAFT MONTHLY

RADIO SERVICE SHOP

**SUPREME** *Testing Instruments*



WRITE FOR DETAILS

*Designed by* SUPREME INSTRUMENTS CORP.

GREENWOOD  
MISSISSIPPI

**TRIPLED MY PAY**

Working steady... Making three times money I was... before I took up Coyne Training—Bert Farley.



**\$300 A MONTH**

Two weeks after graduation I had job with large Electrical Co. at \$300 a mo., with car furnished—H. C. Omer.



**THANKS TO COYNE**

I secured a position with an Electrical Construction Company, paying me three to four times more a week than I was getting before I entered Coyne—J. O. Whitmeyer.



**THOUSANDS are MAKING \$30-\$40-\$50 a WEEK in ELECTRICITY**

*Huge Developments Ahead*

**LEARN BY DOING — 12 WEEKS TRAINING IN BIG COYNE SHOPS**

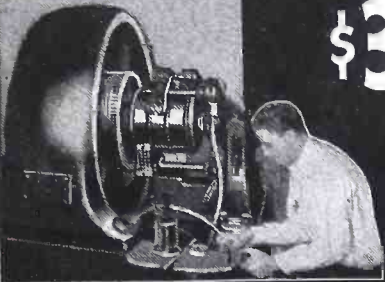

Thousands of Trained Electrical Men are making good money in the many branches of Electricity. Train for a better job—Right NOW!—whether you're 16 or 40. Look about you. Industry everywhere is being modernized with new electrical equipment—will use more ELECTRICITY. Many power plant operators now make up to \$50 a week. Electrical Maintenance Men are paid \$150 a month and up. Refrigeration and Air Conditioning Service Men earn \$30—\$40—\$50 a week. Armature winders make \$40 a week and more. Aviation Ignition Men also make good money at steady jobs. Many others operate their own business. These are only a few of the opportunities in Electricity.

COYNE extends the helping hand to YOU, too, if you're in a low-pay, discouraging job. Break out of the untrained class! If you are interested in bettering your place in life, get into ELECTRICITY—the gigantic growing field that employs more men than any other industry on earth!

**Train on FULL SIZE Equipment—NOT by Correspondence—NOT by Text Books**

COYNE Shop Training is NOT by correspondence or Home Study. You come right to the big COYNE Shops in Chicago to get this practical Training. You work on real equipment—such as generators, real dynamos, you wind armatures, work on diesel engines, airplane motors, and do many other practical Electrical jobs. Here is one of the greatest working outlays of its kind in America. No embarrassing reciting. No dry text books. You don't need high school education or previous experience. It is this real job Training that enables COYNE to train you for a better pay job.

**AIR CONDITIONING, DIESEL and ELECTRIC REFRIGERATION included**

Spreading over the nation is a vast network, these fast developing branches of ELECTRICITY are employing more men and paying more in salaries every year. Homes, offices, factories, trains, autos, airplanes are being air-conditioned. Autos may soon be diesel-powered. Instruction in these courses included without extra cost.



**YOU TRAIN HERE**  
Many thousands of dollars worth of real practical equipment and machinery is installed in our fireproof modern school.

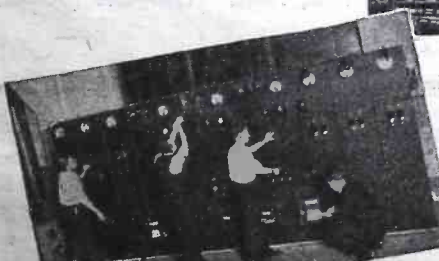

Many shop views like this shown in my catalog



**Send for EASY PAYMENT PLAN —New Low Cost Board and Room Plan**

My friend, don't waste the golden years of your life saying, "I can't afford Specialized Training!" Of course you can! Get my catalog—see for yourself how we help graduates year after year. I have a special new low cost Board and Room Plan whereby students take care of their living expenses while at COYNE. Get training first, then pay tuition in 18 easy, monthly payments, starting 5 months after you begin school. So don't let lack of money keep you from sending this coupon for full details of my amazing plans!

**PART TIME EMPLOYMENT**

If you need part time work to help pay living expenses while here, we'll help you. We help hundreds of students through this special department and may be able to help you.

**JOB AFTER GRADUATION SERVICE**

We keep in touch with many large firms in many branches of ELECTRICITY, ready at all times to supply their needs for trained men. After you graduate you get Lifetime job assistance through our Free Employment Department. As a COYNE graduate you get free business service and technical consultation to help you as you advance in your job; also, the privilege of review at any time without additional tuition charge.

**Employers PRAISE These COYNE Graduates**

"Mr. Lingerfelt's services very satisfactory. His practical shop training at COYNE has certainly helped increase his efficiency."

"John Lindquist was given an increase in salary due to the high quality of his work."

(Names of companies on request). We have scores of such letters. Get complete story. You owe it to yourself. Clip and send Coupon—NOW!

**GET FULL FACTS**

You'll see everything in the Big FREE COYNE Book... facts...opportunities...jobs... salaries...actual photos of hundreds of ambitious fellows preparing for better jobs. You'll see proof that COYNE training pays. This big Book is yours without obligation. So act at once. Just mail Coupon.



**MAIL THIS NOW for MONEY MAKING DETAILS**

H. C. LEWIS, President,  
COYNE ELECTRICAL SCHOOL,  
500 S. Paulina St., Dept. 47-78, Chicago, Ill.  
Without obligating me, send full details and your Big FREE Illustrated Catalog.

Name.....Age.....  
Street.....  
Town.....State.....  
Mail in Envelope or paste on Postcard

**COYNE ELECTRICAL SCHOOL**  
H. C. LEWIS, President  
500 S. Paulina Street. Dept. 47-78 Chicago, Illinois

Please Say That You Saw It in RADIO-CRAFT



HUGO GERNSBACK, Editor-in-Chief  
 C. W. PALMER Technical Editor  
 R. D. WASHBURNE, Managing Editor  
 C. P. MASON Associate Editor

Making the Radio Kaleidochrome—Color-Tuner—  
 Tone-Color Adapter.....Charles Sicuranza 604  
 Make This I-Tube "Home Broadcaster".....D. L. Warner 605  
 Here Is a General-Purpose Hi-Fi P.A. Amplifier  
 .....McMurdo Silver 605  
 Operating Notes..... 606  
 Make This Pocket-Size Meter Rectifier.....Milton Reiner 607  
 Practical Resistance and Capacity Decade Boxes  
 .....William H. Fritz 607

## CONTENTS-APRIL, 1937, ISSUE

Volume VIII Number 10

Editorial: Celestial Electronics.....Hugo Gernsback 581  
 The Radio Month in Review..... 582  
 Some of Radio's "400" Tube Types..... 584  
 What About Radio in 1937?..... 585  
 The March of Tubes.....C. W. Palmer 586  
 How to Make the RADIO-CRAFT Standard Tube  
 Tester ..... 588  
 "Electric Eyes" See All—Do All.....R. D. Washburne 590  
 "White" Is a Rainbow of Colors!.....  
 .....W. E. Reynolds and A. R. Hext 592  
 Phototubes and Photocells—When to Use Them  
 .....Earl D. Wilson 592  
 Questions and Answers About Electronic Music  
 .....Edward Kassel 593  
 International Radio Review..... 594  
 Make the RADIO-CRAFT Midget Oscilloscope—  
 Part I..... 595  
 How to Make the RADIO-CRAFT 1937 Television  
 Receiver—Part IV..... 596  
 Modern Short-Wave Diathermy—Part III  
 .....Leon C. Bunkin 598  
 The Latest Radio Equipment..... 599  
 Short-Wave Coils in a Jiffy—If You Use This Chart!  
 .....Raymond P. Adams 600  
 Direct-Coupling in a 30-W. Beam-Tube Amplifier!—  
 Part II.....A. C. Shaney 601  
 How to Use V.-T. Voltmeter in Radio and P.A.  
 Servicing—Part II.....Kendall Clough 601  
 Build This "2-in-1" Emergency Radio Set  
 .....N. H. Lessem 602  
 "Hurricane" Static!.....Joseph Weil 603  
 Improvements in the "12-Tube Hi-Fi Broadcast Re-  
 ceiver".....M. H. Gernsback 603

### RADIO SERVICE DATA SHEETS:

No. 195—Philco Model 37-620, 530 kc. to 7,35  
 mcs., 6-tube A.C. Superhet..... 608  
 No. 196—Emerson Models L117, L122, L133, L135,  
 L141, and L150 (Chassis Model L)..... 609  
 No. 197—RCA Victor Models 8BT, 8BT6, 8BK, and  
 8BK6 ..... 612  
 P.S.: "He Made the Sale!".....H. M. Bayer 610  
 ORSMA Members' Forum..... 610  
 Useful Radio Circuits..... 611  
 Technicians' Data Service..... 616

## THE MAY PUBLIC-ADDRESS NUMBER

—will contain information of importance not only to public-address specialists but also will prove to be an exceptionally interesting issue for the set builder, the Service Man, and the electronic technician.

"The Eternal Road"—the Max Reinhardt production that has set the theatre world agog—incorporates developments of prime importance to men in the sound field. The "whispering inter-phone" and other features in this production are described for *Radio-Craft* readers.

A 4-tube set, of simple design, that excels in tone quality is described for the set builder.

If it is scientific fiction you like, read "The Clairvoyant Dr. Fox."

Published by Radcraft Publications, Inc. Publication office: 29 Worthington Street, Springfield, Mass. Editorial and Advertising Offices: 99 Hudson Street, New York City. Chicago Advertising Office: L. F. McClure, 919 North Michigan Avenue, Chicago, Ill. Western Advertising Office: Loyd B. Chappell, 530 West Sixth St., Los Angeles, Calif.

#### Foreign Agents:

London—Gorrings American News Agency, 9A Green St., Leicester Square, W. C. 2, England.  
 Paris—Messageries Dawson, 4 Rue Faubourg, Poissonniere, France.  
 Melbourne—McGill's Agency, 179 Elizabeth St., Australia.  
 Dunedin—James Johnston, Ltd., New Zealand.

RADIO-CRAFT is published monthly, on the first of the month preceding that of date; subscription price is \$2.50 per year in U. S. and Canada. (In foreign countries, \$3.00 a year to cover additional postage.) Entered at the post office at Springfield as second-class matter under the act of March 3, 1879.

Text and illustrations of this magazine are copyright and must not be reproduced without permission of the copyright owners.

Copyright 1937. Radcraft Publications, Inc.

# Be a Radio Expert

Many make **\$30 \$50 \$75** a week

I will train you at home for many Good Spare Time and Full Time Radio Jobs



**J. E. SMITH, President, National Radio Institute**  
The man who has directed the home study training of more men for the Radio Industry than any other man in America.



**Set Servicing**

Spare time set servicing pays many \$5, \$10, \$15 a week extra while learning. Full time servicing pays as much as \$30, \$50, \$75 a week.

**Broadcasting Stations**

Employ managers, engineers, operators, installation and maintenance men for fascinating jobs and pay up to \$5,000 a year.

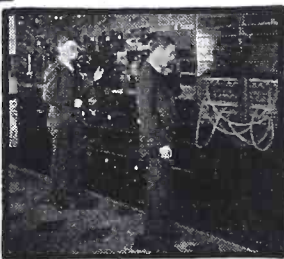

**Loud Speaker Systems**

Building, installing, servicing and operating public address systems is another growing field for men well trained in Radio.



**HERE'S PROOF THAT MY TRAINING PAYS**



**\$80 Monthly in Spare Time**

"I work on Radio part time, still holding my regular job. Since enrolling five years ago, I have averaged around \$80 every month." JOHN B. MORISSETTE, 773 Silver Street, Manchester, N. H.

**Makes \$50 to \$60 a Week**

"I am making between \$50 and \$60 a week after all expenses are paid, and I am getting all the Radio work I can take care of, thanks to N.R.I." H. W. SPANGLER, 308 Walnut St., Knoxville, Tenn.



**Operates Public Address System**

"I have a position with the Los Angeles Civil Service operating the Public Address System in the City Hall Council. My salary is \$153 a month." R. H. ROOD, R. 136, City Hall, Los Angeles, Calif.



**Lesson on Radio Servicing Tips—FREE**

I'll prove that my Training gives practical, money-making information, that it is easy to understand—that it is just what you need to master Radio. My sample lesson text, "Radio Receiver Troubles—Their Cause and Remedy" covers a long list of Radio receiver troubles in A.C., D.C., battery, universal, auto, T. R. F., super-heterodyne, all-wave, and other types of sets. And a cross reference system gives you the probable cause and a quick way to locate and remedy these set troubles. A special section is devoted to receiver check-up, alignment, balancing, neutralizing and testing. Get this lesson FREE. No obligation. Just mail coupon.

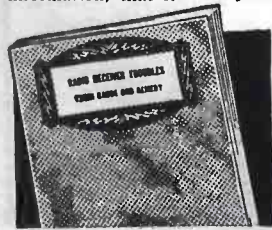

Do you want to make more money? Radio offers you many opportunities for well-paying spare time and full time jobs. And you don't have to give up your present job or leave home and spend a lot of money to become a Radio Expert.

**Many Radio Experts Make \$30, \$50, \$75 a Week**

Radio broadcasting stations employ engineers, operators, station managers and pay up to \$5,000 a year. Spare time Radio set servicing pays as much as \$200 to \$500 a year—full time jobs with Radio jobbers, manufacturers and dealers as much as \$30, \$50, \$75 a week. Many Radio Experts operate their own full time or part time Radio sales and service businesses. Radio manufacturers and jobbers employ testers, inspectors, foremen, engineers, servicemen, paying up to \$6,000 a year. Radio operators on ships get good pay and see the world besides. Automobile, police, aviation, commercial Radio, and loud speaker systems are newer fields offering good opportunities now and for the future! Television promises to open many good jobs soon. Men I have trained are holding good jobs in these branches of Radio. Read their statements. Mail the coupon.

**There's a Real Future in Radio for Well Trained Men**

Radio already gives jobs to more than 300,000 people. In 1935 over \$300,000,000 worth of sets, tubes and parts were sold—an increase of 20% over 1934! Over 1,100,000 auto Radios were sold in 1935, 25% more than in 1934! 22,000,000 homes are today equipped with Radios, and every year millions of these sets go out of date and are replaced with newer models. Millions more need servicing, new tubes, repairs, etc. Broadcasting stations pay their employees (exclusive of artists) more than \$23,000,000 a year! And Radio is a new industry, still growing fast! A few hundred \$30, \$50, \$75-a-week jobs have grown to thousands in less than 20 years!

**Many Make \$5, \$10, \$15, a Week Extra in Spare Time While Learning**

Practically every neighborhood needs a good spare time serviceman. The day you enroll

I start sending you Extra Money Job Sheets. They show you how to do Radio repair jobs that you can cash in on quickly! Throughout your training I send you plans that made good spare time money—\$200 to \$500 a year—for hundreds of fellows. My Training is famous as "the Course that pays for itself."

**I Give You Practical Experience**

My Course is not all book training. I send you special Radio equipment and show you how to conduct experiments and build circuits which illustrate important principles used in modern Radio receivers, broadcast stations and loud speaker installations. I show you how to build testing apparatus for use in spare time work from this equipment. This 50-50 method of training makes learning at home interesting, fascinating, practical.

**You Get a Money Back Agreement**

I am so sure that I can train you successfully that I agree in writing to refund every penny you pay me if you are not satisfied with my Lessons and Instruction Service when you finish. I'll send you a copy of this agreement with my Free Book.

**Find Out What Radio Offers You**

Act Today. Mail the coupon now for "Rich Rewards in Radio." It's free to any fellow over 16 years old. It describes Radio's spare time and full time opportunities and those coming in Television; tells about my training in Radio and Television; shows you actual letters from men I have trained, telling what they are doing and earning. Find out what Radio offers YOU! MAIL THE COUPON in an envelope, or paste on a postcard—NOW!

J. E. SMITH, Pres., National Radio Institute  
Dept. 7DX  
Washington, D. C.

**THIS FREE BOOK HAS HELPED HUNDREDS OF MEN MAKE MORE MONEY**

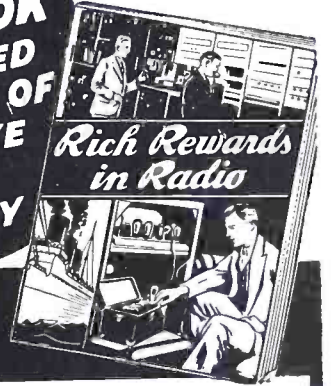

**This Coupon is Good For One FREE Copy of My Book**

J. E. SMITH, President, National Radio Institute, Dept. 7DX, Washington, D. C.

Without obligating me, send your service manual "Radio Receiver Troubles—Their Cause and Remedy" and free book about spare time and full time Radio opportunities and how I can train for them at home in my spare time. I am particularly interested in the branch of Radio checked below.

- Radio Service Business of My Own
- Spare Time Radio Service Work
- Retail Sales of Radio Sets and Equipment
- Service Expert for Retail Stores
- Broadcasting Station Operator
- Aviation Radio Operator
- Ship Radio Operator
- Loud Speaker Systems, Installation and Service
- Auto Radio Installation and Service
- Television Station Operator
- Designing and Constructing Testing Equipment
- Service Expert with Radio Factory
- Commercial Radio Station Operator
- All-around Servicing Expert.

(If you have not decided which branch you prefer—mail coupon now, for information to help you decide.)

NAME ..... AGE .....

ADDRESS ..... 14X-1

Please Say That You Saw It in RADIO-CRAFT

# RIDER MANUALS

Now in SEVEN Volumes

1600 PAGES

## VALUE...

*that Stands Out*

Like a Neon Sign on a dark street Rider Manuals stand out as the greatest manual value ever offered the radio serviceman. Complete information on radio receivers of over 350 different makes—7970 pages chock-full of pertinent service data on the greatest number of models ever compiled in one work—and all presented in a way that makes it easy to find *all of what you want when you want it*. . . . Over a hundred and thirty thousand volumes of Rider Manuals, now in use, testify to the tremendous value of these outstanding books in saving time—increasing profits—and guaranteeing success for the work of the radio serviceman. When you consider that your very next job may require the information contained in the very Rider manual you have “never gotten around to buying”—when you consider that your Rider Manuals can be kept up-to-date for *the profit from one additional tube sale a week*, you can see why we say, “You are taking unnecessary chances trying to ‘get by’ without a complete set of *seven* Rider Manuals”—the radio serviceman’s most inexpensive necessity.

Volume I—\$7.50—1920-31    Volume III—\$7.50—1932-33    Volume V—\$7.50—1934-35  
Volume II— 6.50—1931-32    Volume IV— 7.50—1933-34    Volume VI— 7.50—1935-36

**VOLUME VII—1600 PAGES—\$10.00 COVERING 1936-37.**

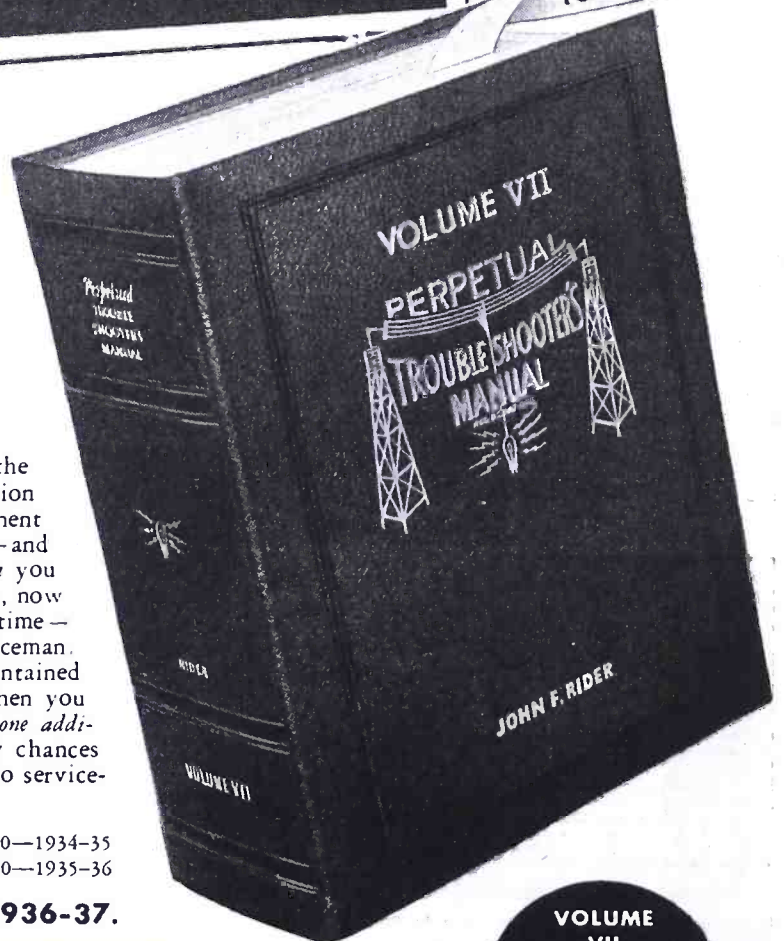

**VOLUME VII**  
*Published only four months ago  
Now in its third printing.*

**Volume VII contains complete service information on radio receivers produced by these 105 Manufacturers.**

*Compare this list before buying any manuals.*

- |                           |                        |                           |                   |                              |                    |                            |
|---------------------------|------------------------|---------------------------|-------------------|------------------------------|--------------------|----------------------------|
| A B C Radio Laboratories  | Buckingham Radio Corp. | Fairbanks Morse Federated | Horn Howard       | Pacific Packard Bell         | Sargent Co., E. M. | Turner Co.                 |
| Acratest                  | Cadillac               | Firestone                 | International     | Patterson                    | Sears Roebuck      | United Motors              |
| Air King                  | Capehart               | Freed                     | Interocean        | Peter Pan                    | Sentinel           | Universal Battery          |
| Allied                    | Case                   | Galvin                    | Jackson Bell      | Philco                       | Shelley            | Van Dyke                   |
| American Found. For Blind | Champion               | Gamble Skogmo             | Kennedy, Colin B. | Pilot                        | Simplex            | Warwick                    |
| Amrad                     | Climax                 | Garod                     | Kodel             | R C A                        | Sparton            | Wells Gardner              |
| Ansley                    | Continental            | Gates Radio & Supply Co.  | Lafayette         | R K Radio Laboratories, Inc. | Stewart Warner     | Western Auto               |
| Ariel Radio, Inc.         | Corona                 | General Electric          | Laurehk Mfg. Co.  | Radio Circular               | Stromberg Carlson  | Westinghouse E. & S.       |
| Atwater-Kent              | Crosley                | General Household         | Macy              | Radio Mfg. Engineers, Inc.   | Supreme            | Westinghouse International |
| Autocrat                  | Detrola                | Gilfillan                 | Majestic          | Radio Products               | T.C.A.             | Wilcox Gay                 |
| Automatic                 | De Wald                | Goodyear                  | Midwest           | Readrite                     | Tatro              | Wurlitzer Co., Rudolph     |
| Bosch                     | Electrad, Inc.         | Hallicrafters             | Mission Bell      | Radolek                      | Trav-Ler           | Zenith                     |
| Belmont                   | Emerson                | Halson                    | Monarch           | Remler                       | Triangle           | Zephyr                     |
| Brunswick Radio Corp.     | Espey                  | Hammarlund                | Montgomery Ward   | Republic                     | Triplet            |                            |
|                           | Fada                   | Hetro                     | Noblitt Sparks    |                              | Troy               |                            |
|                           |                        |                           | Operadio          |                              |                    |                            |

**ALL RIDER BOOKS ARE FOR SALE BY ALL GOOD RADIO JOBBERS.**

**JOHN F. RIDER, Publisher, 1440 BROADWAY, NEW YORK CITY**

*Please Say That You Saw It in RADIO-CRAFT*



"Takes the Resistance out of Radio"

Editorial Offices: 99 Hudson St., New York, N. Y.

HUGO GERNSBACK, Editor

Vol. VIII, No. 10, April 1937

## CELESTIAL ELECTRONICS

An Editorial by HUGO GERNSBACK

**W**HEN WE speak of the electronic art, we usually refer to electronics generated in various types of man-made vacuum tubes, which we use for exploiting various effects. Of such effects, scientists now know hundreds, and new uses for electronic tubes are found almost daily. Whether such tubes are used for television, whether they are used to open doors automatically as we approach them, whether we use them to assort beans or cigars, it is always the invisible electronic stream which is being used.

So when we contemplate these man-made electronic instrumentalities, we very often lose sight of the fact that *there is nothing new about electronics*. Indeed, it goes back for countless billions of years, since the first star was born.

But another and very curious point which I believe has never been described before is that the exact counterpart of an electronic tube actually exists not only in our own planetary system, but is probably duplicated myriads of times as well as in other universes throughout space.

Believe it or not, but the sun with the earth 93,000,000 miles distant is a remarkably efficient 3-element vacuum tube, similar to what we use in our radio sets. We have first the sun (the active cathode), far more efficient as an electron producer than anything we have ever produced on earth. As in the radio vacuum-tube filament, which is heated to incandescence, so the sun is also an incandescent body furnishing a steady yet invisible electronic stream which bombards the earth continuously, day in and day out, and has been doing so for countless millions of years. Scientists figure that the solar electronic stream takes about 26 hours to reach the earth from the sun. We know that this electron stream is not propagated at the speed of light—which is 186,000 miles a second—light, therefore, reaches us in some 8 minutes from the sun. Whenever there is a solar disturbance of any magnitude, the solar electronic emission is changed or varies (fluctuates) and we know about it 26 hours hence.

The atmosphere of our earth may be taken as the exact counterpart of the grid in an electronic tube. Our atmosphere is made up of gases, and the molecules composing these gases are of such magnitude that during the solar bombardment various electrical phenomena are produced. Thus, before the solar electronic emission reaches the earth's surface the latter may be compared to the anode or "plate" of our celestial vacuum tube (the interposing atmosphere is the "grid" and acts similar to the grid in a man-made vacuum tube).

This is easily proved by several examples. The earth is electrified by the solar emissions, which set up electric currents in the earth's crust. This gives the earth its 2 magnetic poles; one the north magnetic pole, the other the south magnetic pole. When the highly charged solar electrons hit the upper reaches of our atmosphere, certain electrical disturbances result and these disturbances make themselves known as the Northern Lights. Similar lights can be produced in any electronic tube under similar circumstances when the tube is *soft*, that is, when it has too much gas content. If the earth had no atmosphere, or gas, it would then also not have its "grid" and consequently we would have no "northern lights" as we now have them.

While this discussion may be of interest from a purely

theoretical viewpoint, I believe, it will also have its practical counterpart in the future, because here we have electronics on a large scale that can be investigated and important inferences drawn. Of course, there are many other electronic celestial phenomena which so far we have not made use of. Thus, for instance, we know that the tails of comets are only highly rarefied gases, much more rarefied than in our best electronic tubes. We also know that due to the electronic bombardment of the sun the tail of the comet always points *away* from the sun. Such phenomena we have duplicated in man-made tubes invented by Crookes and Nikola Tesla, but so far no practical application of these phenomena have been made.

When large sun spots appear, we have violent magnetic storms which cross through the earth's crust, interfering with telegraph and telephone communication and often putting both out of business for hours at a stretch. These disturbances are the aftermath of what happened on the sun and show the magnitude of the force.

We have produced large electronic tubes that due to the activity within them afford innumerable and varied results; however, we have not as yet succeeded in producing a "tube", or equivalent device, that permits us to achieve these results *outside* of the envelope. True, slight electronic activity may be obtained close to, and on the exterior of certain types of electronic tubes but, in a large sense, we have not yet mastered the secret of utilizing that electronic energy which is so abundant in our solar system and, in proportionate amount, on our earth. One practical consideration which such mastery of natural forces would involve is the problem of transmitting energy by radio; to solve it would open entirely new avenues of accomplishment of which we, today, do not even suspect the existence.

But most important is the tremendous fact that science as yet has made no effort at all to tap this titanic electrical force which comes to us through solar electronic streams day in and day out.

There is no question that the electronic stream which we thus receive from the sun is of such magnitude that if captured, electrical energy would be immediately available at a rate undreamed of today. As the force continues day in and day out unabated, it will be only a question of harnessing the electronic stream by suitable means to give us such cheap electrical power as we of today can not even imagine.

When electricity first became known, all dynamos and generators of the day, without exception, were driven by coal. A little later on we took to gasoline, (which we still use,) and then we started to make use of our water power with which to run our generators. The next great step in technical advance will be the scrapping of all generators of every type in favor of electronic power, collected by huge electrical devices, then to be transformed into usable electric current which will be dispatched over the usual high-tension wires to factories and the individual consumer.

While we are still a long way from this electronic millennium, the time is drawing nearer and nearer when all of the world's machinery and electricity will be dependent upon celestial electronics.

# THE RADIO MONTH



P.A. was used to talk to "sit-down" strikers.

## P. A. IN THE AUTO STRIKE

**E**LECTRONIC devices played their part last month in the strike demonstrations at several plants of the General Motors Corp. In one of the demonstrations, which raged through an entire night, a CIO organizer in a sound truck roared directions to the strikers, in spite of police gas-bombs and missiles.

At plant No. 2 of the Chevrolet Co. another labor organizer gave instructions to "sit down" strikers inside the plant, from the outside, by means of a car having a P.A. installation. Since there was no way to communicate with strikers, the P.A. voice was the only means of carrying on official business between the labor representatives and the "sit downers."

Public Address, it seems, has other uses than the usual ones of electioneering and voice magnification in auditoriums!

## H. F. MASSAGE HELPS POPE PIUS

**T**HE latest development of Guglielmo Marconi—a system of micro-wave therapeutics—was used successfully last month in the treatment of Pope Pius's ailing legs.

The process consists of electric massage using currents of extremely high frequency (in the micro-wave range). This treatment was effective not only in relieving the neuritis from which he was suffering but has also contributed in healing the greater part of his varicose leg ulcers, especially in the left leg, it was reported.

The differences in Marconi's diathermy equipment and those available in the U.S. were not pointed out in the reports received, but it is intimated that very much higher frequencies than normal were used.

The effectiveness of such treatments in certain types of ailments, however, was amply proven by the improvement in the Pope's condition after application.

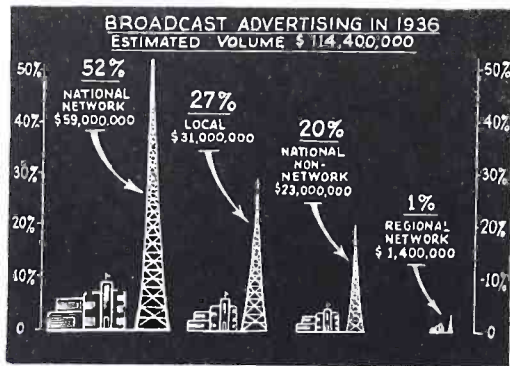

The sale of "commercials" mounted during 1936.

## RADIO BUSINESS IMPROVEMENT

**A**CCORDING to the latest radio bulletin from Dun and Bradstreet, Inc., the year 1936 was a banner one for all branches of radio.

According to this report: more than 1,400,000 sets were sold in homes not before radio-equipped; the total number of sets in the U.S. increased to nearly 25,000,000, of which 17,500,000 or 70 per cent are obsolete; over 7,600,000 sets were manufactured during 1936 and over 96,300,000 tubes were produced—both striking new peaks of production.

Although final figures for the 4th quarter of 1936 were not available at the closing of this issue, the magazine *Broadcasting* placed the gross time sales for commercial broadcasting at \$114,400,000, compared to \$95,678,425 recorded for 1935. And this marks the first time that the gross sale of time has exceeded the \$100,000,000 mark.

There has been a marked upswing in the prices of all radio equipment. Vacuum tubes which had been consistently reduced in price for years were increased sharply by an average of 11 per cent, last month. And many radio set manufacturers have also announced increases in the prices of sets which they have previously placed on the market, while new models are "up" in price by noticeable amounts.

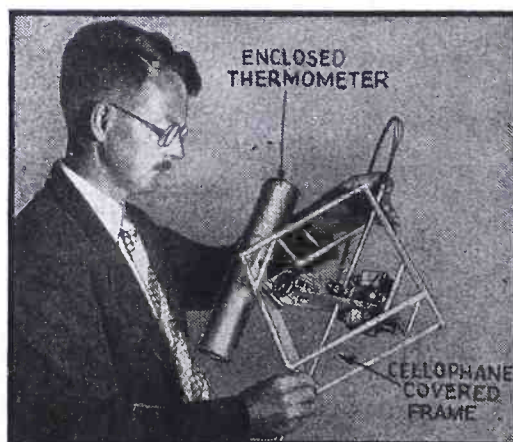

Dr. L. F. Curtiss holding a balloon transmitter.

## POWER FAILURE STOPS TUBE PRODUCTION

**T**HE recent interruptions in electric power in several cities points to the necessity for a complete re-examination of the power situation.

The indispensability of this source of power cannot be realized until an interruption such as the short-circuit in the Newark N.J. supply, last month, is experienced. The huge Newark airport was in darkness—the flying beams were off the air and mail and transport planes were forced to shift for themselves—traffic lights stopped working—industrial plants, including 2 radio-tube factories were forced to shut down—hospitals were without light and heat—and over half of the Newark district was illuminated by gas and candles.

Coming as it did only a few weeks after a similar failure in New York City—the situation certainly calls for some change to permit emergency service to be supplied, at least where it is vital to life and health!

Incidentally, all radio receiving sets were also silent, which illustrates the need for emergency radio equipment, as described on page 602 of this issue.

## RADIO METEOROGRAPHER

**S**OME interesting experiments conducted last month by Dr. L. F. Curtiss of the National Bureau of Standards promise to make possible long-range weather forecasting.

Tiny free balloons, equipped with automatic temperature recording and radio transmitting equipment weighing only 20 ozs., (complete) are sent soaring into the stratosphere. Radio messages from these balloons were received from distances as great as 80 miles.

The light weight of the transmitter is made possible by the development of the smallest "B" battery in the world—voltage, 45V.; weight, 2 ozs.; height, 2 ins.

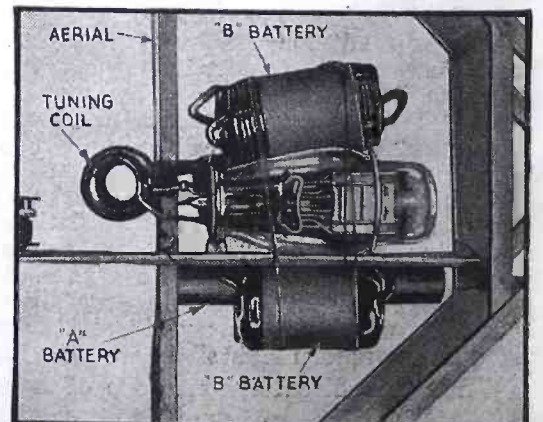

A close-up of the meteorograph transmitter.



# IN REVIEW

Radio is now such a vast and diversified art it becomes necessary to make a general survey of important monthly developments. RADIO-CRAFT analyzes these developments and presents a review of those items which interest all.

## RADIO AS A FLOOD AID

**T**HE unparalleled importance of radio, especially amateur radio, can be realized by the instructions issued by the F.C.C. last month, in connection with the devastating floods of the Ohio and Mississippi Rivers. The instructions read: "The F.C.C. has been advised that the only contact with many flooded areas is by amateur radio, and since it is of vital importance that communications with flooded areas be handled expeditiously, it is ordered that no transmissions except those relating to relief work or other emergencies be made within any of the authorized amateur bands below 4,000 kc. (75 meters) until the Commission determines that the present emergency no longer exists."

The broadcasting stations in the flooded areas have done their work in a commendable manner—especially at Louisville, Ky., where the authorities used the local stations WHAS and WAVE for communication with neighboring cities and towns for such calls as for police aid, vaccine, boats, fire fighting equipment and lights. Many of the stations in the affected area—notably WLW—placed their facilities at the disposal of the relief agencies.

## A 4,000-CELL PRISON RADIO

**I**NMATES of Jackson Prison, at Jackson Mich., can now enjoy all the comforts of home—even radio—during their enforced residence at the institution.

News was received, last month, that a new radio installation, the largest of its kind, has just been finished in the prison, to permit the inmates to enjoy radio broadcast programs. The equipment includes 3 channels which feed the 4,000 cells of the Michigan State Prison at headphone volume.



One of the prisoners enjoying the radio.

## THE MAXIM AWARD FOR AMATEURS

**I**N memory of their father, the late Hiram Percy Maxim, the son and daughter of the founder of the A.R.R.L. established, last month, an annual award to be given to the amateur under 21 years of age who has made the greatest contribution during the year to amateur radio.

The award is in the form of a gift of \$100 in cash and a miniature reproduction of the famous "Wouff Hong"—mythical implement of punishment for amateurs indulging in unsportsmanlike and unethical practices. Since the death of "The Old Man" the "Wouff Hong" has become a symbol of the principles and personality of the beloved patron of radio amateurs throughout the world.

## SOS ROBOT THREATENS RADIO OPERATORS

**A**N automatic radio operator to intercept SOS signals from distressed ships sent the American Radio Telegraphists Association into a furor last month, when Hoyt S. Haddock, president of the association sent a scorching letter to the F.C.C.

Mr. Haddock said: "It is our belief that the public should be thoroughly familiar with any device upon which their lives may depend, especially since it has been shown in the past that the auto-alarm has not been perfected and its use has caused loss of lives at sea."

While considering ship radio, it is interesting to note that the U.S. Public Health Service decided, last month, to grant medical clearance—the new radio signal "radio pratique"—to passenger ships into New York harbor, on the approval of the ship's doctor. This will expedite docking.



Jackson Prison officials with the receivers.

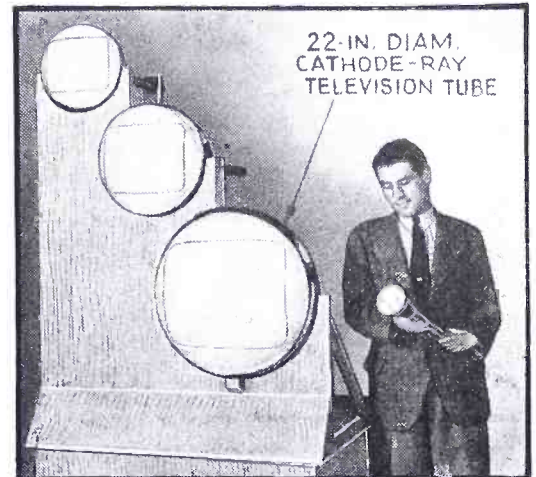

The world's largest C.-R. tube—22 ins. in diameter!

## TELEVISION NEWS SHORTS

**A**CCORDING to a report received from Philco last month, "British television is highly unsatisfactory and primitive and the received images are so distorted at times that arms and legs look like bags of sand."

Farnsworth Television, Inc., started field tests with a 1,000-W. transmitter in Philadelphia at the beginning of February. The transmitter scans at 441 lines, following the recommendations of the television committee of the R.M.A.

The British Broadcasting Corp. announced that they planned to build a "television van" to pick up images outside of Alexandra Palace. A coaxial cable will be stretched through the heart of London so that the images can be transferred to the transmitters.

The Federal Communications Commission, in its annual report to President Roosevelt, last month made the following statement:

"While the technique of television has progressed during the past year, it seemed the general consensus of opinion that television is not yet ready for public service on a national scale.

"There are numerous obstacles to be overcome and much technical development is required before television can be established on a sound national scale. Nevertheless, the rate of progress is rapid and the energies of the laboratories of the country are being concentrated on the development of television."

Sports made a play for consideration as an important part of the television programs in England, last month, when a group of boxing matches were transmitted, much to the delight of sports fans who crowded to capacity the various demonstration "theatres" in London's large stores and railroad stations.

There are now 8 manufacturers making television receiving sets in England, to receive the transmissions of Baird and the Marconi-E.M.I. systems. The sets sell for about \$400.00.

SOME OF

# RADIO'S "400"

TUBE TYPES

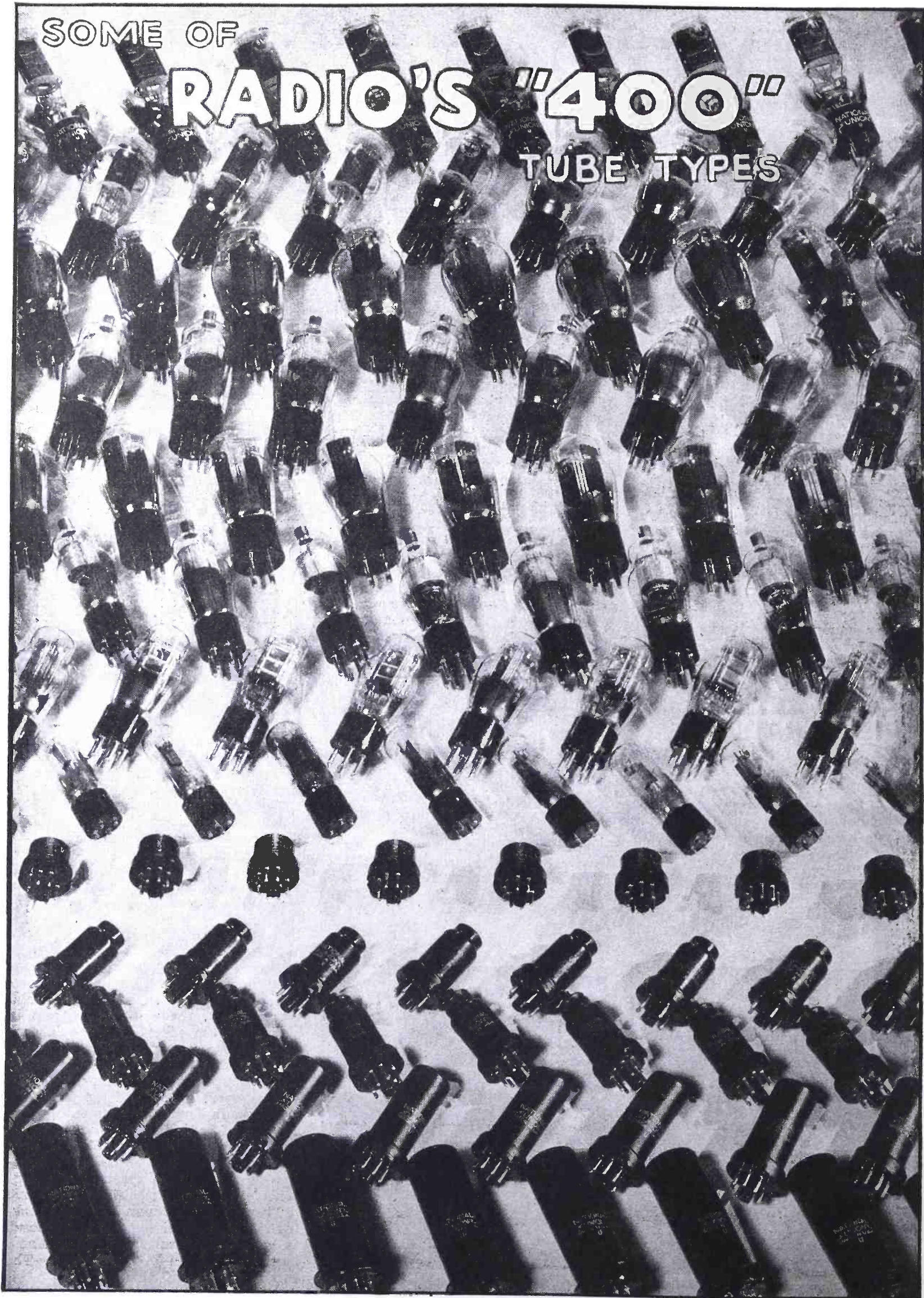

# WHAT ABOUT RADIO IN 1937?

INDUSTRIAL LEADERS IN THE RADIO INDUSTRY ANSWER 6 PERTINENT QUESTIONS ASKED BY RADIO-CRAFT CONCERNING THE FUTURE OF RADIO AS A PROFESSION FOR TRAINED MEN.

- (1) Will the Radio Industry benefit by a general improvement in business conditions throughout the country?
- (2) Is it your opinion that the Radio Industry faces even greater growth ahead than it has experienced to date?
- (3) Do you feel that the Radio Industry still offers opportunities to those who keep pace with its new developments and growth, as when the industry began?
- (4) Would you consider radio and its many branches a desirable vocation for a young man to choose as a permanent career today?
- (5) Do you believe that the Radio Industry will continue to need the services of competently-trained men?
- (6) What is your personal advice to young men who wish to become identified with the Radio Industry today?



**DAVID SARNOFF—**

Pres., Radio Corp. of America

- (1) Yes. (2) Yes. (3) Yes.
- (4) Our knowledge in radio is far less than our ignorance. The greatness of the art lies ahead and I therefore consider it peculiarly a young man's business.
- (5) Yes.
- (6) I would suggest preparation in the technical field because that is the best possible equipment for advancement and success in a career in radio work.

**COMM. EUGENE F. McDONALD—**

Pres., Zenith Radio Corp.

- (1) Naturally.
- (2) Yes, if the major manufacturers do not themselves destroy it.
- (3) Naturally not.
- (4) Yes, if he is properly qualified.
- (5) Yes.
- (6) Be sure that radio is the vocation you are best qualified for and intend to stay with.



**POWEL CROSLY, JR.—**

Pres., Crosley Radio Corp.

- (1) It is inevitable that the radio industry, along with all other industries, will benefit with a general improvement in business conditions in the country. Sales of 7 and 8 million sets a year are distinct possibilities. The average price of sets sold has increased materially to about \$65.00 for consoles and \$42.00 for table models. It is estimated that the sales of auto-radio sets
- (Continued on page 614)*

**ISIDOR GOLDBERG—**

Pres., Pilot Radio Corp.

- (1) Yes. More money will be spent for radio sets, and more money will be spent by sponsors for better programs.
  - (2) Yes. The average price of radio sets is increasing, new services will be provided by facsimile, calling for more transmitting and receiving equipment, and television development plans are being expanded.
  - (3) The number of salesmen, Service Men,
- (Continued on page 615)*



**L. E. GUBB—**

Pres., Philco Radio & Telev. Corp.

- (1) Yes. (2) Yes.
- (3) Yes, if engineering and merchandising keep up to date.
- (4) Yes. (5) Yes.
- (6) (No comment.)

**BENJAMIN ABRAMS—**

Pres., Emerson Radio Corp.

- (1) Judging by the attending increases during the past year, this may reasonably be expected.
- (2) Yes, with the idea of several sets to a home gaining ground all the time—and with new technical developments, better broadcasting, etc.
- (3) More so today than ever before.
- (4) Decidedly. As we learn more about the phenomena of radio the uses and opportunities they create will open up many new fields.
- (5) More so than ever before.
- (6) Take any sort of job, study the art and be prepared for the opportunities which are always arising.



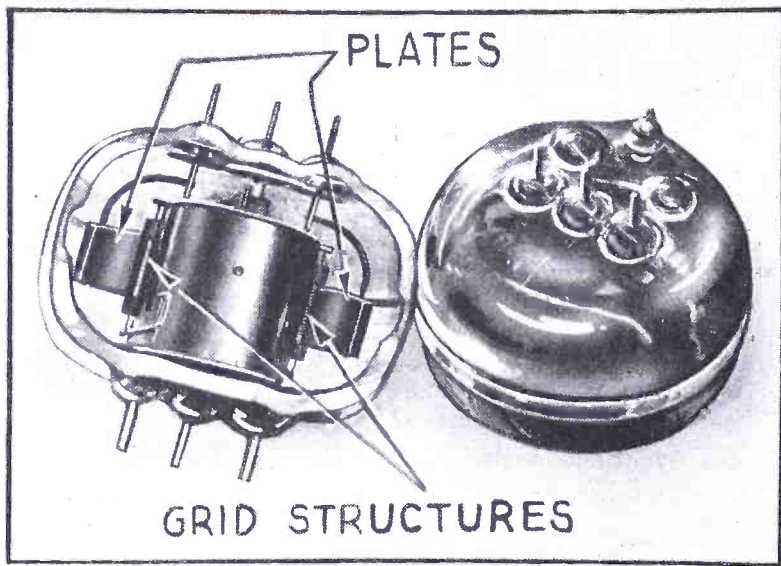

Fig. A. The new W.E. micro-wave dual pentode (so far, experimental).

# THE MARCH OF TUBES

The progress of the radio industry revolves around the vacuum tube. And every new radio innovation calls for new tubes—here are a few just added to radio's "400"!

C. W. PALMER

**E**LECTRONICS, that art of scientifically applying the forces and motions of electrons to do useful tasks, has had an astonishing history since the first evolution of the electron theory, a few decades ago. And perhaps the most astonishing of all is the rapid growth of the vacuum tube—that tiny glass or metal electronic relay—which is the very basis of the electronic art.

Every day, new uses are being found for these versatile "containers of nothing" and each new application calls for a vacuum tube of different design and construction than any previous type. It is only to be expected, therefore, that a large variety of tubes will be made to fill these varying needs—but few people realize the extent of these variations. A small idea of the number of tube types made can be gleaned from the fact that there are about 400 types of receiving tubes available in the U.S. alone, not counting the hundreds of experimental types which do not find ready application in sales to John Public!

Perhaps the outstanding happening in the field of electronic tubes this month is the announcement that the price of receiving tubes has been increased. For years, since the early tubes cost enthusiastic experimenters anywhere from \$10.00 to \$35.00 for a crude glass bulb having a somewhat haphazardly-placed filament, plate and grid, the price of tubes has been consistently on the down grade. However, in spite of improved mass production methods and mounting

sales, the price of tubes for receiving and amplifier uses has at last stopped its decline and an (average) increase of 11 per cent has been announced by the leading tube manufacturers.

From the standpoint of the dealer and Service Man, this announcement is an encouraging one, since it is the first step toward setting up a merchandising system which will allow a fair margin of profit in tube sales—which has not been the case for some time.

However, to leave the business end and look toward the technical side of the tube business, the engineers have not been twiddling their thumbs and sitting on past laurels—several new and useful tubes have been designed which will interest the radio fraternity.

### Push-Pull High-Frequency Pentode.

The Bell Telephone Labs. released a new tube to be used as an oscillator for ultra-high frequencies which is a step toward higher power on these "apex" frequencies. Because of the high-frequency possibilities of the tube it may have uses in television transmission.

The tube is made with 2 sets of elements inside a single thick glass envelope. These are connected to the external circuit to produce a balanced push-pull circuit having extremely short leads. Elaborate provisions have been made to shield the 2 pentode sections and very small spacing between the elements of each section is provided by careful manufacture. Long insulation paths permit using high plate voltages.

The result of this design increases the input resistance at 150 megacycles from about 1,000 ohms for the ordinary commercial tube to 30,000 for the new experimental tube. At 300 megacycles, the input resistance of the new tube is still 5,000 ohms while that of conventional tubes is so low as to make them inoperative.

When operated as a class A amplifier at 150 megacycles, an output of 1 W. is obtainable with the distortion 40 db. below the fundamental. Under these conditions the stage gain is 20 db. Outputs of 10 W. with a plate efficiency of 60 to 70 per cent at a gain of 20 db. are secured in class B operation.

The structural make-up of the new tube is shown in Fig. 1. The appearance can be seen in Fig. A. This tube is still in the experimental stages and has no official number or designation.

**0Z4G Full-Wave Gas-Filled Rectifier (Ionic-Heated-Cathode Type).** The 0Z4G was developed primarily for use in vibrator-type "B" supply units for automobile receivers, according to the Raytheon Production Corp. from which the characteristics were obtained. This tube has the typical characteristics of all gaseous rectifiers (old-timers will remember the BH and BA rectifiers of this type) as regards a constant internal voltage drop and ability to handle peak currents. In common with the older types of ionic-heated gas-filled tubes, the 0Z4G has a tendency to generate R.F. noise. This R.F. interference

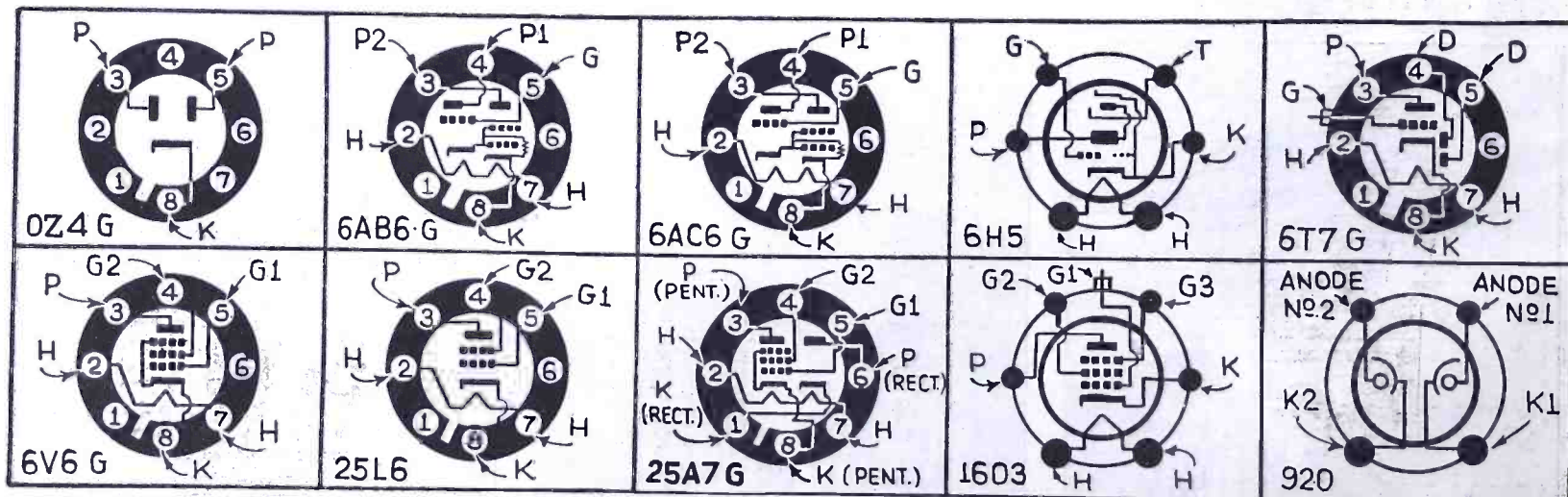

Fig. 2. The socket connections of the tubes described. Notice the complicated grid structures of some of the multi-element types.

can be eliminated by proper filtering and by connecting the metal shell to the point giving the best shielding. The shielding and filtering commonly used to eliminate vibrator noise will usually be sufficient.

This tube is available both in glass and metal types, both having octal bases. In the metal type, the metal shell serves chiefly as a container and electrostatic shield for the glass bulb which is required to insulate the contained gas from the grounded shell.

#### 0Z4G Characteristics

D.C. voltage output	300 max. V.
D.C. output current	30 min. ma.
	75 max. ma.
Peak plate current	200 max. ma.
Starting voltage	300 min. V.
	(peak)
Voltage drop (dynamic)	24 avg. V.

**5U4G Rectifier Tube.** This rectifier, according to a bulletin from Raytheon Production Corp., has similar characteristics to the glass rectifier—type 5Z3. It is equipped with an octal base though, instead of the older type.

**6A8, 6L7 and 6K7 Isolantite Grid Caps.** Also received from Raytheon, is news that the 3 types of tubes mentioned here are now fitted with isolantite insulation between the metal shell and the grid cap. This reduces R.F. losses at high frequencies, where the insulation resistance of most insulating materials falls off badly. The gain in short-wave and the high-frequency bands of all-wave receivers is definitely improved, according to the engineering report.

**6AB6G Dynamic-Coupled Power Tube.** Since the type 6B5 tube was developed early in 1935, many manufacturers of auto-radio sets have selected this unique tube for their higher priced sets. The unique qualities of the "dynamic coupling" which provide a high power sensitivity, yet with lower harmonic distortion than equivalent pentode types, added to the remote cut-off characteristic, made it a popular one.

The new 6AB6G was developed by

Triad Mfg. Co. to provide the industry with a tube having the characteristics of the 6B5 (which was designed for use in A.C. sets) but having a lower battery consumption and utilizing less space. The 6AB6G heater requires 0.5-A. at 6.3 V. This represents a 37 per cent reduction in heater power compared with the 6B5.

The 6AB6G is a strictly class A tube and as such, any of the high-resistance amplifiers may be used to supply the input signal; a grid resistor of 1 meg. is permissible under any operating conditions. When used in push-pull, the plate power can be reduced during periods of no-signal by connecting a self-bias resistor in the cathode lead (80 ohms) to introduce a 5 V. bias. This provides a semi-class AB operation in that plate current is reduced—but no driving power is required for this service.

#### 6AB6G Characteristics

Heater voltage	6.3 A.C. or D.C.		
Heater current	0.5-A.		
Amplifier (Class A)			
	Single	Push-Pull	
Output plate (P2)	250	250	max. V.
Input plate (P1)	250	250	max. V.
Grid	0	0	V.
Plate current (P2)	34	68	ma.
Plate current (P1)	5	10	ma.
Amplification factor	72		
Plate resistance	40,000		ohms
Mutual conductance	1,800		mmhos
Load resistance	8,000	10,000 p-p	ohms
Power output	3.5	8	W.
Harmonic distortion	10	6.5	per cent
Signal volts for rated power	18	42 g-g	r.m.s.
Push-Pull Amplifier (Class AB)*			
Output plate (P2)	245		max. V.
Input plate (P1)	245		max. V.
Self-bias resistor**	80		ohms
Zero-signal plate current (P2)	50		ma.
Full-signal plate current (P2)	68		ma.
Zero-signal plate current (P1)	8		ma.
Full-signal plate current (P1)	17		ma.
Load resistance	10,000 p-p		ohms
Power output	8		W.
Harmonic distortion	10		per cent
Signal volts for rated power	53 g-g		r.m.s.

Push-pull values are for 2 tubes.

\*Grid current does not flow during any part of the input cycle.

\*\*Common cathode resistor which is not bypassed. If this resistor is adequately bypassed or if a fixed bias of -5-V. is used, the class AB distortion is reduced nearly to that of the class A push-pull.

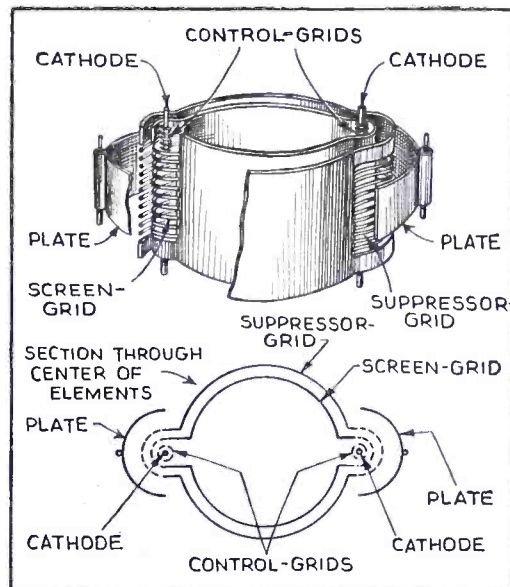

Fig. 1. The structure of the micro-wave tube.

The total resistance introduced into the grid circuit by the input coupling device should not exceed 1.0 meg.

**6AC6G Dynamic-Coupled Tube.** Like the 6AB6G, the new 6AC6G, also developed by Triad, is a twin-triode tube, dynamically-coupled within the envelope of the tube itself. This tube is similar to the well-known 6B5, but is designed for those small A.C. sets which operate with a low plate voltage (less than 180 V.) in conjunction with a series speaker field.

It is expected that a field of 700 to 800 ohms will be used as the filter choke, which will give both ample plate supply filtering and ample field power. A single tube used in this way will provide 4 W. of audio power at 10 per cent over-all harmonic distortion.

There will be no difficulty in providing sufficient input signal to the grid of the 6AC6G if the type 75 or 6Q7 voltage amplifier is operated with a plate voltage of 180. The resistance of the grid circuit may be as high as 1 meg. which is of importance in resistance-coupled A.F. systems. In some cases, the over-all sensitivity will be greater than in systems using a more sensitive output tube which requires a

(Continued on page 636)

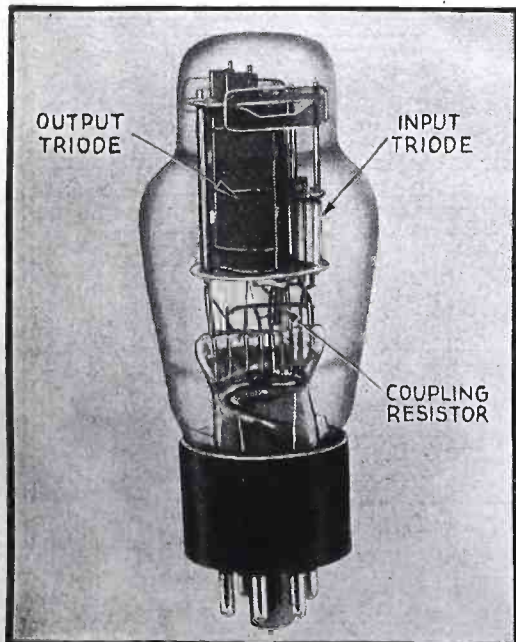

Fig. B. The types 6AB6G and 6AC6G look like this.

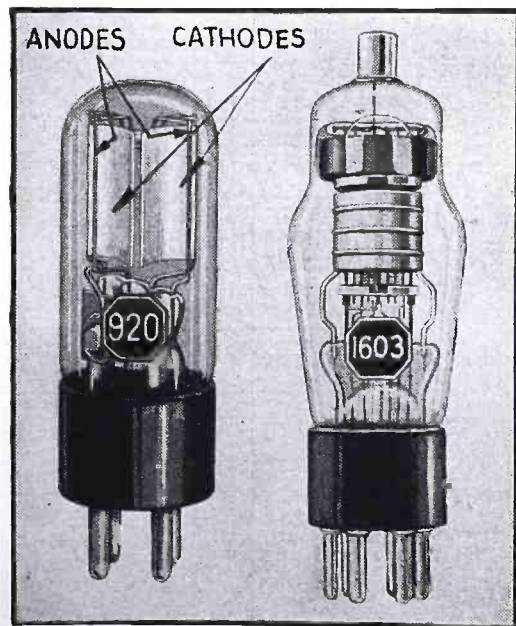

Fig. C. The 920 dual photo-tube and 1603 pentode. The latter is an excellent preamplifier.

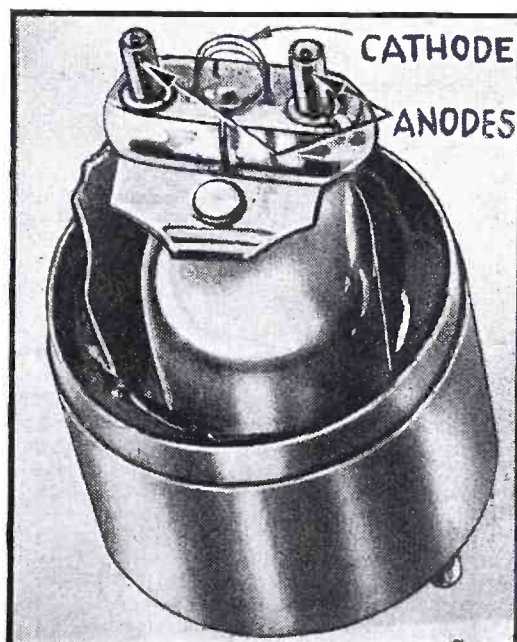

Fig. D. The 0Z4G ionic-heated cathode rectifier.

# HOW TO MAKE STANDARD

A standard tester which will accommodate all the tubes now available is not a luxury but an absolute essential to a successful service business. It also provides for new tubes.

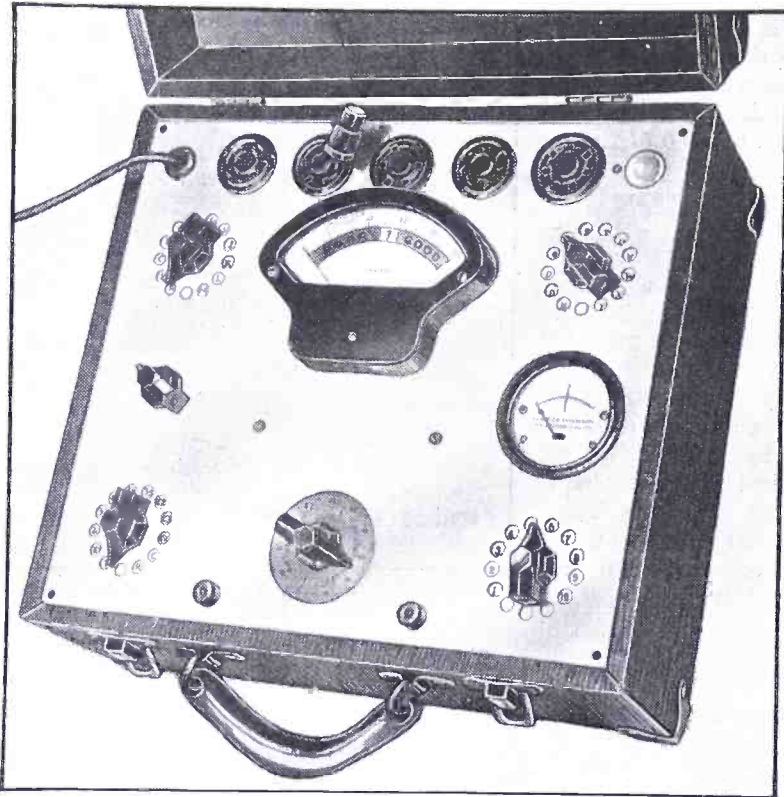

Fig. A. The front panel view of the unit in a portable case.

**T**HE PROBLEM of designing a tube tester that is professional in appearance without going to great expense is a difficult one. How well this design stacks up in appearance and performance can be gauged from an examination of the photographs and the actual operation of the completed unit.

## FEATURES OF THE RADIO-CRAFT STANDARD TUBE TESTER

- (1) English-reading meter.
- (2) Separate line-voltage meter and control.
- (3) Tests every type tube used today including octals and combination types.
- (4) Tests diodes and each section of combination-type tubes separately.
- (5) All elements can be tested for shorts and leakages.
- (6) Ohmmeter and continuity meter (no batteries).
- (7) Capacity tester measures capacity; indicates opens, shorts and leakage.
- (8) No adapters.
- (9) Extra spare switching capacity eliminates obsolescence.
- (10) Low cost.
- (11) Design permits mounting on test panel in lab. In portable case, or as a counter-type in the store.

## LIST OF PARTS

- One aluminum panel, 9 9/16 x 10 3/8 x 1/16-in.;
- One Dependable 0-5 ma. Milliammeter, 5 1/2 in. fan type, M1;
- One Dependable 0-25 V. A.C. iron-vane type, M2;
- One Dependable English-reading scale for M1;
- One Dependable line-set scale for M2;
- One Dependable 1-pole, 12-pos. selector, Sw.4;
- One Dependable 3-pole, 12-pos. selector, Sw.1, Sw.2;
- One Dependable 4-pole, 12-pos. selector, Sw.3;
- One Dependable fil.-plate transformer, P.T.;
- One Electrad 20-ohm wire-wound rheostat, R5;
- One Electrad 1,100-ohm dual rheostat, R1;
- One 1 W. carbon resistor, 10,000 ohms, R3;
- Two 1 W. carbon resistors, 20,000 ohms, R2, R8;
- Two 1 W. carbon resistors, 15,000 ohms, R7, R9;
- One 2 W. wire-wound resistor, 1,000 ohms, R4;
- One 2 W. wire-wound resistor, 1,400 ohms, R6;
- \*Five sockets:—one 4-prong; one 5-prong; one 6-prong; one octal; one 7-prong universal;
- \*One 2-in. etched scale, marked 0-100, 270 deg.;
- Six Allied Radio Corp. small bar knobs;
- One Allied Radio Corp. 8 ft. line cord and plug;
- \*One neon lamp, type N1;
- \*One universal insulated grid clip;
- \*One candelabra base for neon lamp;
- \*Two insulated tip-jacks—1 Red, 1 Black.

\*Names of manufacturers will be sent upon receipt of a stamped and self-addressed envelope.

One ingenious idea that cut the cost of the tester is the use of a plain aluminum panel. This panel was carefully drilled as indicated in Fig. 1, with a series of beveled 1/4-in. holes, located at each indicator marking position of the selector switches. Four pieces of white cardboard 2 3/8 ins. square with appropriate numbers and letters carefully drawn with india ink provided the scale markings for the various test positions. Transparent celluloid was used to cover the scales for protection from dust and damage.

Every part of the tester can be obtained from radio supply houses even to properly finished 2-color scales for the meter. If it is desired to make the scales for the meter in the lab. full details as shown in Fig. 2 can be followed.

## ASSEMBLY AND WIRING

The first step in constructing the tester is to lay out the panel very carefully for drilling. Cut the panel to the proper size and center-punch all holes as indicated in Fig. 2 especially those holes used as windows for the various identifying switch numbers and letters. Countersink these holes from the top of the panel so that a minimum of shadow will be cast on the letters by the side walls of the holes.

Wire-in the interconnections between the various switch taps before mounting the switches on the panel. This applies to the several sections of Sw.1, Sw.2 and Sw.3.

After the switch wiring is finished and checked start mounting all of the parts on the aluminum panel including the indicator scales. The proper placement of the parts can be checked from the bottom view photograph and the mechanical drawing. The electrical circuit drawing of Fig. 1 is so laid out that all of the parts are in their proper mechanical place as well as showing the electrical connections. Test for panel shorts between alive terminals and the insulated jacks with an ohmmeter.

The 2 sections of the dual rheostat R1 are connected in parallel when the tester is used on 110 V. A.C. lines.

Wire-in the 5 tube sockets as indicated to the selector switches. Check each lead at least twice.

Wire-in the leads from the power transformer to the

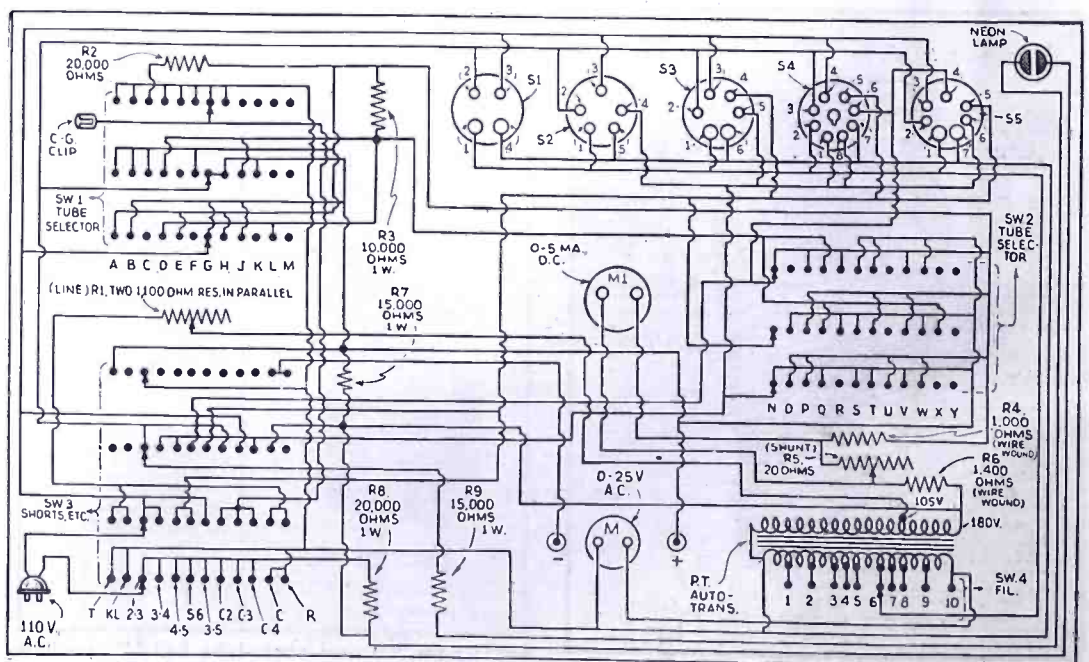

Fig. 1. The schematic circuit of the tube tester, and resistance and capacity meter.



# "ELECTRIC EYES"

Photoelectric or "PE." cells, by exhibiting capabilities in many fields of endeavor, are contributing materially to the business prosperity of these United States.

R. D.

**A** LADDIN had everything pretty much his own way, so to speak, what with being able to rub an old lamp and thereby summon a jinnee to do his every bidding. But Aladdin, were he able by some abracadabra of Mohammedan mythology to conjure himself into the year 1937, would hide his head in chagrin at the innumerable, and seemingly magical, results of which he never dreamed, but which with us have become almost commonplace—due to the versatility of the "electric eye."

In fact, it is not even necessary to move a hand—just a nod of the head and, flick, a bedridden invalid has caused a book's page to turn! Or, a bow before a white "altar"—an obeisance to the Prince of Magic, if you will—and lo, water gushes forth, in a fountain, for the thirsty!

But enough of this—*Radio-Craft* readers are familiar with these and many other tricks with the "electric eye" or light-sensitive photocell—it is the writer's desire to present in review a few of the more recent developments in the photoelectric field.

## MOBILE APPLICATIONS OF PE. CELLS

**The "Electric Eye" Auto-Speed Indicator.** On the cover of this issue of *Radio-Craft* is depicted in colors an artist's conception of the new RCA roadside vehicle speed indicator recently demonstrated by its inventor, F. H. Shepard, Jr. (The circuit of a *demonstration* set-up is given in Fig. 1.)

It will register a car's speed, in miles-per-hour, within a space of 1 ft. or less. As soon as the hood of a car going in one direction breaks the second parallel beam of light the car's speed—a miles-per-hour calibration of the instrument's voltmeter scale—is indicated; if the car is traveling in the opposite direction the reading is obtained when the rear end of the car breaks the second beam of light.

This electronic robot makes it unnecessary for motorcycle policemen to keep constantly on the go, "pacing" cars over considerable distances in order to determine their speed. The use of a second unit of this type placed about a half-mile away and arranged to flash red if the car is exceeding predetermined speed limits would serve as warning to the motorist and at the same time afford the officer an opportunity to "get set" in case his double-check indicated that a chase was necessary. (Fig. A)

**Photoelectric Car-Counters.** Motorists passing a certain point on a road in southern Illinois seldom are aware that an unusually interesting type of electronic car-counter is operating. Unlike single-beam counters, that are actuated by *any* object—person or automobile—that breaks the ray's path to the photocell, this counter totals *only* when a car passes a given point.

This distinction between car and person is accomplished by using 2 beams instead of 1, focused on 2 photocells instead of the customary individual cell; only a car is long enough to simultaneously break both beams.

**Push-Pull Photocells Detect Airplane.** An American, A. Fitzgerald, has demonstrated that photoelectric equipment may be utilized to indicate, in an experimental set-up, the presence of an airplane 3,000 ft. high and 1,000 ft. distant.

To accomplish this, 2 lens systems focus the 'plane's image on 2 checkerboards having alternately transparent and opaque squares. The equivalent square on the opposite board is opposite in transparency; that is, if a given square on one checkerboard is transparent the equivalent square

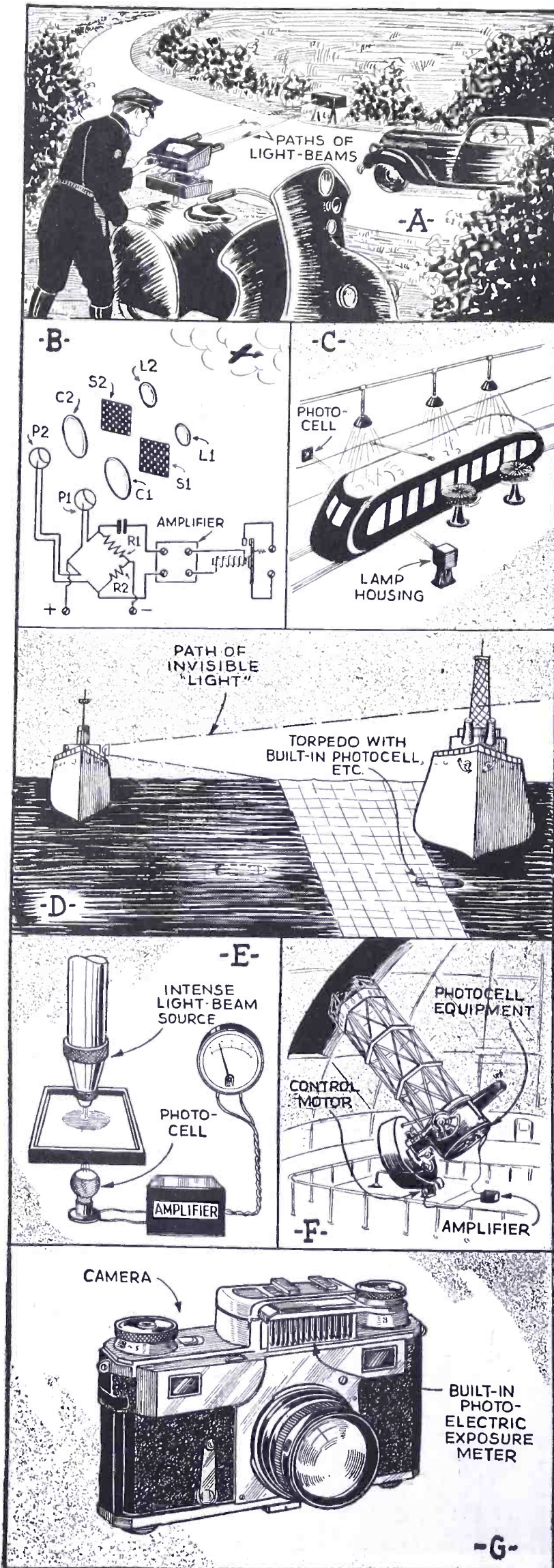



# SEE ALL-DO ALL

This article discusses some interesting applications of photocells. These include the following: auto-speed indicator, car counter, and airplane detector. Coffee-bean, cigarette paper, lethal-gas, and razorblade tests. Camera aperture, shutter, exposure, and focus control. And miscellaneous applications.

## WASHBURNE

on the other board will be opaque.

The light which each board permits to pass is focused by a second set of lenses onto 2 photocells that connect in bridge fashion to the input circuit of an A.F. amplifier; a relay is connected in the output circuit. This arrangement functions independently of cloud excursions across the field of vision.

A given point of light from an airplane falls, simultaneously, on an equivalent section of both checkerboards; but only 1 photocell is actuated since only board No. 1 can pass light through at that particular square. The point of light now moves along until the next pair of squares is reached; and only the square on board No. 2 will pass light through at this new position. And so the light darts through, actuating first one cell and then the other, alternately, and with sufficient rapidity to produce an A.C. voltage at the input of the receiver. (Fig. B)

### PHOTOELECTRIC TESTING UNITS

**Coffee Bean Tests.** Gourmets have traveled far for a real good cup of coffee. Today, though, extensive travel for the delight of a superlative brew of the bean is seldom necessary. Some idea of the importance of photoelectric equipment, used by Chase & Sanborn Coffee Co., for instance, to obtain a uniformly good product, in checking the exact roasting time of the coffee bean may be gained from the following interesting figures.

The particular flavor of coffee required in different localities or in different countries depends upon the proper treatment of the coffee bean, which must be roasted to a very definite color in order to obtain a particular flavor. Expert roasting operators are paid high wages for their ability to bring a load of coffee in the roaster to exactly the shade of a tested sample. But cloudy days or fatigue will result in errors. At best, a skilled operator cannot detect a variation of less than 15 seconds in roasting time as judged by the difference in color discernible to the naked eye. Photoelectric equipment, however, will easily detect roasting-time differences of 7½ seconds. The PE. apparatus also may be used to determine how much additional time is required to roast the coffee to a given degree; and for checking the output of several roasting plants to maintain uniform grade throughout. (Fig. M)

**"Electric Eye" Aids Milady's Smoke.** Photoelectric equipment is used by cigarette manufacturers to determine the opacity of cigarette paper. Chesterfield, for instance, uses the "electric eye" to determine, by variations in the amount of light reflected by the paper as it speeds along underneath an exciter lamp, the degree of uniformity and perfection of cigarette paper.

**The Electric Nose.** Mercury boilers, though efficient, occasionally leak and pollute the air with noxious mercury vapor. How to indicate the presence of the vapor was a problem until General Electric engineers conceived the idea of utilizing a sodium-type photocell to indicate the presence of a mercury-vapor shadow formed when factory air, filtered of all but its burden of mercury vapor, is made to pass through a beam of ultra-violet light from a mercury-vapor type of exciter lamp, as here illustrated. The "nose" will "smell" a mercury-bottle stopper held near the air intake of the device. The circuit is no longer new but it is reproduced here

(Continued on page 631)

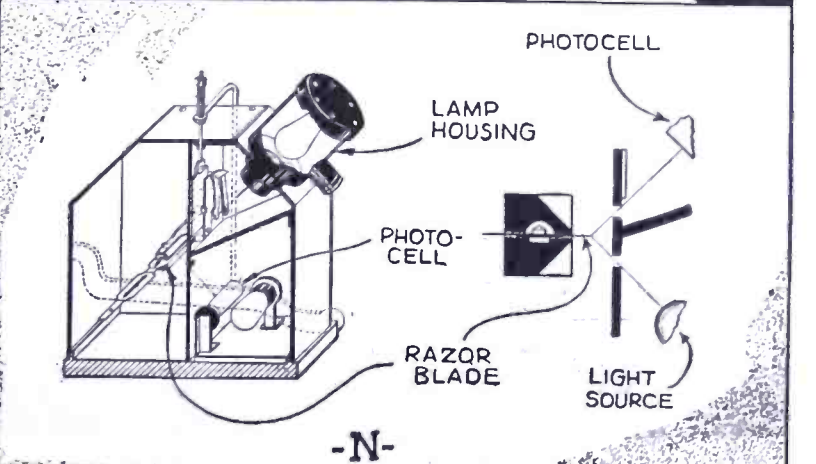
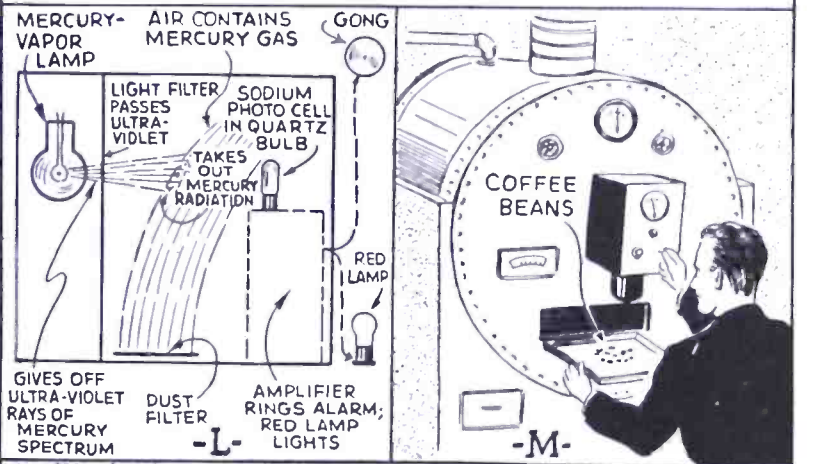
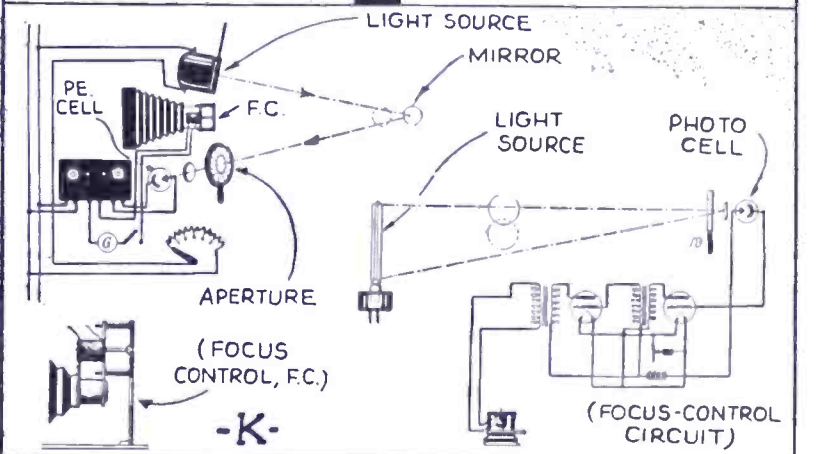
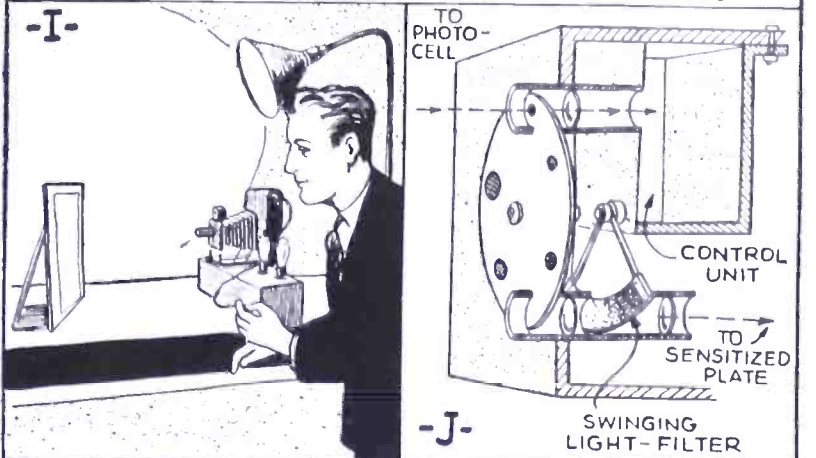
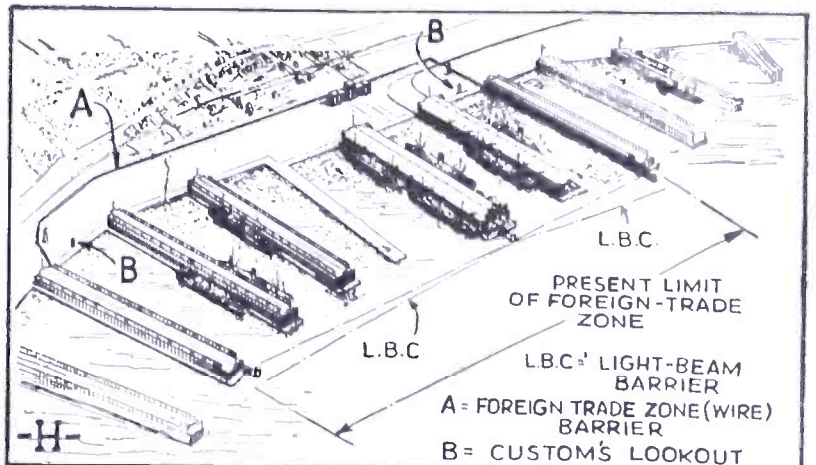



Fig. A. Each of 3 Corning color filters is interposed in the reflected-light beam and the resulting reading on a microammeter connected to a photocell affords an accurate means of color analysis and synthesis.

# "WHITE"

## IS A RAINBOW OF COLORS!

Details are given concerning a quantitative method of cataloging color by analyzing its primary components.

PART I ..... W. E. REYNOLDS AND A. R. HEXT

**W**HITE is simply "white" to most people, but to the *colorimeter* developed by the writers and here shown pictorially (Fig. A) and diagrammatically (Fig. 1), it is a veritable rainbow—a mixture of the proper percentages of the red, green and blue pri-

mary colors. The slightest variation in these percentages allows a multitude of variations or shades of white. Similarly, slight admixtures of either of the two primary colors to the remaining, third primary color results in a change of shade. By interposing a color filter between a photoelectric cell and a beam of light reflected from a surface under test a means is thereby afforded for making precise color analyses.

Thus Sir Isaac Newton's experiment of optically, by means of a prism (3-sided glass) interposed in a beam of sunlight, causing the white light of sunlight to be splayed out in all its glory of rainbow colors is now duplicated by electronic means. The result, instead of being observed by the human eye as in the former instance, is "seen" by the "electronic eye", and indicated on a meter, when color filters are interposed in the path of the white-light beam that impinges on the photoelectric cell.

(Continued on page 632)

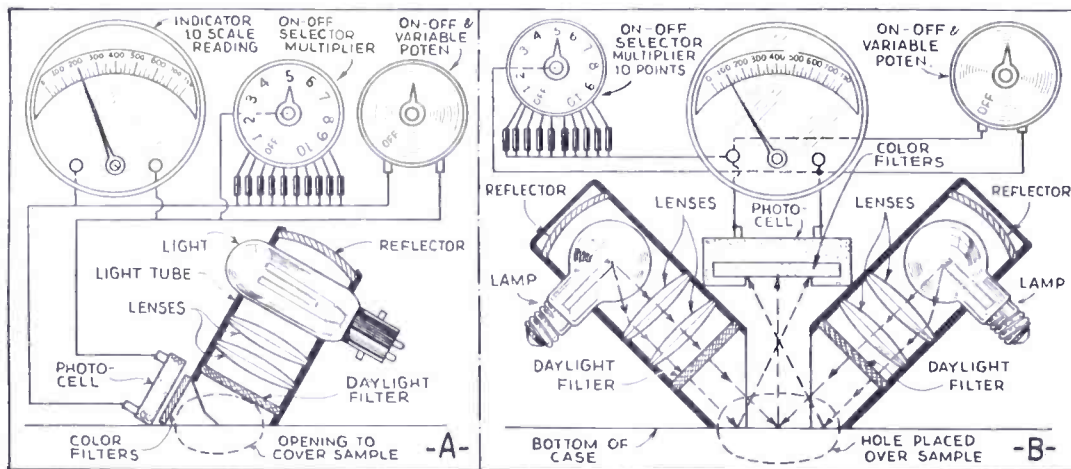

Fig. 1. At A, is shown a set-up for dull-surfaced, and at B, glossy-surfaced, materials.

# PHOTOTUBES AND PHOTOCELLS — WHEN TO USE THEM

Electronic practitioners will find much useful data in this article.

EARL D. WILSON

**A** PHOTOEMISSIVE device is a light-sensitive unit which functions by virtue of the emission of electrons from a surface into free space. A photovoltaic device is a light-sensitive unit which functions by virtue of the displacement of electrons from a semi-conducting medium into a contiguous conducting medium.

Purely for the sake of brevity, we shall call a photoemissive device a "phototube" and a photovoltaic device a "photocell".

We choose also to define (in this article) "light" to include radiant energy

in that portion of the spectrum commonly associated with photoelectric phenomena. (Inasmuch as the "electric eye" is susceptible to or otherwise will "see" what ordinarily would be referred to only as a "radiation".—Editor) Hence we may consistently refer to not only visible light, but also infrared "light," or ultraviolet "light." (Both the latter may be referred to as the so-called "black light"; but it is the latter that, in contrast with infrared radiations, due to its property of causing fluorescence in certain materials is commonly called "black light".—Editor)

### A SKIN-LIKE SURFACE

Fundamentally, there is no difference in the functioning of phototubes and photocells. In both types the energy of a "light quantum" (given amount of light) is imparted to an electron which rends itself from its orbit with an excess of kinetic energy to escape in the one case into free space or, in the other case, into a conductive medium.

To use a crude physiological simile, the surface of a phototube cathode might be likened to the raw dermis of animal skin, the electron corpulses bleeding

(Continued on page 638)

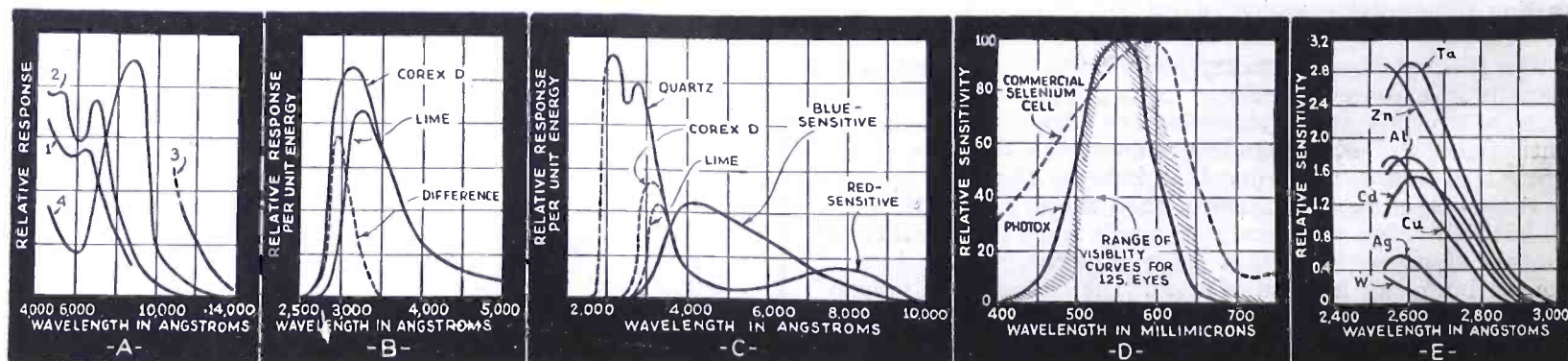

Fig. 1. Curves, when accompanied by adequate explanation, are an important adjunct to the electronic specialist.

# QUESTIONS AND ANSWERS ABOUT ELECTRONIC MUSIC

The recent series of articles on electronic musical instruments omitted the synthesizing system of Eremeeff which is here analyzed.

EDWARD KASSEL

**T**HE RECENT series of articles on the subject of electronic music which I wrote has aroused considerable interest, as letters from readers of *Radio-Craft* have indicated. The articles, covering as they did a very wide field of interest, were sketchy in parts, lacking somewhat in detail. This was necessary, because of the limited space available for the material.

Since there are probably many readers who have read the series of articles but have not taken advantage of my offer of supplying additional information on particular subjects where needed, some added data is presented here in answer to questions received. The letter, a representative one, is published, so that other readers will know just what questions were asked. The answers have been made as broad as possible, so that other readers will have their particular questions covered, as well.

## THE QUESTION—

I am building an electrical organ, using the phonic wheel and pick-up coil method of frequency generation, and wish to know the necessary data for determining the number of turns, size of wire, etc., for the coils. Would 3/16-in. magnet bar steel 2 1/4 ins. long be enough for the cores? The tone wheels are to be 3/32-in. thick, of soft sheet iron. Am using bevel gear drive; the generator frequency range is extensive.

The impedance of the coils I desire to be 4 ohms at the

respective frequencies, and am using a 15-ohm resistor between the coil and the key bus bars, similar to the Hammond.

In your earlier articles you mentioned you were going to give a stop arrangement and synthesizing system for this type of electronic organ, and the October issue stated that it was the concluding article, so apparently you have finished the series without so doing. You further state that you will answer questions concerning various questions we experimenters may have relative thereto.

The organ I am building is to have 2 manuals and a pedal clavier of 2 octaves, and have obtained an old square grand piano for its enclosure, intending to put the speaker, amplifiers and generators all therein.

PAUL J. PALMER

## THE ANSWER—

If you care to design magnet windings yourself, this problem can be solved as follows:

Impedance matching for the experimenter is simplified by sending several permanent windings and phonic wheel assembly to a transformer manufacturer who will check the impedances of different windings, beginning with 10 turns of No. 28 wire, together with the primary of an output transformer, which you must have.

It is practical to make the windings of the magnets with  
(Continued on page 633)

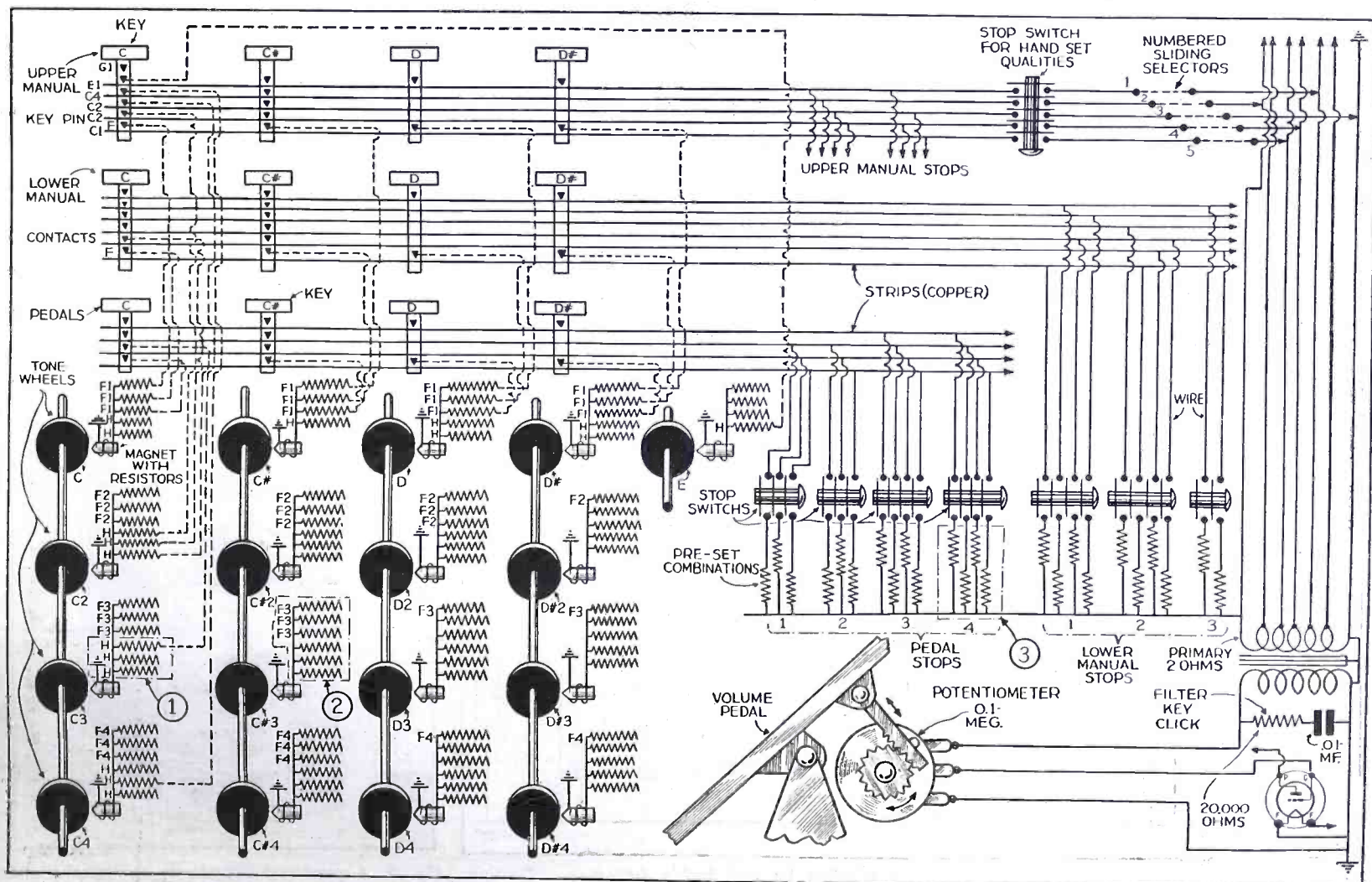

Fig. 1. A schematic presentation of the stop and synthesizing system developed by Eremeeff. This diagram has been requested by many experimenters.

# INTERNATIONAL RADIO REVIEW

RADIO-CRAFT receives hundreds of magazines from all parts of the world. Since the cost of subscribing to each of these would be prohibitive for most radio men, we have arranged with technical translators to prepare reviews for our readers.

## AN ACOUSTIC CORRECTOR

**R**EAIZING the difficulty of making a speaker cone or "piston" which will carry both very high and very low frequencies, a European engineer developed a diffuser to be placed in front of the speaker diaphragm to act as a tone corrector.

The tone corrector is mounted in front of the speaker (Fig. A) on a mounting which permits the distance between the corrector and the speaker diaphragm to be varied. The corrector consists of a flat metal "sound cell" of large diameter which is perforated and corrugated so that part of the sound passes directly to the hearer and part is reflected back to the speaker diaphragm. Thus by a combination of reflection and diffusion, which may be controlled by the listener, the tone range is extended. From *La Nature* (Paris).

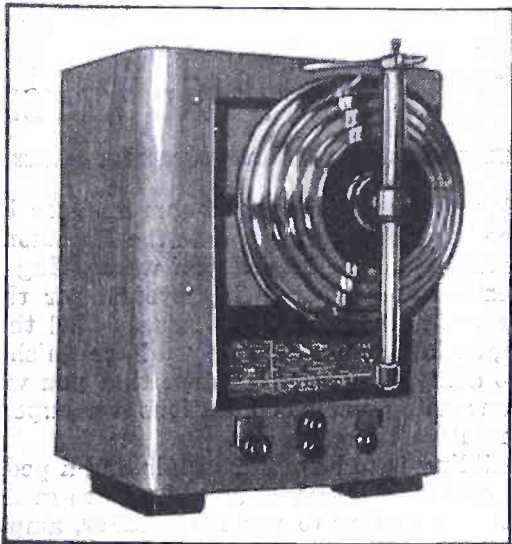

Fig. A. The Stereophone—acoustic corrector.

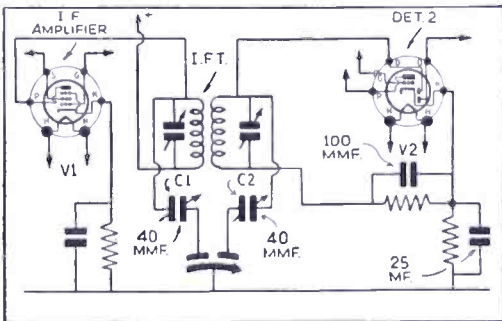

Fig. 1. Variable selectivity by detuning.

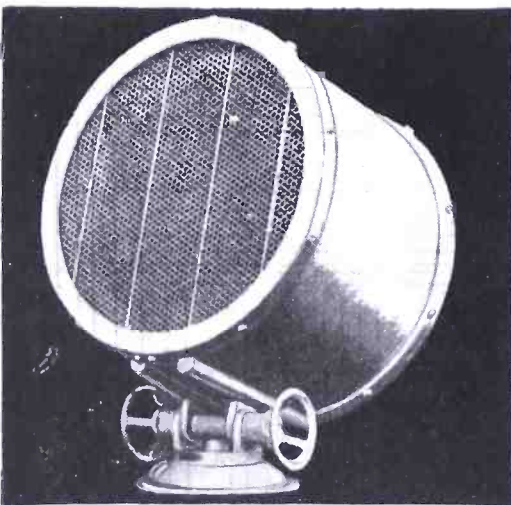

Fig. B. This is a speaker—not a searchlight.

## A VARIABLE-SELECTIVITY SCHEME

**A**S A MEANS of achieving variable selectivity in an existing superhet. receiver without the necessity of scrapping the I.F. transformers, an English experimenter devised the scheme shown in Fig. 1. This works on a system which differs to some extent from the other mechanical and electrical systems which have been previously developed. Instead of "loading" the coils in order to broaden their selectivity curve—or over-coupling them for the same purpose—they are detuned slightly so that their resonance curves do not exactly correspond. This produces the desired effect of widening the over-all selectivity curve for improving the fidelity of reception on local stations.

The 40-mmf. trimmers, C1 and C2, control the amount of detuning, while the split-stator variable condenser (having a capacity of about 50 mmf. for each section) provides the necessary control of sharp to broad selectivity. (Continued on page 614)

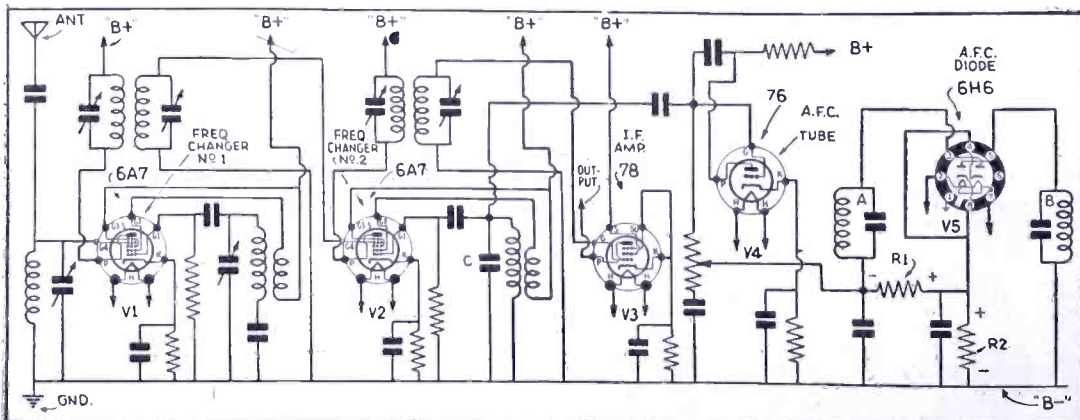

Fig. 2. Automatic frequency control is made more effective by this double frequency conversion scheme—from England.

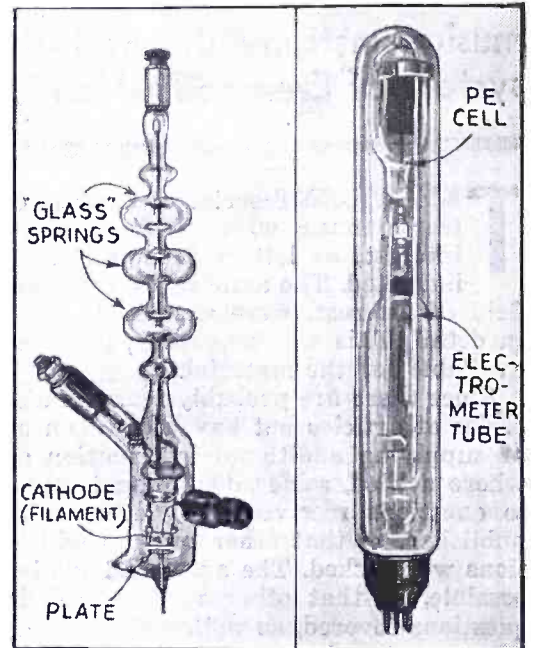

Fig. C. Two special tubes for the lab. A micro-wave diode and an electrometer-PE. cell.

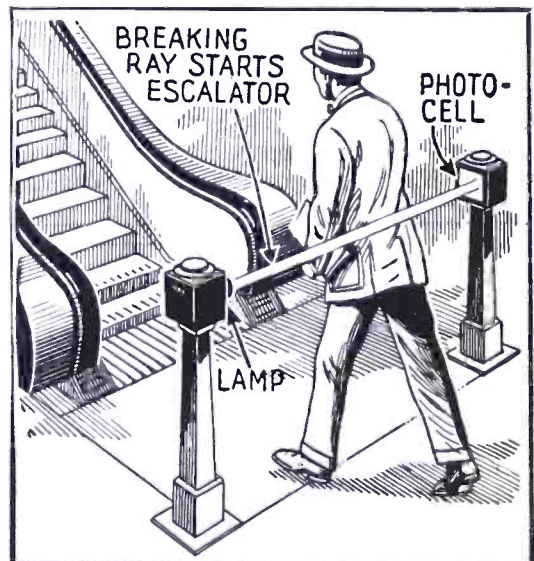

Fig. 3. The interruption of the infra-red light starts the escalator working!

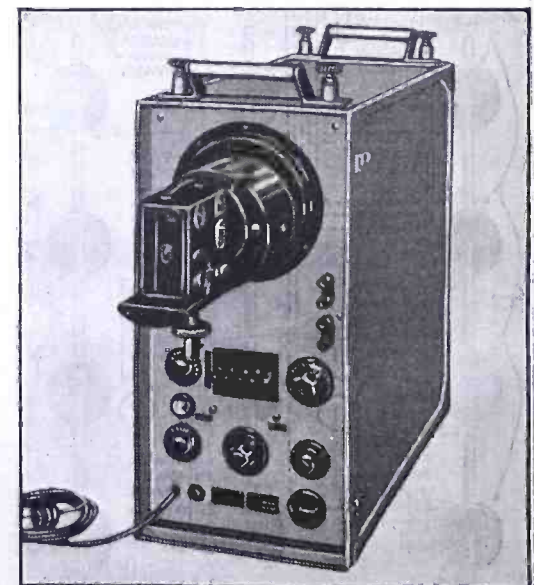

Fig. D. A combined cathode-ray oscilloscope and recording motion-picture camera.

# MAKE THE RADIO-CRAFT MIDGET OSCILLOSCOPE

This "complete" oscilloscope brings visual alignment within the reach of every Service Man! It uses a type 913 Cathode-ray tube,

## PART I

WITH THE advent of the new type 913 tube described in *Radio-Craft* for January 1937 there can be no further excuse for a Service Man not to build and use his own oscilloscope, for this tube makes the cost of such an instrument a minor factor indeed. It will certainly be a poorly-stocked service shop which has not on hand every item to construct this instrument, save possibly the power transformer and tubes.

Even if the shop owner already has a standard-size oscilloscope, the little instrument to be described makes a very handy gadget to carry on service calls, and in addition it will take no "Sampson" to carry this oscilloscope since it is smaller in size than most service oscillators! The total weight is but 9 lbs., a considerable difference from the usual oscilloscope which, while admittedly of excellent design and construction, certainly was not made to be carried by the already overburdened Service Man on his daily rounds.

Our little instrument has every feature of the full-size instruments as well as several which are not found on most. It can be used for virtually every possible test the Service Man or experimenter wishes to make.

### SWIVEL-MOUNTED C.-R. TUBE

A very novel feature is the fact that the 913 tube may be mounted in either of 2 positions, inside the instrument, or in the "trench mortar" on top. The socket in the latter is connected by a cable to the inside 913 tube socket so that the change-over is quickly accomplished. For portable use, the inside mounting is to be preferred since the addition of the "mortar" or turret makes the apparatus a little more un-

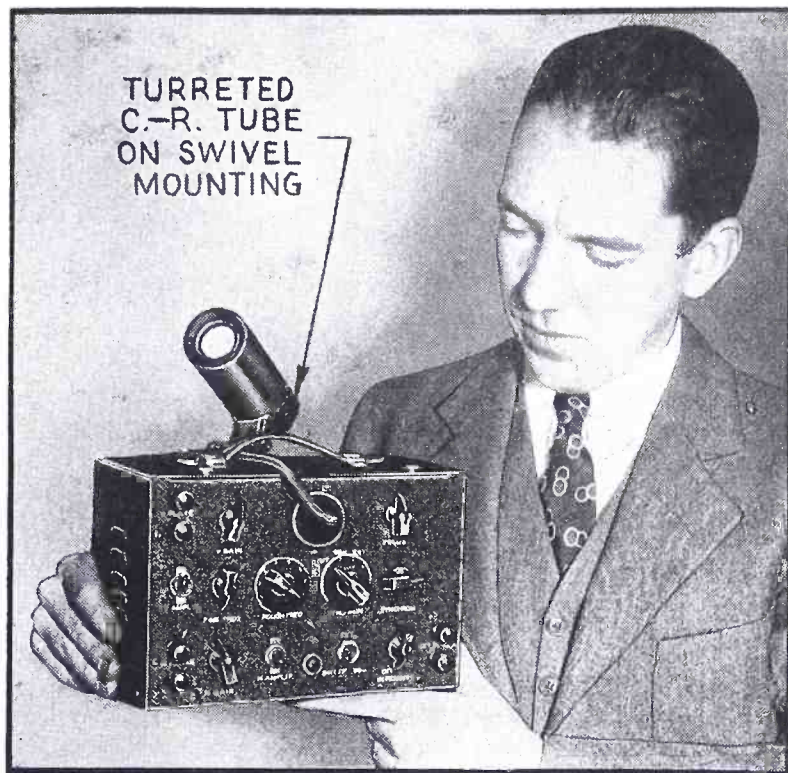

Fig. A. The complete unit with its "turret" tube support.

wieldly and unhandy to carry. For shop or laboratory use, however, the external mount is much handier. It can be adjusted to any position whatsoever so that if the technician is standing at the bench he does not need to stoop over to view the screen. The mounting is simply turned so that the tube points directly at him. In this connection it is quite possible and very practical to use a small magnifying glass fastened on the end of the "mortar" casing. A glass of about 1 3/4 in. dia. and of short focus, is excellent. In a pinch an ordinary reading glass will do very well but it must be held at from 4 to 6 inches from the screen of the 913 tube to give a worthwhile increase in image size.

### DESIGN FEATURES

The frequency of the sawtooth sweep oscillator is controlled in 8 rough steps, and in addition a fine control is provided.

Provision is made by proper switching, to use the horizontal amplitude control.

(Continued on page 618)

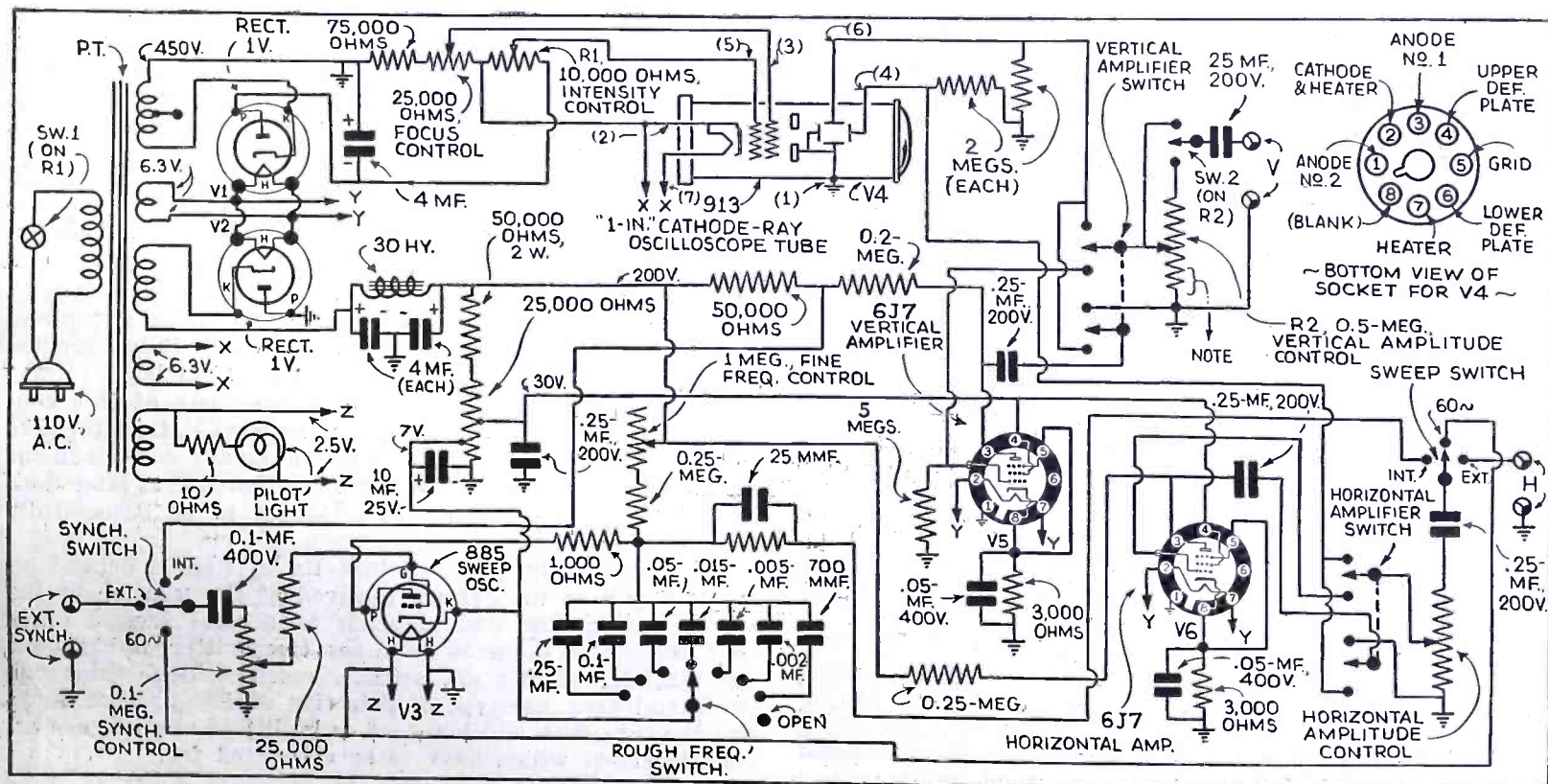

Fig. 1. Addendum: horizontal amplitude control, 1/2-meg.; return control-grid of V6 to ground through 5 megs.; the 25 mfm. condenser shunts a 1/2-meg. resistor.

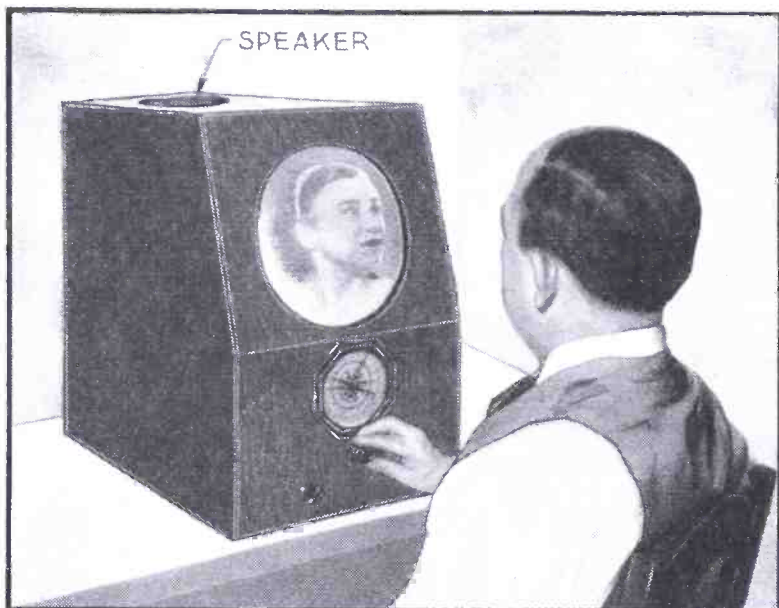

Fig. J. Here is the cathode-ray receiver in its complete form—in operation.

**A** TELEVISION receiver in its construction embraces several factors which vary widely from those encountered in building the usual sound radio receiver. One of these variations is in the detector or demodulator. On this detail of the receiver design, more than any other, depends the definition of the images received. The flat characteristic, covering the frequency range passed by the I.F. amplifier, is one of the most essential elements of the receiver.

For this reason, since the original half-wave diode circuit was printed, in Fig. 1, some experimental work has been done by the *Radio-Craft* laboratory and several improved circuits are shown in Fig. 7, which may be used to replace the original one, providing improved image definition. The first, shown at A, is a change from half-wave to full-wave diode rectification. This change necessitates center-tapping the secondary of I.F.T.3, which may at first thought be a difficult task, but actually it is not very hard. The coil is removed from the set and the shield can taken off. This exposes the 2 coils on their "iron" core with the air-trimmers at the upper end. The number of layers of wire on the secondary is then counted (it will be found to be 9 layers) and the "end" wire of the center layer is pulled out a little from the winding. This permits the insulation to be scraped off and the enamel to be removed with alcohol. A wire is then carefully soldered to the exposed tap and a lead carried out through the fibre centering strip. (While this wire may

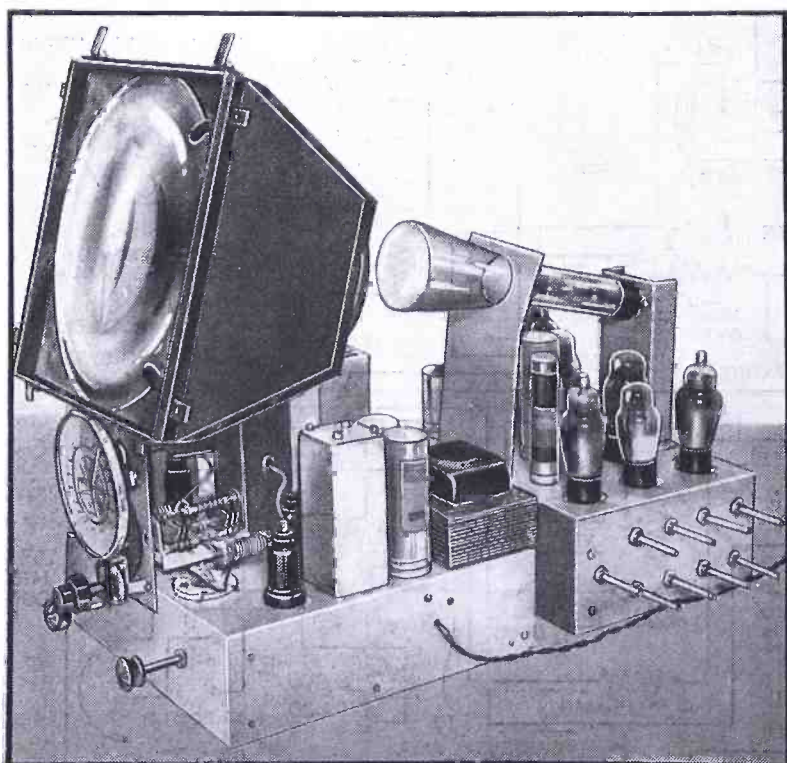

Fig. K. Here we see the receiver with the cabinet removed. The lens system is used to enlarge the images from 2½ ins. to about 8 ins.

# HOW TO MAKE THE TELEVISION

In this, Part IV, the concluding data for making the RADIO-CRAFT Television Receiver, built under the direction of C. W. Palmer, are given. Review the complete series of articles before starting the actual construction of the receiver.

## PART IV

not be at the exact center of the winding, it has been found experimentally that the difference in I.F. voltage is so slight it may be entirely neglected.)

Now, as for the difference between the circuits in Fig. 7A and B. That at A gives much better definition than the original half-wave circuit, and the reduction in rectified voltage compared to the circuit in Fig. 7B is not so pronounced. The circuit of Fig. 7B, however gives much better definition than either of the other two detectors, though the signals are attenuated more.

For those builders who are but a few miles from the television station which is to be picked up, the circuit of Fig. 7B is best. The 30-V. positive tap can be obtained by shunting a variable voltage divider of about 50,000 ohms across the "B" supply and connecting the tap to the detector. For those builders who do not pick up a very strong carrier from the television station, the circuit of Fig. 7A is preferred, while with a very weak carrier, the original half-wave circuit is best, since it provides a stronger rectified signal than the other two.

### SOUND CHANNEL ALIGNMENT

A question has arisen by several builders of the set regarding the alignment of the sound channel, described in Part III of this series. Unfortunately, some descriptive matter concerning this I.F. amplifier was inadvertently omitted, which has caused the questions. The I.F. transformers used in the sound channel do not tune to a frequency of 5,350 kc. and since they provide a much higher gain than the air-core type, they were used, but instead of tuning them to 5,350 kc. they were tuned to the 2nd-harmonic of this frequency or 2,675 kc. This does not make use of the coils at their peak efficiency, but plenty of gain was obtained in the experimental model and because of certain desirable characteristics of these "iron-core" transformers, they were decided upon.

Since the description, last month, the manufacturer of these coils has introduced a new type of I.F. transformer (having the iron cores and air-trimmers) which tunes to 5,350 kc. Those who prefer to obtain these transformers will find that the sound channel will have more gain than with the type previously specified. There are no changes required, other than inserting the new coils in place of those specified in the circuit, Fig. 4. \*(Footnote, at end of article.)

Another "loose end" in the previous parts of this constructive series is the matter of loading the I.F. transformers of the video channel to provide the necessary wide band for television reception. In Part I, we mentioned that later data would be given to permit this loading to be successfully accomplished.

The actual values of resistors Rx in Fig. 1, depend on the strength of the carrier received at the location of the receiver. And since this depends on several factors other than the actual distance from the transmitter, it has been left until the signals are actually received. Such things as the aerial used, the type of detection scheme decided upon, and the care with which the set is built and aligned, are all considerations which have to be accounted for.

The best way to ascertain the optimum value of these

# RADIO-CRAFT—1937 RECEIVER

Lenox R. Lohr, President of RCA, said, last month, upon resumption of transmissions of the Empire State television transmitter using 441 lines: "Pictures of 441-line definition are much clearer than those of 343 lines—the definition employed in previous tests from the Empire State. Another significant advance has been made in our work of television development. As we proceed in this fascinating adventure of bringing radio sight to distant eyes, it is encouraging to be able to report this substantial progress."

resistors is to actually get the set working and then try different values across the coils until the best all around results are obtained. A value of 50,000 ohms is a good one to start with—working down until the gain of the set is too low to give good definition. A certain value will be found at which the definition—determined by band width and amplifier gain—is best.

There is another point (which will be of interest to experimenters) about the I.F. adjustment. The I.F. coils are supplied with optimum coupling between primary and secondary—for the reception of "sound" broadcasting. Now, if the spacing between the windings is reduced to introduce "over coupling" the selectivity of the I.F. amplifier will be lowered, without introducing loading resistors (Rx) across the windings. By this method, the resistance value of the loading resistors can be increased so that the actual gain of the I.F. amplifier will be higher at the required I.F. band width. By experimenting with the coupling, the correct relation of coupling and loading can be determined. An oscilloscope and wide-frequency wobbler will be helpful in this work. Remember that it will be necessary to re-tune the I.F. coils if the coupling is varied—and this should be done without the loading resistors, Rx, in place.

## THE AERIAL

The next point to consider is the subject of aerials. The strength of the carrier signal picked up on micro-waves

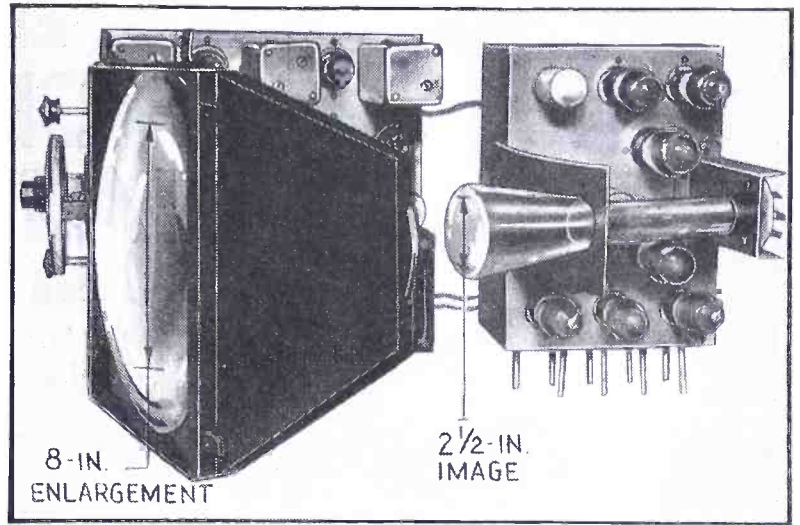

Fig. 1. The top view of the set showing comparative image size.

depends greatly on the type of aerial—its location and the care with which it is erected.

In Fig. 7, several types of tuned aerials are shown. See details C to F. The units shown in Fig. 7C, D, and E, consist of single rods of copper or other suitable low-resistance material which should be arranged to "telescope" so that the actual length can be varied to suit the frequency of the transmitter being received. The unit at C has 2 wires soldered to the central portion of the rod, about 28 ins. apart. These wires are carried down with ceramic spacers to keep them about 2 ins. apart and a coupling coil of about 2 or 3 turns of heavy wire wound to a diameter of about  $\frac{3}{8}$ -in. is connected to these two wires and coupled to the grid coil of the 1st-detector, V1. The rod is mounted vertically and must be well-insulated from all conducting bodies.

The next aerial, Fig. 7D, consists of the same type of telescoping rod, but a single lead-in wire is fastened to the top end of the rod and run down to the receiver at an angle as near to 45 deg. as possible. This aerial is a favorite with many "hams" and was found to supply the best "wham" in the original set-up. The rod is adjusted to resonance with the station as a half-wave resonator.

Next is the vertical "dipole" (Fig. 7E) with the rod split into 2 parts, each tuned to  $\frac{1}{4}$ -wave. This is made with 2 lead-in wires spaced about 2 ins. apart in the same way as that shown for detail C. The last aerial shown is the horizontal dipole which is like the vertical unit, though the

(Continued on page 624)

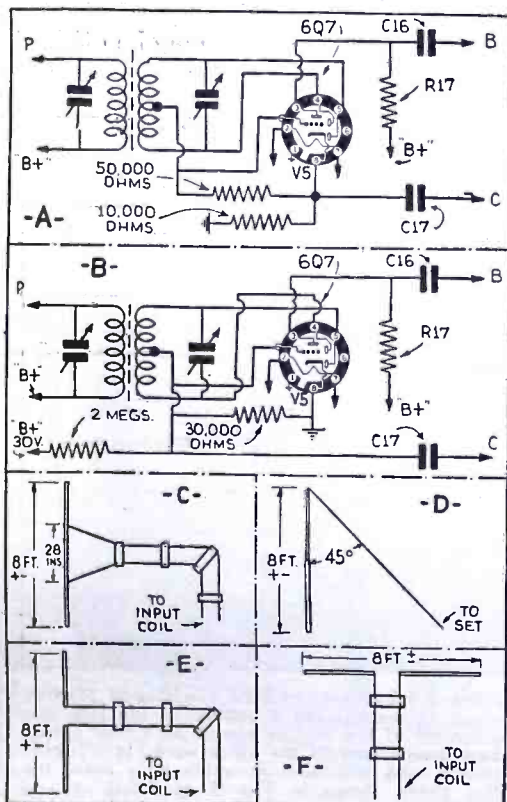

Fig. 7. Detector changes and aerials.

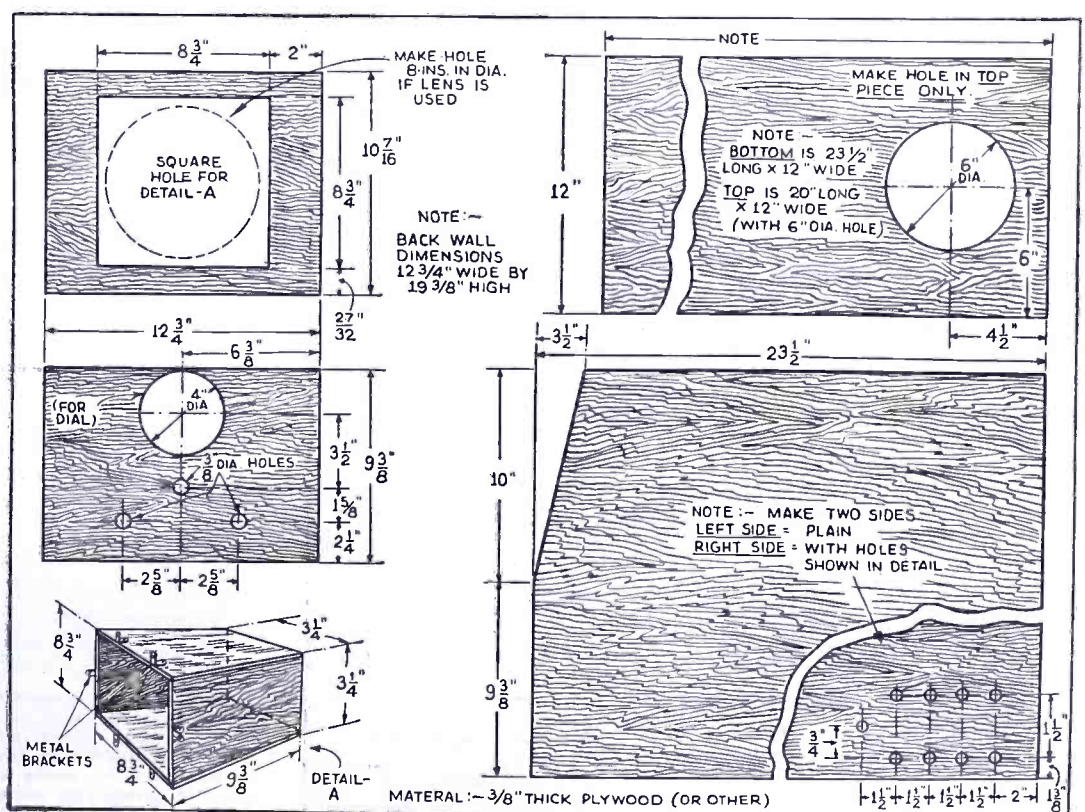

Fig. 8. Details for making the cabinet and "viewing funnel" if a lens is not used.

# MODERN SHORT-WAVE DIATHERMY

Experienced radio men can build this modern 250-W. (R.F. output), 16-meter diathermy machine—designed for the use of doctors. Interference problems are discussed.

LEON C. BUNKIN.....PART III

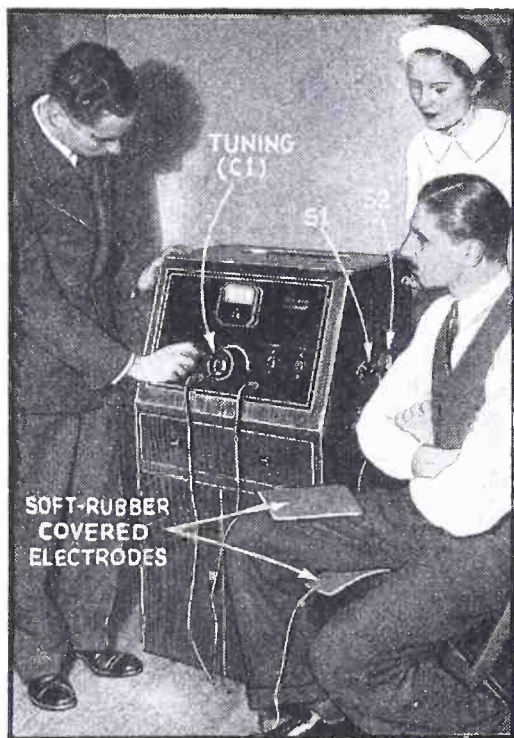

Fig. F. In appearance the unit is "commercial."

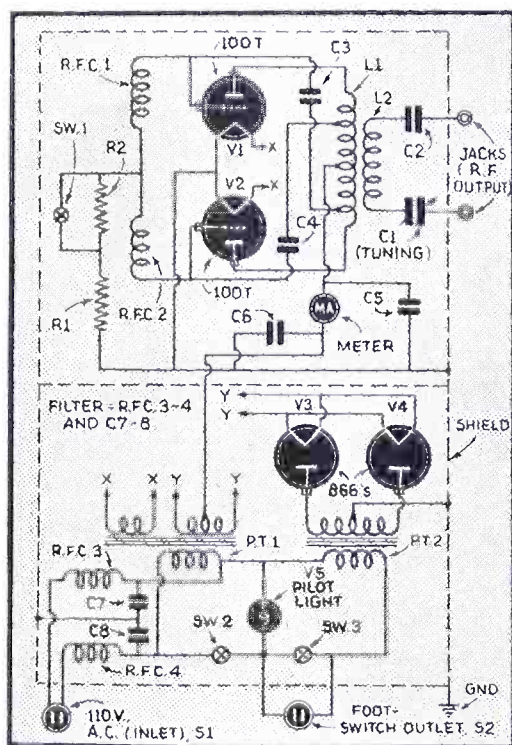

Fig. 3. The schematic circuit of the device described. Note the interference filter.

**T**HE NECESSARY requirements for the design of a short-wave diathermy machine can be realized from the preceding instalments of this article. Preparatory to the actual construction of a machine that will function satisfactorily we must bear in mind the following basic essentials:

- (1) The circuit used must have the ability to perform in a stable manner, and should display no tendency to go out of oscillation under varying load conditions.
- (2) Full-wave rectification with the addition of some ripple filter must be incorporated.
- (3) The design of the circuit must be such that complete protection is afforded both the physician and the patient against possible electrical burns and shocks (even a slight shock might prove fatal to a person whose heart is weak).

With these factors as a basis, the author, W2GF, in collaboration with Leon I. Sprung, W2ACG, "set to work."

## CIRCUIT CONSIDERATIONS

Considerable experimentation with different oscillator circuits finally led to the choice of the Hartley oscillator in a push-pull version of the circuit. It acted most stably, maintaining constant oscillation regardless of load.

The choice of tubes is an important consideration. They must be of rugged design, and have an output capability

of at least 250 W. For this reason a pair as specified in the List of Parts was chosen.

It would have been "penny wise and pound foolish" to use low-grade parts; hence, to ensure perfect performance and requisite durability, only the best of standard parts were tolerated.

Reference to the circuit diagram will show clearly the salient points to be discussed.

For ordinary S-W. diathermy the regular control-grid bias of 10,000 ohms, R1, is used. For high-frequency cutting, etc., however, this bias was increased to 35,000 ohms by the addition of a 25,000-ohm resistor, R2, with a switch, Sw.1, across it to cut R1 in or out of the circuit. The power supply delivers about 1,500 V.; tubes V1, V2, therefore (so as not to exceed the dissipation rating of the tubes when the bias is 10,000 ohms), should not be run at more than 250 ma.

An examination of the diagram will show the power switching arrangement employed. The plate voltage can not be applied until the filament voltage has first been switched on. The precaution of allowing the filaments to heat up about 15 seconds before throwing on the plate voltage should be observed to protect the life of the tubes. (If desired a 15-sec. time-delay switch may be utilized to accomplish this result.)

The prospective builder may follow  
(Continued on page 620)

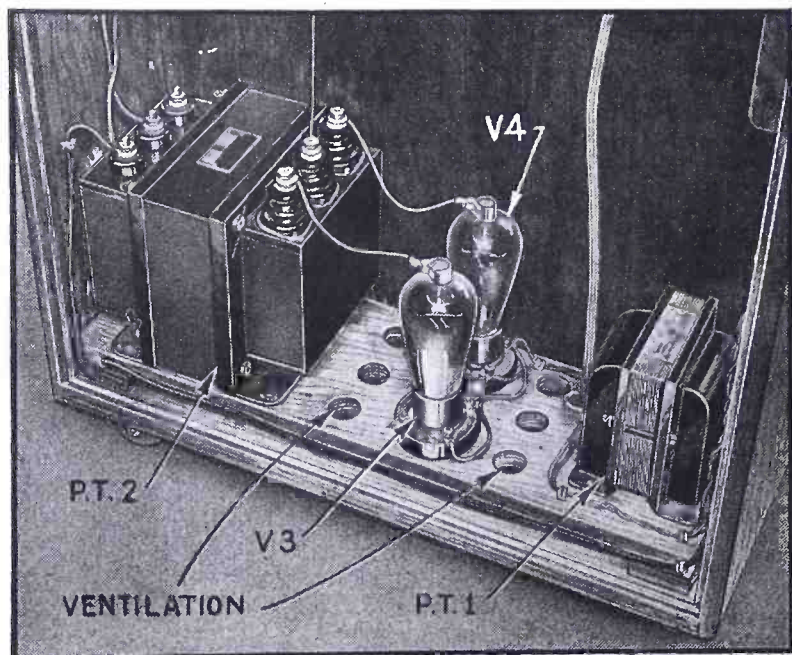

Fig. G. The power supply equipment on the lower shelf.

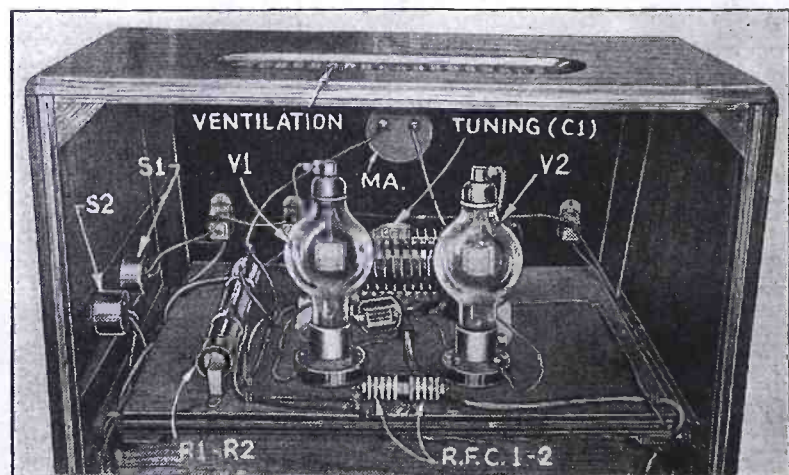

Fig. H. The oscillator itself. The 2 tubes are used in a push-pull Hartley circuit on a wavelength of about 16 meters. The 2 outlets on the left side of the cabinet permit remote control of the unit by means of a foot switch when it is desired to keep both hands free to do other work. In addition to shielding the entire equipment, and the room in which it is used, the suitable power-line noise filter choke shown in Fig. 3 as R.F.C.3-4 and C7-8 is necessary. It was removed before the power supply was photographed in order to clarify illustration, Fig. G, of this portion of the equipment.



This department brings to you each month the newest developments in electronic, radio and public-address equipment. Aggressive technicians use this department to keep posted on the newer and better ways of doing things.

# THE LATEST RADIO EQUIPMENT



Combined phono. and P.A. unit. (1310)

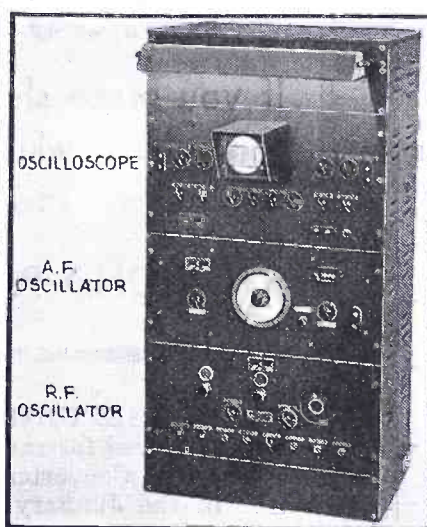

Complete service lab. (1313)



Dial your favorite radio station. (1316)

## PHONO.-P.A. UNIT (1310) (Radolek Company)

**P**UBLIC-ADDRESS specialists have long wanted a compact unit with the capabilities of the 20 W. device here illustrated. It operates on either 6 V. D.C. (12 A.), or 110 V. A.C. Has gain sufficient for crystal microphone unit; tone control; removable remote control head equipped with 2 volume controls; adjustable mounting legs.

## SMALL VOLT-OHM-MILLIAMMETER (1311)

(The Readrite Meter Works)

**T**HE feature of this instrument is its range—in a metal cabinet that measures only 5 7/8 x 7 7/8 x 4 1/8 ins. deep. Ranges: 10-50-250-500-1,000 A.C. and D.C. volts at 1,000 ohms-per-volt (D.C. accuracy 2 per cent; A.C., 6 per cent); 1-10-50-250 D.C. ma.; 0-300 low ohms; high

ohms to 0.25-meg. at 1 1/2 V. (and higher, if external battery is used).

## MULTIPLE CONDENSER (1312)

**O**NLY individual sections of this condenser unit need be replaced in the event of failure.

## TEST EQUIPMENT GOES RACK AND PANEL (1313)

(Clough-Brengle Co.)

**T**HE workbench overflowing with test equipment is the earmark of an outmoded service shop. One modern service lab. design incorporates its test equipment in a bay of rack-and-panel type. Several panel combinations are available, and the entire equipment is available on a time payment basis.

## PORTABLE 20-W. AMPLIFIER (1314)

**T**HE input arrangement of this compact, light-weight amplifier permits using 2 microphones, or 1 microphone and phonograph, or 2 phonographs. Output is tapped at 3-6-250-500 ohms.

## DOUBLE-ENDED SOLDERING IRON (1315)

(Supreme Instruments Corp.)

**V**ETERAN service engineers developed this new soldering tool. Available in single heat at 125 W.; and triple heat—75-125-200 W.—OK for general light work, medium work and quick-heating or heavy work.

Tips, extensible to 4 ins., are available in several shapes; tip-angle is adjustable over wide range.

## MANTEL SET WITH FINGER TUNING (1316)

**F**AVORED-station call lettered are pasted into circular windows on the dial of this 5-tube A.C. superhet. The desired "call" is swung to a reference point and then slightly rocked for more accurate tuning.

## POWER OUTPUT TUBE TESTER (1317)

(The Triplett Electrical Instrument Co.)

**T**HIS new instrument tests all tubes under actual operating voltages. It includes a test of rectifier tubes and separate diodes; neon test for shorts and leakage.

## SMALLER ELECTROLYTIC (1318)

(Cornell-Dubilier Corp.)

**C**OLLOQUIAL but apt is the trade name "dwarf midget" used to designate this new dry electrolytic. Compare the triple 8 mf. for instance with preceding types of 450 V. D.C. (working) dry electrolytic condensers. Note individual leads.

## VERSATILE SERVICE OSCILLATOR (1319)

(Triumph Manufacturing Co.)

**M**OST unfortunately space limitations preclude listing here (Continued on page 625)

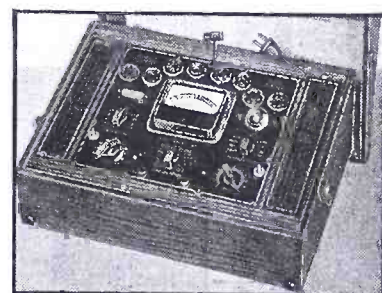

Working-voltage tube tester. (1317)

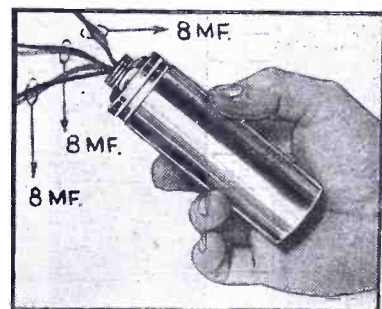

Small-size 450 V. D.C. electrolytic. (1318)

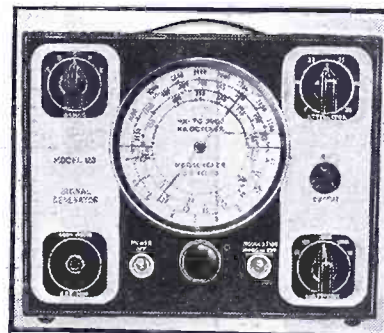

A 30-feature service oscillator. (1319)

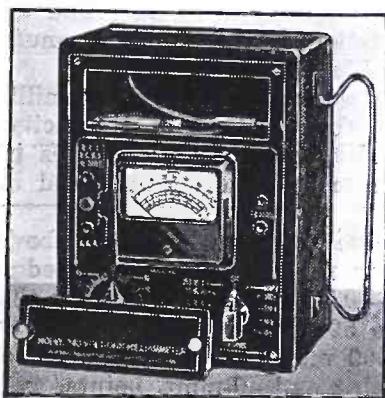

Multimeters are getting smaller. (1311)

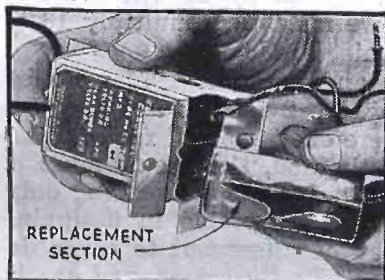

Remove only one section. (1312)



A small-size P.A. unit. (1314)

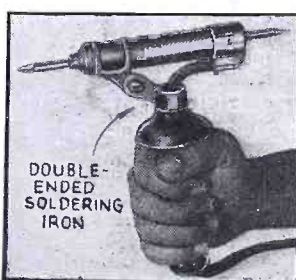

DOUBLE-ENDED SOLDERING IRON

A 2-ended tool. (1315)

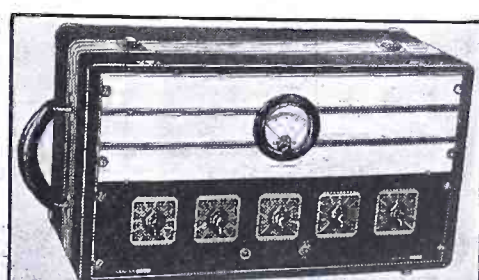

A P.A. unit designed for boats. (1320)

Name and address of any manufacturer will be sent on receipt of self-addressed, stamped envelope. Kindly give (number) in above description of device.

# SHORT-WAVE COILS IN A JIFFY

## —IF YOU USE THIS CHART!

If you make short-wave sets or converters, this chart will greatly simplify your coil problems. How do you like it?

RAYMOND P. ADAMS

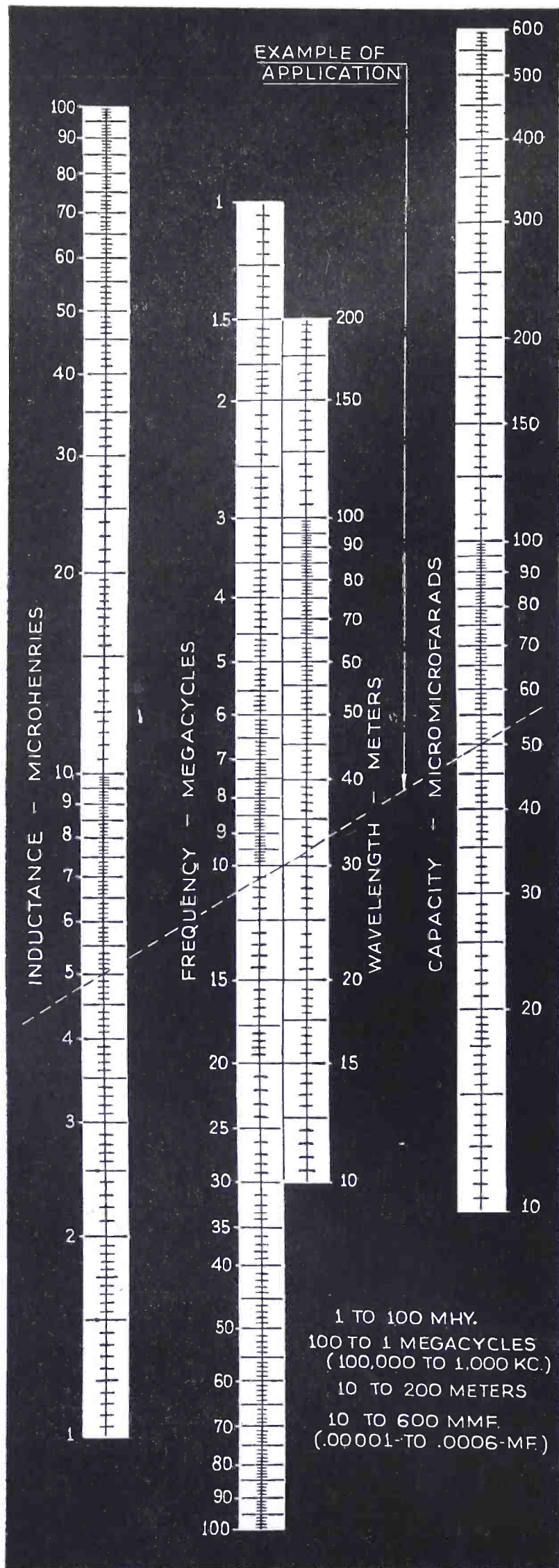

Fig. 1. A straight-edge is placed across the scales.

THE USEFUL chart shown in Fig. 1 at the left has been prepared for radio men interested in building the "Simplified Converter for Short-Wave Beginners," described in the January and February 1937 issues of *Radio-Craft*. It can also be used for almost any desired short-wave coil calculations in receiver and converter construction. Its utility range is confined, therefore, to the frequencies covered in practical short-wave receiver service. Using the chart, the designer may directly and easily find an unknown with 2 known factors, providing, of course, the 2 knowns may be found on the chart scales, and the unknown lies in the straight-line-relation range.

With the 2 knowns spotted, a straight line is drawn between them and the unknown found where the line crosses the 3rd scale, either in traveling between the points or in extension.

For example, suppose we have a coil of known 5 microhenries inductance and we wish to know the frequency to which this coil will tune with a capacity of 50 mmf. (or .00005-mf.). We check these 2 figures on the capacity and inductance scales, draw a straight line between them, and find that we cross the frequency scale at 10 megacycles (10,000 kc. or 30 meters). Or, if we have a variable condenser which we wish to use in a tuned circuit and which at a value of 50 mmf. is to "hit" 30 meters; we draw a straight line between the known frequency and capacity scales, from known point to known point, and extend it to cross the 3rd scale for inductance at 5 microhenries. The coil required should have this inductance; to be found by trial and error, and the application of the simple formula found in the text of the Short-Wave Converter article.

The inductance figures are in *microhenries* and *not* millihenries. The frequency figures, for the sake of simplicity, are given in terms of *megacycles*; the capacity figures in terms of *micromicrofarads*. These same terms are used in the inductance formula.

The chart may be used to give readings below or above the scale ranges by dividing or multiplying straight-edge figures by 10, or multiples of 10. If we wish to know the inductance required to tune to 500 meters or 600 kc., for instance, with a capacity of 400 mmf., we simply draw a straight line between the 500-meter and 400-mmf. points, and extend the line to cross the inductance scale. We find the inductance reading to be approximately 16. As we divided both capacity and wavelength figures by 10 (in order to use our limited-range chart), we must now multiply 16 by 10 in order to get the true required inductance.

The chart is fairly accurate and for almost all practical purposes may be relied upon where 2 factors are known—one desired, one measured. Where one "known" factor (particularly capacity) must be estimated, the result must of necessity be considered a near or approximate reading only. Approximations, however, will be acceptable in designing coils for the converter, accuracy of alignment to cover desired frequencies being a matter of adjustment, and check-up against the carriers of stations known to be crystal-controlled, with coils built and wired into the circuit.

# DIRECT-COUPLING IN A 30-W. BEAM-TUBE AMPLIFIER!

This Part continues the consideration of the unusual power supply in the amplifier and covers the phase-inverting scheme.

A. C. SHANEY ..... PART II

**T**O CONTINUE the discussion of the rectifier system used in the direct-coupled amplifier, where we left off in Part I, last month, we find that if a uniform load resistance is applied across the rectifier output, the potential difference between the center of the load and the center-tap of the coil is zero. If these two points be joined and the circuit redrawn, it will appear as in Fig. 2A.

The insertion of a choke in each leg of the rectifier output and appropriate filter condenser produces the stabilized 2-phase bridge rectifier as utilized in Fig. 2B and heretofore unused in P.A. amplifiers.

The advantages of this rectifier system are manifold. In the first place, the pivot of the circuit (the voltage at the mid-point of the load) is always kept at a constant potential and detrimental trigger action is avoided. Secondly, 600

V. output is available from a 650-V. center-tapped transformer. (Another glance at Fig. 2A will disclose the presence of a full-wave voltage doubler in our synthesized rectifier.) Thirdly, hum potentials are almost completely cancelled out by virtue of identical choke coils and bypass condensers in each of the output legs of the rectifier, so that all hum potentials picked off each leg are equal but opposite in phase and are cancelled when fed to the zero-potential mid-point of the bridge rectifier.

Because of the fact that mercury-vapor tubes (type 83) are not available with isolated filaments for each half of the tube, 2 tubes must be used for rectifying one of the voltage phases while the 3rd rectifier is used in the conventional manner. In order to keep the regulation of each side perfectly balanced, only one plate of V1 and V2

(Continued on page 622)

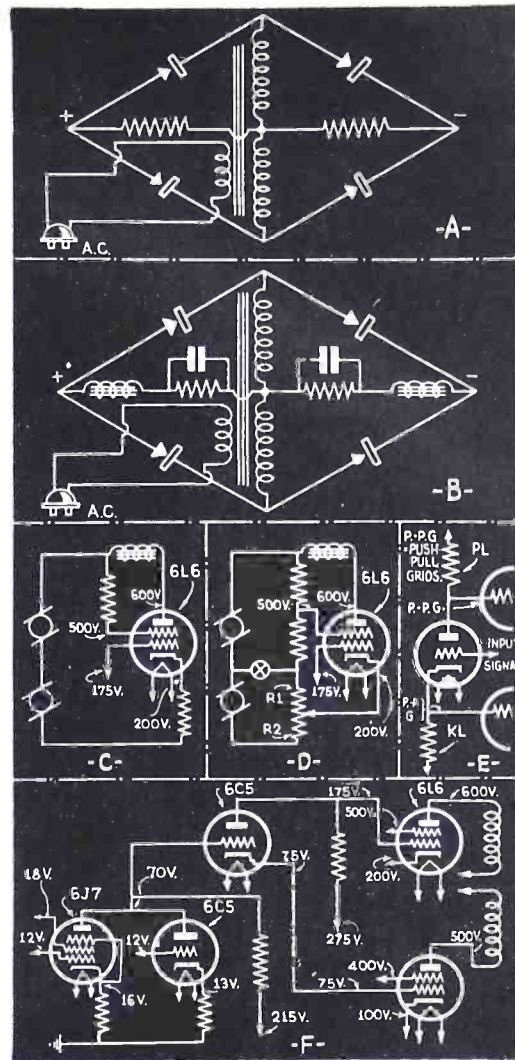

Fig. 2. Rectifier details and voltage distribution.

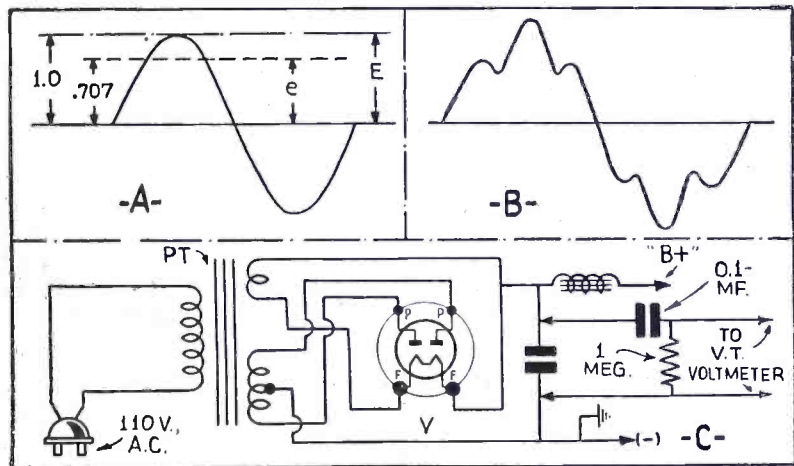

Fig. 3. Sine and non-sinusoidal voltages—and peak measuring circuit.

## HOW TO USE V.-T. VOLTMETERS IN RADIO AND P.A. SERVICING

The measurement of non-sinusoidal voltages necessitates a "peak voltage" meter.

PART II—PEAK MEASUREMENTS  
KENDALL CLOUGH .....

**T**HE LOWER scale of the instrument illustrated in Part I is calibrated directly in *peak volts* over 2 scales—0-10 and 0-100 V., with an automatically-operated multiplier device.

The sinusoidal voltage graphed in Fig. 3A has a peak voltage of value *E*, but an effective or root-mean-square (r.m.s.) value of *e*. In this, since it is a pure sine wave under consideration, the value of *E* is equal to 1.41 times *e*. The ordinary voltmeter reads r.m.s., and when the voltage is known to be sinusoidal in shape, the peak value may be calculated.

However in circuits employed for radio sets and amplifiers, the voltage wave frequently is other than sinusoidal, and an instrument capable of measuring the actual peak value is needed if

one is to know the actual circuit conditions in determining needed ratings of condensers, etc. A typical measurement of this type is described in the following paragraphs.

Figure 3C shows the manner in which the instrument might be set up for measuring the peak A.C. voltage across the first filter condenser in a power supply circuit. A blocking condenser of 0.1-mf. capacity and voltage rating sufficient to withstand the potential, and a 1-meg. resistor are connected across the instrument binding posts marked "PEAK". In this manner the voltage reading obtained will be the value of the peak A.C. potential or ripple coming through the rectifier tube of the power supply.

Inasmuch as this ripple voltage may

have unequal positive and negative peaks, the test leads should be reversed and the highest voltage reading of the two trials be used for calculations. By adding this peak A.C. voltage to the D.C. potential being developed in the circuit, it is possible to determine the peak voltage to which the condensers in the power supply are called upon to withstand.

A similar measurement may be made at the output of the power supply, reversing the test leads to secure the value of both positive and negative peaks. The percentage of ripple can then be computed by dividing the average value of these two peaks with the D.C. voltage output. It may be desirable to repeat these tests under various conditions of

(Continued on page 615)

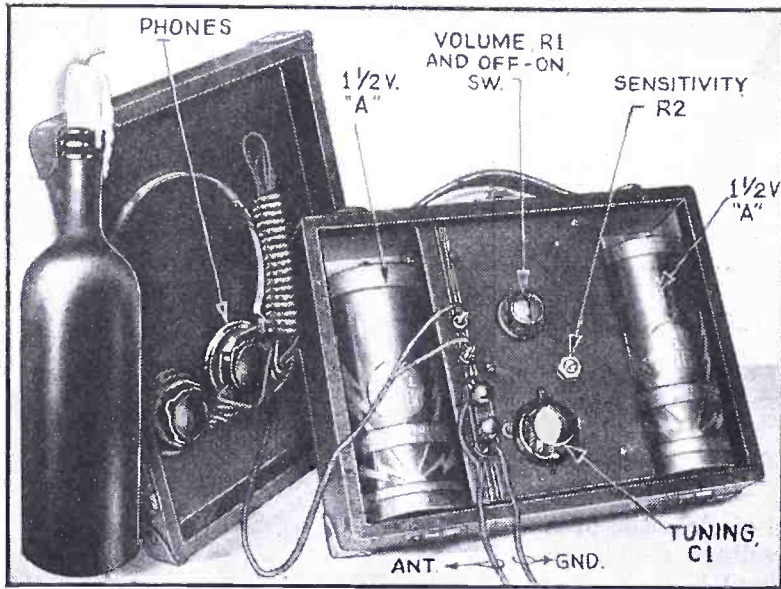

Fig. A. A battery-operated radio set for emergency operation.

# BUILD THIS "2-IN-1" EMERGENCY RADIO SET

Floods, hurricanes, earthquakes, fires—these uncontrollable forces of Nature often disable established methods of communication, and, therein lies the merit of this construction article. A 1-tube battery-operated set for receiving emergency radio broadcasts is described.

N. H. LESSEM

**F**EW people realize the important role the innocent-looking home broadcast set can be made to play in times of stress. Since radio is usually the last medium of communication to be affected by such unfortunate catastrophes as floods, earthquakes, blizzards, and the like, it is being depended upon, more and more, to coordinate the work of rescue and relief agencies. At this very writing, as unprecedented flood waters rage through the Ohio and Mississippi Valleys, local broadcast stations (operating with emergency heavy-duty batteries) are cooperating with boat crews equipped with portable battery sets in directing rescue work and acting in general as a clearing house for all important messages. In the stricken areas people fortunate enough to own battery-operated sets are in a position to be immediately warned of new impending dangers.

The set described here is an "emergency" set to be used at just such times. It is a simple affair, the entire thing, batteries and set, being contained in a small portable carrying case measuring but 10 1/4 ins. long by 8 ins. wide by 4 ins. deep. All the components of the set are mounted on a single, 1/4-in. 3-ply wood panel covered with a leatherette material. The panel measures 4 3/4 x 7 1/4 ins. long. The set operates from 2 No. 6 dry cells; if greater volume is required, a "B" battery may be added. It may be made from spare parts lying around the house or laboratory; or since all the parts used are standard, they can be readily obtainable.

Figures A and B show the layout of parts. The tuning condenser is mounted at the bottom, the 5-to-1 ratio A.F.

transformer on top, the regeneration-control potentiometer in the center and the tube halfway up the panel on the left. To increase the sensitivity and selectivity of the set one of the new type iron-core antenna coils is used. The primary winding, however, in this particular circuit, is used as a tickler (regenerator) coil while the secondary winding is used in the conventional manner as a control-grid circuit coil. The tube is the type 1E7G, a 2-volt double pentode. Although designed primarily as a twin-pentode power tube it lends itself quite nicely to our purpose. One section is used as a regenerative detector and the other as a 1st A.F. To obtain as much gain as possible from this circuit a 5-to-1 ratio A.F. transformer is utilized.

The 10-ohm rheostat is used to drop the "A" supply voltage to the requisite 2 V. for the tube. This unit has a short, slotted shaft for screwdriver control since it requires only occasional adjustment to compensate for the wear of the dry cells. The filament "on-off" switch is combined with the potentiometer.

The parts have been so laid out as to make for shortest possible leads. Best results will be obtained by following this layout, illustrated in Fig. B. The set draws a total of 250 milliamperes so that the batteries will last a long while.

Figure 1 shows the circuit of this emergency set. It is the well-known, sensitive regenerative type using screen-grid control of regeneration. The small (mica-dielectric) variable condenser in the antenna circuit is used to compensate for

(Continued on page 632)

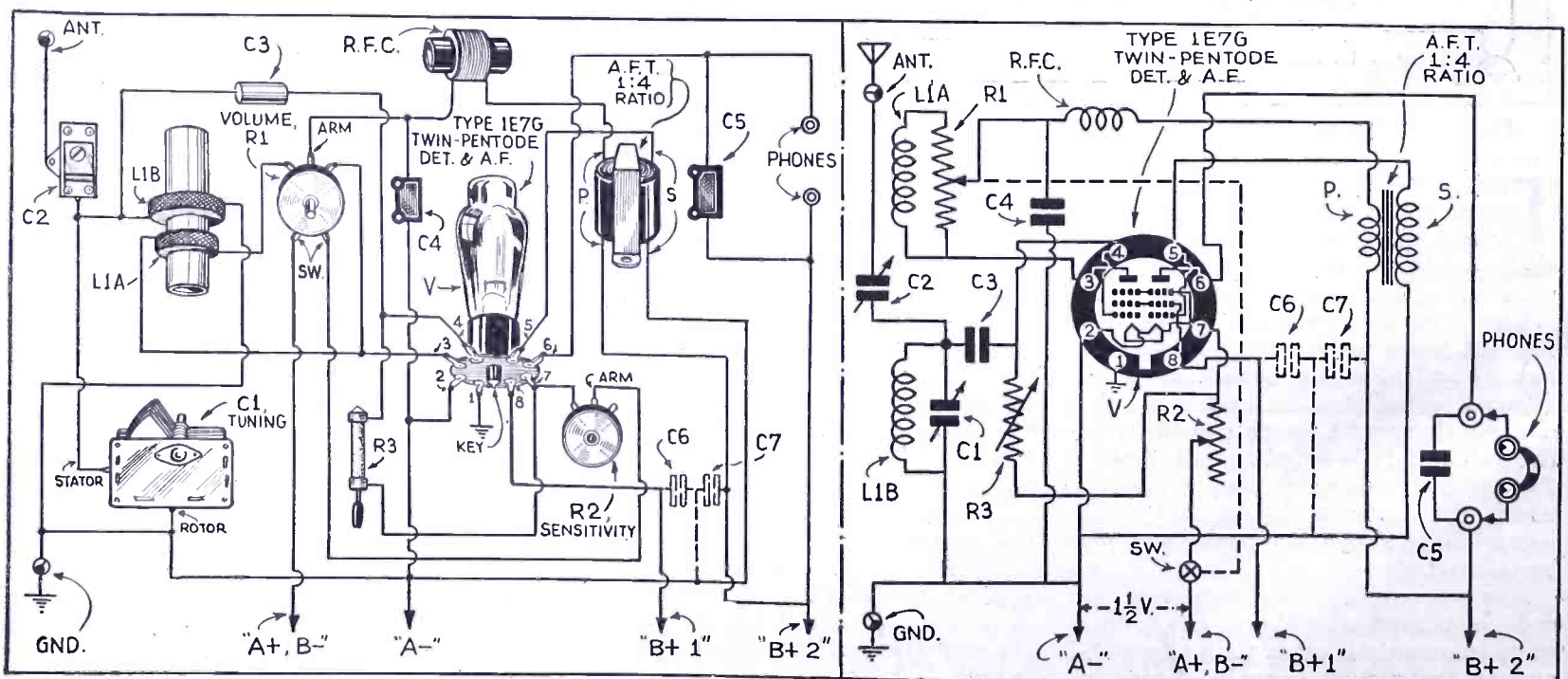

Fig. 1. Pictorial and schematic circuits of the broadcast-band receiver. A twin-pentode battery tube is used.

# "HURRICANE" STATIC!

Station WRUF in Florida is devoting much time to the location of hurricanes and storms by means of a novel recording scheme.

JOSEPH WEIL

**H**URRICANES cause much worry to many inhabitants of various parts of the world. Every geographical location on the earth carries with it serious and frequently difficult problems which require study, observation, synthesis and analysis. Problems which will have to be solved by those who have the talents, and who love their country and are determined to preserve and use its great natural resources.

The location of tropical storms by means of associated static is probably the first scientific attack upon this problem by Florida men. (The University of Florida has published a booklet that details work on this subject.)

The static crashes associated with a hurricane passing over Florida in 1928 were observed by experimenters at Houlton, Maine. Even 5 years prior to this, other observers at the National Physical Laboratories in England had been able to secure good correlation between readings obtained by an oscillograph (oscilloscope and camera) and the azimuth of lightning flashes near enough to be visible. Since 1928 other workers in Canada, Australia and the United States have made improvements on the apparatus used in the early experimental work. However, insofar as is known, none of the developments have produced apparatus that has proved satisfactory for quick, accurate weather forecasting, particularly with reference to hurricanes.

It was toward this end and with the idea of further

(Continued on page 640)

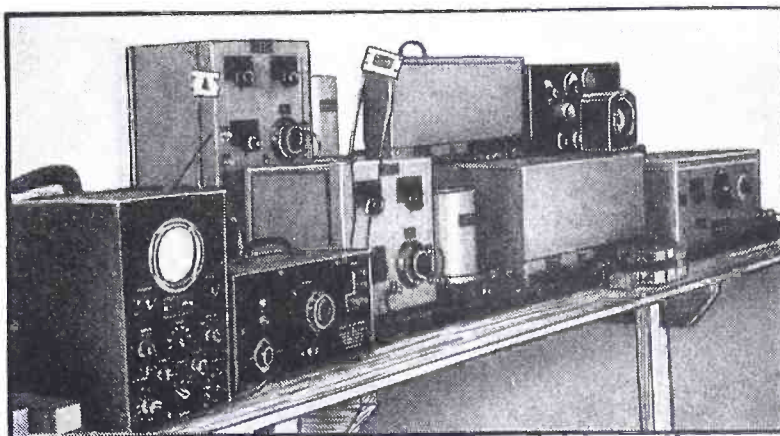

Fig. A. The recording set-up from tuners to the oscilloscope. This equipment is shown in block form in Fig. I.

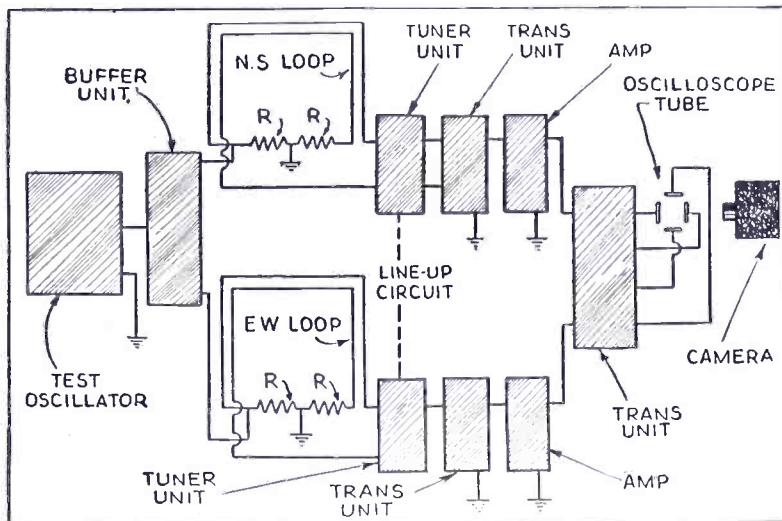
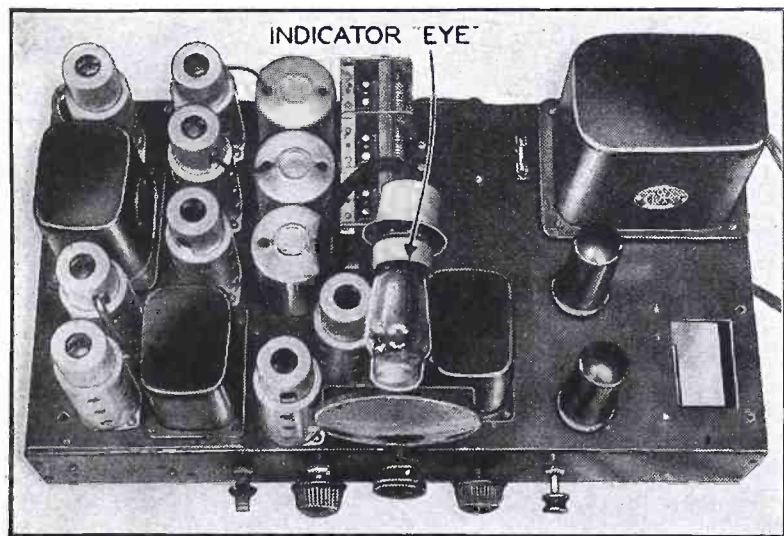

Fig. I. Block diagram of the equipment shown in Fig. A, plus the loops shown in Fig. B.



The appearance of the revised tuner chassis.

**S**INCE THIS receiver was originally described (in *Radio-Craft* for February and March 1936) it has been found desirable to revamp the audio system of the set to secure improved performance. The new audio system makes use of 3 stages instead of the former 2. The bass-booster action has been greatly improved by this change and in addition the volume of the set on the less powerful local stations has been increased. The bass booster is no longer in push-pull which greatly simplifies it.

It has also been found desirable to eliminate the A.V.C. action on the control-grid of the bass-booster tube. Careful listening tests on the receiver with

automatic and manual control available at the flip of a switch established the fact that the automatic control caused a peculiar effect on the reproduction of certain types of music.

The diode detector of the receiver was changed slightly to allow the single grid of the 1st A.F. stage to be fed from it in place of the push-pull arrangement formerly used and to allow the distortionless detection of high-percentage-modulation carriers.

The advent of the 6L6 "beam power tube" for the output stage of audio systems has made it possible to secure much greater undistorted output from the set with low overall distortion at all volumes.

## IMPROVEMENTS IN THE "12-TUBE HI-FI BROADCAST RECEIVER"

Changes in the A.F. amplifier and bass booster improve the operation on weaker stations, which is important in rural locations.

M. H. GERNSBACK

Reverse feed-back is employed in the power stage. The use of this arrangement reduces the power sensitivity or gain of the 6L6 tubes (which is normally as great as the power sensitivity of a power pentode) to approximately that of a power triode tube such as a 45. However, in doing this the odd-harmonics generated in the power stage, together with any hum or tube noise, is reduced to a negligible amount. (The push-pull action cancels even-harmonics.) Under the conditions obtaining in this set, without reverse feed-back, the pair of 6L6 tubes in push-pull would deliver about 25 W. of signal with about 2 per cent total harmonic

(Continued on page 633)

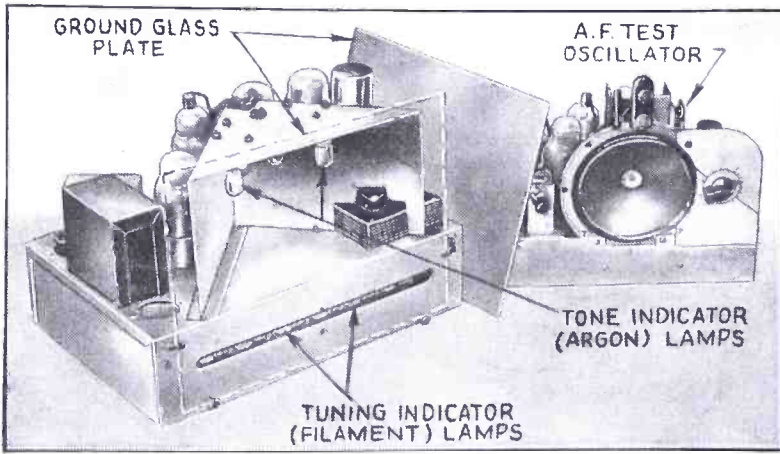

Fig. A. The Kaleidochrome chassis with a beat oscillator. Note the lamp positions.

# MAKING THE RADIO KALEIDOCROME COLOR-TUNER—TONE-COLOR ADAPTER

The radio experimenter and builder will find this add-on unit both an attractive and useful addition to a radio receiver having A.V.C.

CHARLES SICURANZA

**T**HE RADIO Kaleidochrome is a novel and useful add-on unit which can be connected to almost any receiver and which performs two functions—(1) it serves as a tuning indicator and (2) as a translator of sound frequencies into a vari-colored array of lights; a sort of radio “color organ.”

The portion comprising the tuning indicator (red glow—off-tune; green—in-tune, as used in the new 1937 General

Electric receivers) is entirely separate from the color organ and may be omitted at the discretion of the builder. However, in late-model receivers which have automatic volume control but do not have any tuning indicator built-in, it is certainly worth while to install the indicator in the Kaleidochrome, as a means of indicating the “point of best reception” of a station. The color tuning indicator has been previously available as an integral part of a radio receiver, and various types of color tone indicators have been described in the radio press, but the combination of both in a single unit, adaptable to any radio receiver, is believed to be an entirely new development.

## THE “COLOR ORGAN”

An auxiliary audio frequency amplifier in the unit is used to pick up audio voltage from the radio receiver and convert the amplified voltage to light, in various color combinations, by means of 4 special argon lamps (similar to the tiny neon lamps in appearance). These lamps are connected to resonant filters in the output of the auxiliary amplifier. The 4 lamps and their filters respond to 4 different bands of frequencies in the audio spectrum, and are colored as follows: Red, 400 cycles; Green, 800 cycles; Orange, 1,500 cycles; and Blue, 2,500 cycles. (The test oscillator used by the writer in resonating these several A.F. circuits, in order to determine the

(Continued on page 623)

## LIST OF PARTS

- One Allied Radio Corp. drilled chassis, size 11½ x 8 x 3 ins.;
- Four Radiotron, National Union, Triad or Tung-Sol tubes, 1—80, 1—42, 1—6C6, 1—76;
- One Kenyon power transformer, T1;
- One Aalloy filament transformer, No. 107-16, T2;
- One General Electric reactor No. RL310, T3;
- One Aalloy output transformer, type 809, Ch.1;
- One Kenyon filter choke, 30 hy., Ch.2;
- \*Four iron-core R.F. chokes, 10 mhy., L1, L2, L3, L4;
- One A.C. switch;
- Four Allied or Wholesale wafer sockets, one 4-prong, one 5-prong, two 6-prong;
- Four Stroblite tinted argon lamps, ¼-W.;
- Seven Allied Radio or Wholesale Radio Service pilot lamps, No. 40, 6 V., 0.15-A.;
- Four Allied Radio Corp. or Wholesale Radio Service Co. candelabra-base sockets;
- Seven Allied Radio Corp. or Wholesale Radio Service Co. pilot light sockets;
- One Cornell-Dubilier electrolytic condenser, No. EB8803, 8-8 mf.;
- One Cornell-Dubilier electrolytic condenser, 10 mf., 25 V., C1;
- Three Cornell-Dubilier tubular condensers, 0.1-mf., 400 V., C2, C3, C4;
- One Cornell-Dubilier tubular condenser, 0.01-mf., 400 V., C5;
- One Cornell-Dubilier tubular condenser, 0.05-mf., 400 V., C6;
- One Cornell-Dubilier mica cond., 0.001-mf., C7;
- One Cornell-Dubilier cond., 4 mf., 400 V., C8;
- One Cornell-Dubilier cond., 2mf., 400 V., C9;
- Two Cornell-Dubilier paper condensers, 0.5-mf., 200 to 400 V., C10, C11;
- One Electrad C.-T. wire resistor, 20 ohms, R1;
- One resistor, 500 ohms, 2 W., R2;
- One resistor, 1,000 ohms, ½-W., R3;
- One resistor, 50,000 ohms, 1 W., R4;
- One resistor, 0.1-meg., 1 W., R5;
- One resistor, 0.2-meg., ½-W., R6;
- Two res., 0.5-meg., ½-W., R7; R8.

\*Names of manufacturers will be supplied upon receipt of a stamped, self-addressed envelope.

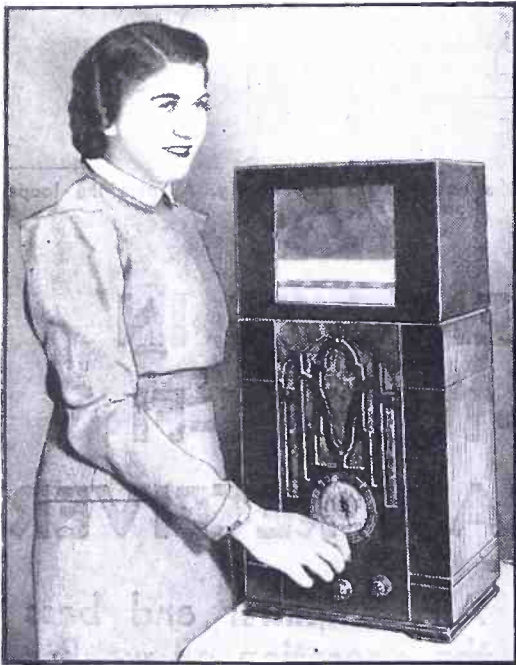

Fig. B. Here is the unit in operation, on a set.

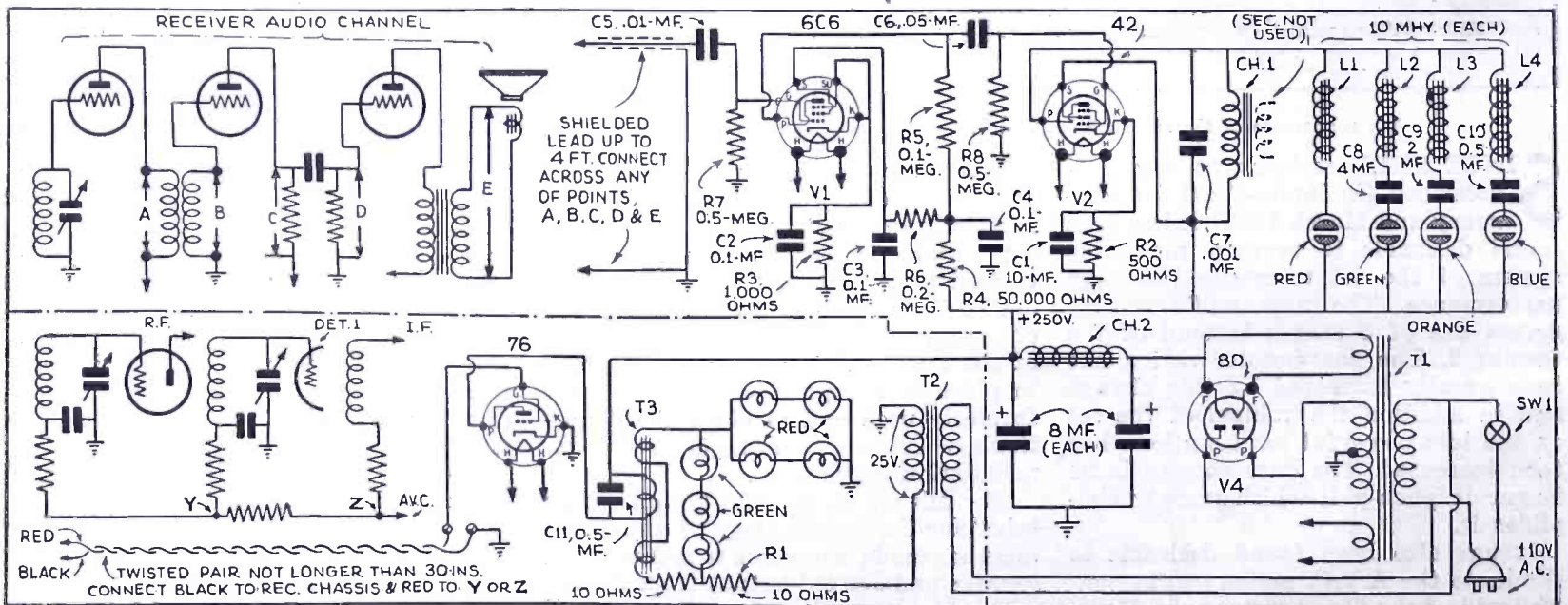

Fig. 1. The schematic circuit of the tuning indicator and the “color organ” unit. The device is easy to construct.

# MAKE THIS 1-TUBE "HOME BROADCASTER"

A useful device to convert any radio set into a P.A. system. It should find ready sale!

D. L. WARNER

EVERY OWNER of a radio set has, at some time or another, wished that he might be able to hook a microphone to said set. The desire is usually prompted by an idea that it might be a lot of fun to imitate some particularly well liked radio program for purposes of amusing friends or guests at a party, or just to "play around" with a "mike" to see what it feels like to be an "announcer."

Sometimes the set owner feels that the set might be pressed into service as a small Public Address System for some neighborhood or school activity. Since the average radio set is capable of producing a fair amount of volume, it stands to reason, argues the set owner, that there is or ought to be, some means of making it do other things than just bring in a few programs during the week. And if a small P.A. system is needed for only a short length of time, and since the radio receiver originally cost quite a bit of money, well, why not, and how can it be done?

The answer isn't nearly as difficult or as expensive as a lot of people have been let to believe.

First, and simplest is by means of one of the very cheap microphones readily obtainable at most every radio store or supply house. These "mikes" are usually fitted with a small wafer-type adapter that fits under one of the tubes

(Continued on page 627)



Fig. A. The "home broadcaster" used as a P.A. amplifier.

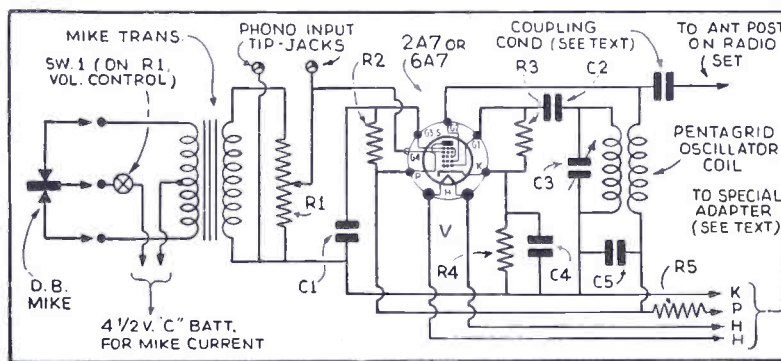

Fig. 1. The circuit of the adapter with parts values indicated.

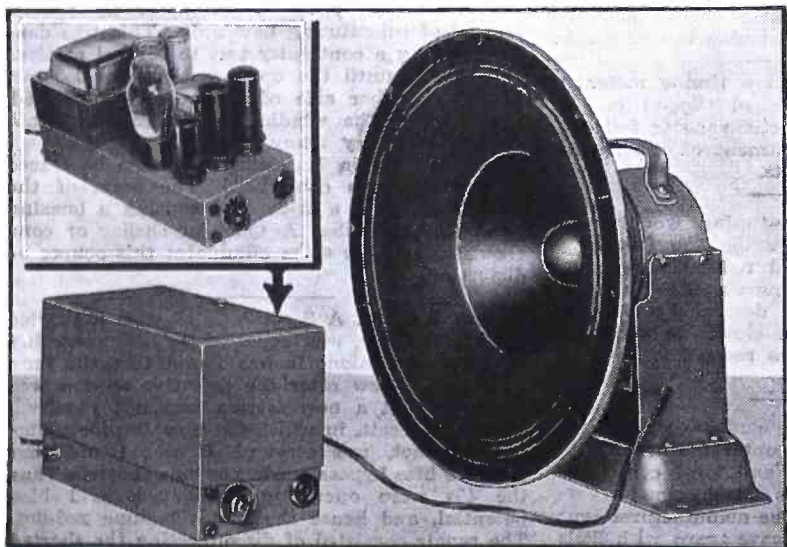

Fig. A. The amplifier and 18-in. speaker (chassis insert).

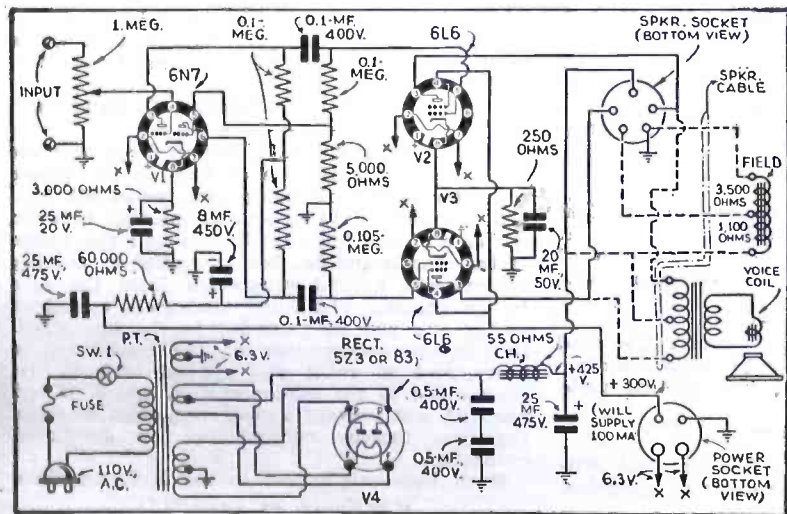

Fig. 1. The circuit of the amplifier—note its simplicity.

## HERE IS A GENERAL-PURPOSE HI-FI P.A. AMPLIFIER

A modern amplifier which, because of its high efficiency and economy, should interest P.A. men.

McMURDO SILVER

IT IS FELT that the A.F. amplifier illustrated and described herewith, and known as the Masterpiece 3-A Power Amplifier, will interest an unusually large group of readers, so flexible is it and so manifold its uses. It has been designed primarily for Public Address use in line with the modern school of engineering thought which is rapidly realizing the efficiency and economy of separating low-level, high-gain voltage amplifying equipment from power amplifying apparatus. Thus it may serve as the complete power amplification unit of a P.A. system large enough to cover a 20,000-person audience while the addition of one or two more of these units with suitable speakers would quite easily cover a half-million people.

In order that it may be quite flexible, and be capable of being driven by preamplifiers having little or no actual audio power output, it must require no driving power, and have sufficient gain in itself to require no excessive preamplifier gain. A suitable order of gain is such that it may be driven directly by a crystal or good magnetic phonograph pickup. Thus it may also serve, not only as the fundamental power amplifier of a P.A. system, but as a booster amplifier for

(Continued on page 619)

# OPERATING NOTES

## ANALYSES of RADIO RECEIVER SYMPTOMS

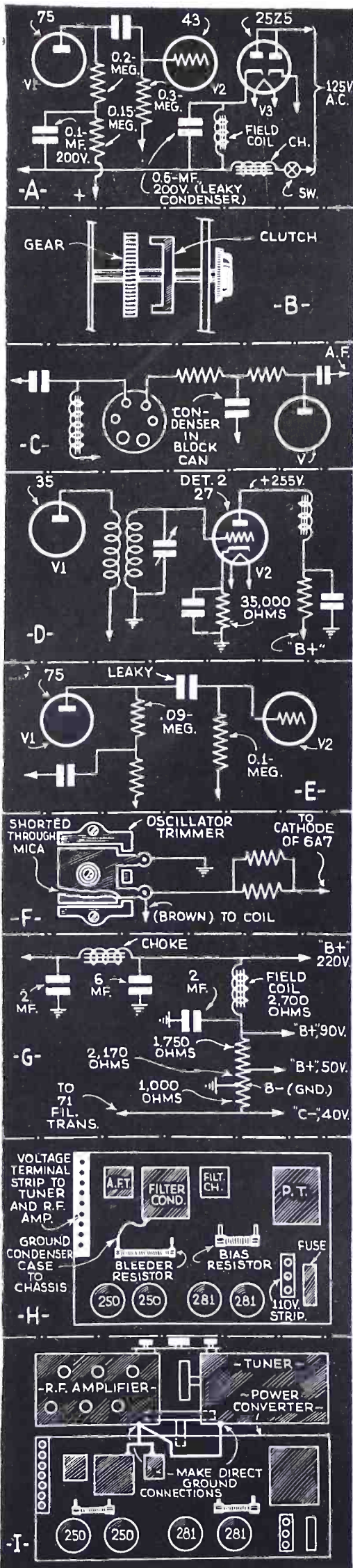

Fig. 1. Detail circuits discussed.

**Emerson 107.** The Emerson 107 frequently is troublesome. Several of these sets which have been repaired were unsatisfactory on 3 counts: (1) low output, (2) distortion or intermittent operation, and (3) no reception.

In the latter cause a voltage analysis will probably disclose the trouble; often it is a shorted electrolytic condenser.

An unusual case of distortion was traced to a 0.5-mf. condenser across the speaker field. See Fig. 1A.

A high-resistance ohmmeter indicated leakage in the unit. The fault went undetected when the customary trouble-shooting procedure of bridging the condenser with another capacity was employed.

Additional points to check are the 0.01-mf. grid condenser and the plate filter of the type 75 tube, a 0.1-mf. unit. A peculiar form of intermittent reception was found in the trimmer condenser located in the rear left corner of the chassis. Jarring the set occasioned a short through the mica insulation. A factory replacement was obtained and functioned "beautifully."

A loose wire on the coil, near the trimmer condenser just mentioned, once caused a form of intermittent operation wherein the set would function in positions differing from the correct (horizontal) one.

**Halsen 50R, 5LR, 60M.** Common trouble: filter condenser defective at input to filter, characterized by distortion, hum or inoperative condition.

**Philco 611F, 660.** Noisy volume controls.

**Philco 47.** Intermittent reception, frequent burnout of tubes and pilot lights, is often due to a short in the set between chassis and the pilot light socket behind the shadow tuning meter.

**Philco 665.** Defective shadow timing meter; a small spring in the unit had slipped out of position allowing the magnetic vane to fall out. The replacement and adjustment of the spring were made with good results.

**RCA C-94.** Dial on fine-tuning would work satisfactorily but on fast-tuning the frequency indicator on the dial would remain stationary. On this model the dial tuning speed variation is accomplished by a clutch device. By slightly squeezing the ends of the clutch to secure a firmer hold on the gear, the remedy is effected. See Fig. 1B.

**Philco 116X.** Noise and double-spot tuning. An odd situation was encountered where, with the set balanced perfectly and local conditions better than average, stations would seem to come in at 2 points on the dial. The manufacturer sent up a man who installed 2 wave traps with little success. Finally, the writer discovered a couple of kids "fooling around" with a 500-ke. oscillator they were using in some jazzed-up broadcast set.

**American Bosch 505.** Trouble: noise; remedy: new volume control.

**Philco 54C.** Trouble: noise; remedy: new volume control.

**Emerson 107.** Common trouble (Intermittent reception or distortion caused): condenser at cathode of 25Z5 (blue lead into small can of condensers) frequently fails. Replace with 8-mf., 175-V. unit. See Fig. 1C.

**Majestic 20.** Set reported "dead". The 2nd 175 kc. I.F., (2nd-det.) shorts to chassis, causing low voltage or no-voltage on type 35 tube plate (Fig. 1D).

**Philco 655, 660, 54, 611.** Shorted grid condensers cause intermittent or distorted reception. See Fig. 1E.

**Philco 611.** Set dead; replaced filter condenser and 78 I.F. screen-grid resistor which restored operation but accompanied by a peculiar periodic clicking. A leaky oscillator padding condenser, part No. 60-3027, caused the trouble—and a headache. (Fig. 1F.)

WILLARD MOODY

**Majestic 71.** A common failing in the 71 series of Majestics is the dial cable. When replacing the broken cable by a ready-made part, it is essential that the correct procedure be followed, otherwise the replacement part will not fit. The writer has found that the following sequence of operations gives a minimum amount of trouble.

First, remove the broken cable, then connect the center lug of the new cable to the screw on the dial drum, and turn the dial to the 550 kc. position. Next, put one end of the cable over the drum and slip the lug on the end of the cable over the pin (not under the screw) on the dial shaft. Then by turning the dial shaft, bring the dial to the 1,500 kc. position and lock it in place by slipping an old bakelite dial on the dial shaft so that the dial jams against the chassis. Then pass the other end of the cable over the drum and over the cable pulley and take up the slack by wrapping the loose end of the cable around the cable-groove on the shaft. Finally, anchor the cable lug under the screw on the shaft. The important factor to remember is:—start at the pin end of the shaft, not at the screw end.

A second failing in the 71 series is the speaker field. The speaker field on this model serves as part of the voltage divider as shown in Fig. 1G. The indication of an open field is zero voltage on the plates of the R.F. and detector tubes. The writer has repaired several of these fields instead of substituting new units. This was done by applying a continuity test to several sections of the coil until the open section was located. Wires on either side of the open were joined, thus making the winding continuous while not cutting out very many turns.

Poor quality in Majestics can often be traced to the speaker's cone head. The seam of the cone head opens a trifle thus causing a buzzing noise on bass notes. A touch of shellac or cone cement along the seam eliminates this source of distortion.

**Scott A.C. 10.** A Scott A.C. 10 with a shorted filter condenser was repaired by disconnecting the shorted section. It was found that the hum level was so low after the defective section was removed, that a new section was not required.

Another Scott, in which the type 45 tube plates were red-hot, was serviced. It was found that the grid bias bypass condenser was shorted. Thus the 45s were operating without a grid bias potential, and hence the plates became red-hot. The repair consisted of disconnecting the shorted section. A replacement unit was not used because, as shown in the January and March 1932 issues of *Radio-Craft*, there should not be a bypass condenser across the grid bias resistor of a push-pull amplifier. (There are exceptions. —Editor)

WALTER G. CHRISTIE

**Sparton Model 301 A.C.** Quite a frequent cause for an exaggerated case of hum in the power converter section of the Sparton model 301 A.C. has been traced to a poor connection between the case of the filter condensers and the frame of the chassis and has been remedied by making an external ground connection from the case to the chassis. The filter condensers contained in the can are all grounded to the can itself. During the construction of the converters, a heavy coat of paint was applied both to the chassis and to the condenser can, which, if not removed, will prevent a good connection between the two, thereby necessitating an additional connection.

Much hum originating in the R.F. amplifier (Continued on page 616)



# MAKE THIS POCKET-SIZE METER RECTIFIER

This is an add-on unit, for the pocket-size multimeter, described last month, to permit measurement of A.C.

MILTON REINER

**T**HE POCKET Multitester described by the writer in last month's *Radio-Craft* was designed for D.C. measurements only. Of course the great majority of trouble shooting and radio servicing requires only D.C. measurements but there are a number of in-

stances when A.C. voltage measurements are decidedly helpful. In fact there are some occasions when they are absolutely necessary.

### PROS AND CONS

The meter should respond with reasonable accuracy to all frequencies within the audio range. The iron-vane type of meter, has a low sensitivity and is exceedingly inaccurate for this purpose, although it is included in some commercial testers now on the market. Electro-dynamometer instruments are fairly low in sensitivity as well as expensive and have limitations at the upper end of the audio range. The hot-wire type of meter is not able to stand much overload and is not adaptable for rough usage and multi-range design. The thermocouple type is of course ex-

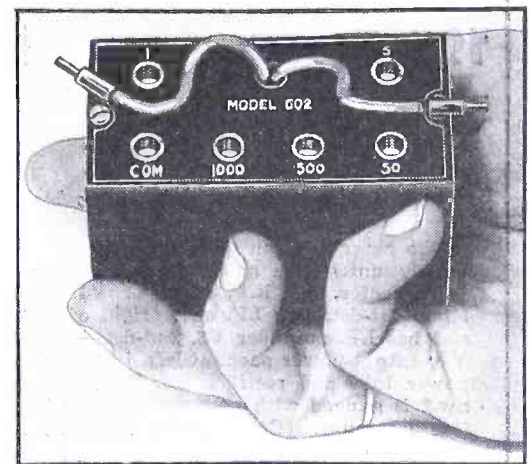

Fig. A. The unit in its tiny box—completed.

pensive and delicate, and is somewhat sluggish; although, it is highly accurate at all frequencies. The electrostatic type of meter is also impractical for service  
(Continued on page 635)

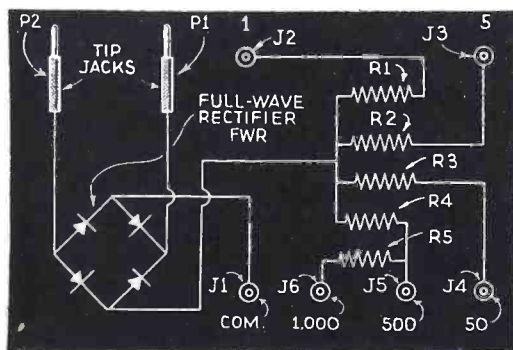

Fig. 1. The circuit of the rectifier unit.

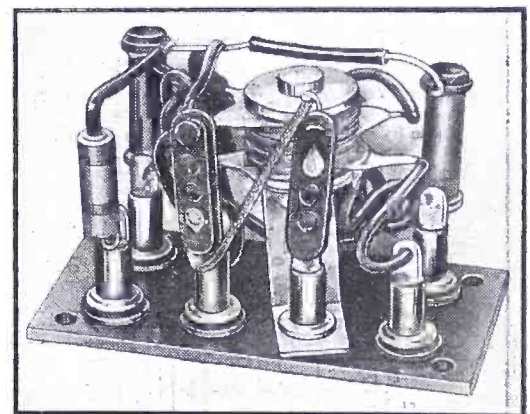
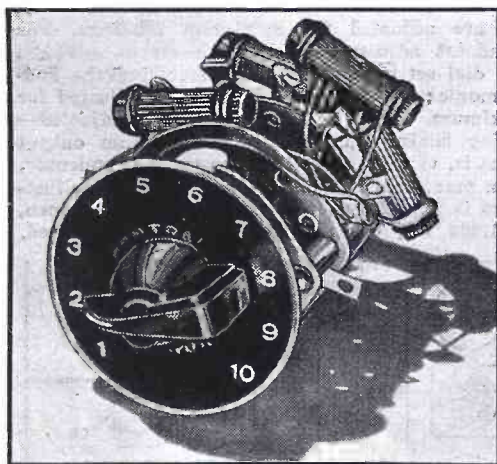

Fig. B. The rectifier and resistors can be seen.



## PRACTICAL RESISTANCE AND CAPACITY DECADE BOXES

By a clever application of switching facilities, these two useful devices are brought within reach of all Service Men.

WILLIAM H. FRITZ

finger's tips on a moment's notice! Decade resistance and condenser units that are the equivalent of these mythical boxes will be described in this article.

### DECADE RESISTANCE UNIT

The decade-type resistance box con-

tains 4 selector switches, each connected to 4 resistors. This makes a total of 16 resistors to yield the amazing number of resistance values named. It is the function of the selector switches to connect the resistors in series in the proper order to accomplish this result. By  
(Continued on page 617)

**I**MAGINE having two boxes on your work-bench—one containing 9,999 resistors and the other containing 10,000 condensers—with any one of the values in either box available at your

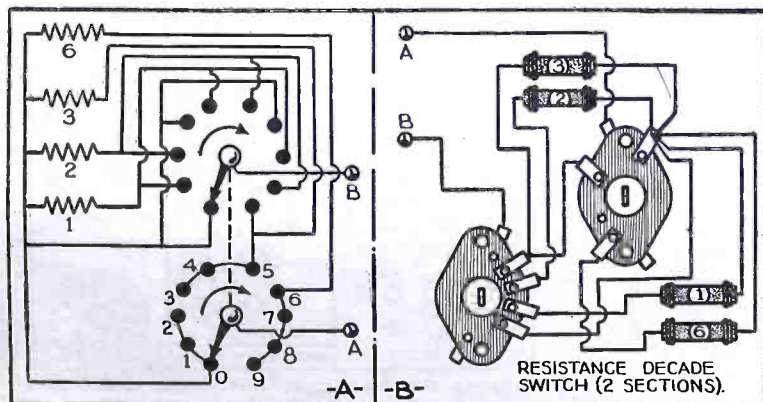

Fig. 1. Schematic and picture circuits of resistance decade.

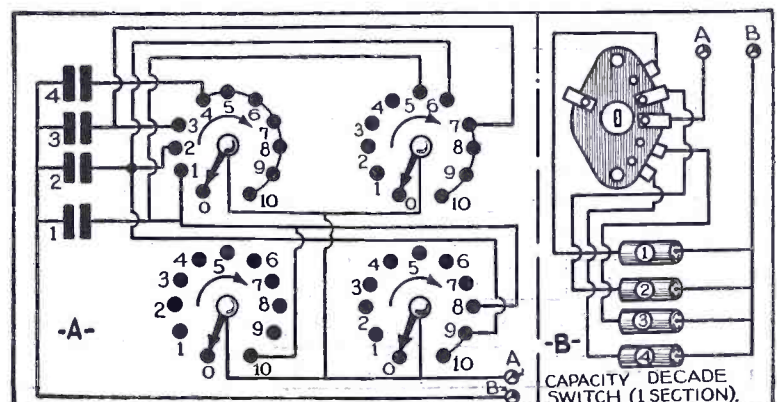

Fig. 2. The circuit arrangement used for the capacity decade.

PHILCO MODEL 37-620

A 6-tube A.C. superhet., glass tubes, A.V.C., bass-compensated vol. control, 3-range (530-1,720 kc.; 2.3-7.4 mc., 7.35-22 mc.).

The chassis is constructed in 3 basic assembly units (see small diagram below); R.F., center, has R.F. amplifier V1, oscillator—1st-det. V2; I.F. unit (right of chassis) has I.F. amplifier V3, 2nd-det.—A.V.C. V4; output-power pack, at left, includes V5, power tube and rectifier V6. Tone control Sw.2 is ganged with power switch Sw.1 on this last unit. (Compensator locations in separate diagram.)

Philco "foreign tuning" system incorporates a multiple switch, the numerous connections of which are detailed at the upper right of the large schematic diagram. The antenna terminals 1 and 2 are intended for

connection across a dual transmission line, with jumper across 3 and 4; but a single leadin may be used on 1, with jumper across 2 and 3 and the latter connected to a good ground.

While circuit was unchanged in this model, in later assemblies input filter condensers (110-V. line) were removed from front to rear of the chassis; and 0.03-mf. condenser in plate circuit of V5 mounted in their place. It is a bakelite, not tubular, condenser, in the second run.

When replacing any part of the speaker, be careful to connect hum-back coil terminals with the polarity for minimum hum.



Philco 620CS (Chair-Side Cabinet)

Adjustment is begun by centering the glowing beam of indicator on first line of the dial scale, with tuning condenser at maximum setting. The I.F. amplifier is then peaked at 470 kc., adjusting CQ, CP, CO and CN, in that order. Trimming R.F. compensators is done first on 18 mc. (To overcome detuning effect on the oscillator circuit, a 350-mmf. vernier condenser is connected across CB and tuned till 2nd-harmonic of the oscillator beats against signal.) Set units CF and CI for maximum output; external condenser is removed; and CM turned clockwise to maximum capacity, then backed off to second peak, to avoid image frequency (first peak). With range switch at middle (police band) setting, and an input frequency and dial setting of 7 mc., CL is adjusted for maximum setting; then, at 6 mc., CH and CE are adjusted for maximum readings. For broadcast adjustment, signal input at 800 kc., and dial setting at 1,600 kc., receiving the 2nd-harmonic; CJ, CG and CD are then adjusted for maximum. Then, at 600 kc., CK is adjusted—rolling tuning condenser for maximum output (that is, varying first CK, then tuning condenser, till a maximum is found near 600 kc.). Readjustment is made at 1,600 kc., as before; and then, at 1,500 kc., CD and CG are finally adjusted.

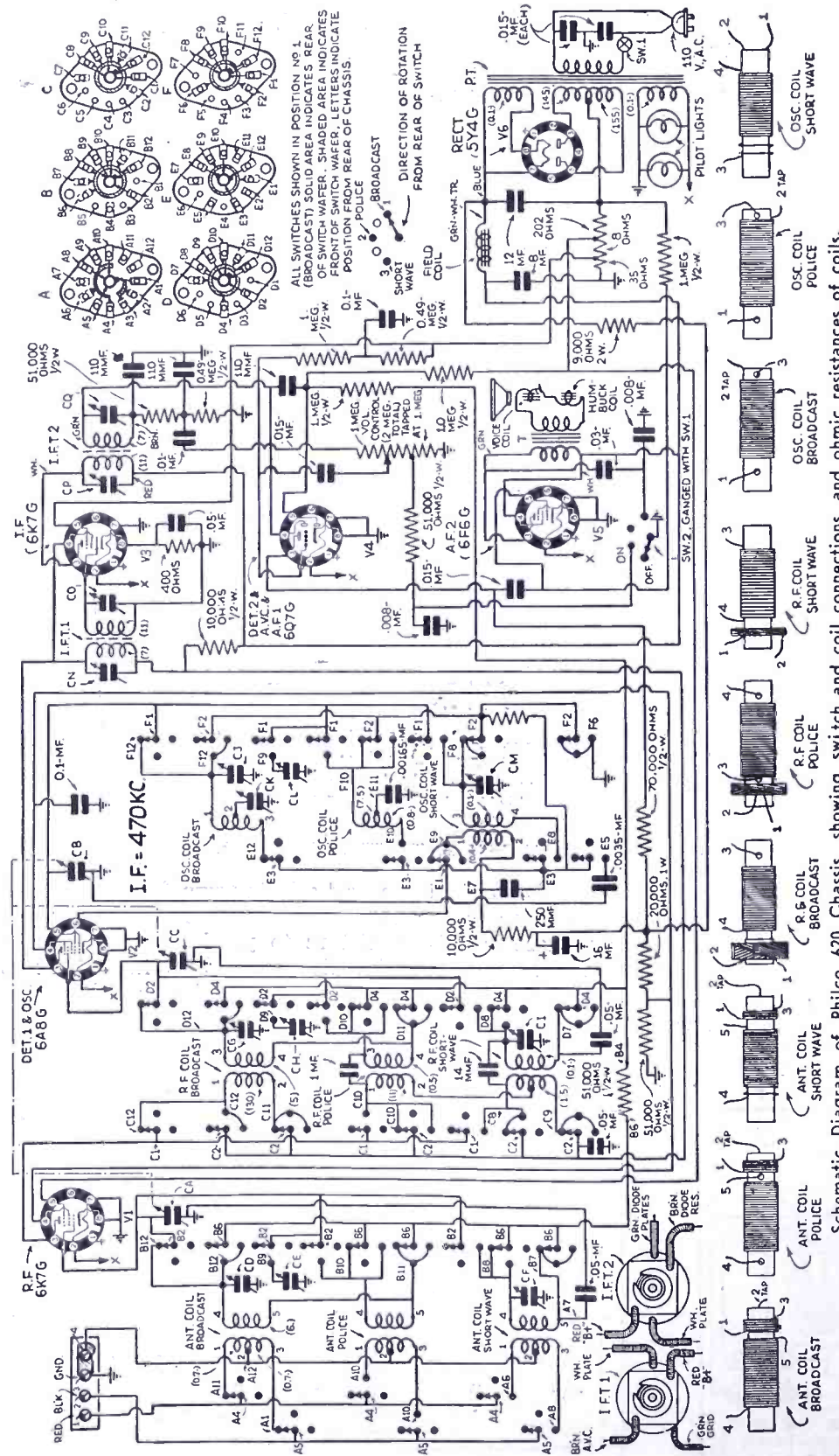

Schematic Diagram of Philco 620 Chassis, showing switch and coil connections, and ohmic resistances of coils.

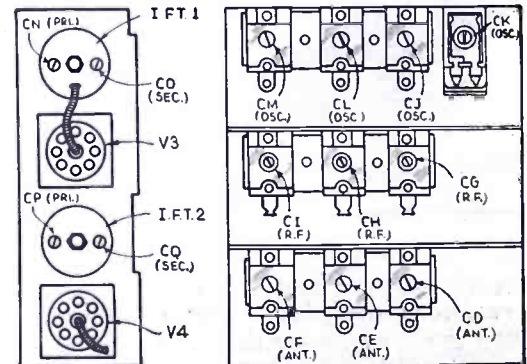

Positions of compensators (see above).

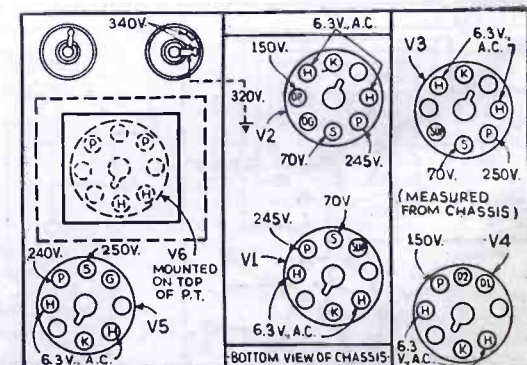

Voltages at tube socket; 115V. input, broadcast range, vol. con. at minimum.

## EMERSON MODELS L117, L122, L133, L135, L141, L150 (Chassis Model L)

Five-tube A.C. Super., 2-range (540-1,750 kc., 2,200-7,500 kc.), A.V.C.

Note 1: Data apply to receivers with serial numbers above 895,962. In those below No. 961,900, primaries of antenna coil are in parallel, and a 50-mmf. condenser in series with antenna lead and S.W. primary; C17 is .00135-mf. Speaker, L135, 10 ins.; others, 6½ ins.

Note 2: In Model L150, C28 is 8 mf., 450 V.; C29 mf. 450 V., both dry electrolytics. In other models, both are 16 mf., wet type.

Color coding is (generally): Plate, blue; "B+", red; screen, brown; cathode, white or yellow; grid, green; filament and ground, black. I.F. transformers are coded accordingly. Power transformer is coded: Pri., black; high-voltage sec., red, with center-tap red and yellow; V5 sec., green; 6.3 V. sec., yellow.

Voltage readings, with 1,000-ohm/voltmeter, at 117.5 V. line, are as follows (to chassis):

	Plate	Screen-grid	Cathode
V1	255	90	3.5
V2	255	90	3.5
V3	120	—	1.8
V4	240	255	15.0

On oscillator plate (G2 of V1) 170 V.; at

filament of V5, 325 V.; field, (5-4) 70 V.

In adjusting the receiver, I.F. transformers are found above chassis, with trimmers reached through holes in cans. I.F.T.2 is behind tuning condenser. At 456 kc., trimmers are adjusted for maximum response, and C6 (wave-trap, between V1 and I.F.T.) for minimum.

On the S.W. band, signal is fed in at 6 mcs., with a 400-ohm dummy antenna. Adjust C7 (beside C2-C3, nearest front) and C4 (left side chassis top, nearest front). Be careful to find minimum capacity peak on oscillator (maximum on antenna trimmer). Padding condenser C17 is fixed mica type; if it is replaced, this capacity (within 2 per cent) must be duplicated, or S.W. tuning will not track.

Adjust B.C. band padder at 600 kc. C16 (near 6A7 tube) is set at minimum-capacity peak of response. Adjust B.C. band trimmers C8 (beside C2-C3, rear) and C5 (left side rear) at 1,600 kc., rocking tuning condenser.

Always tighten trimmer with last motion—do not loosen it. If outside plate is so loose there is no tension on screw, bend up plate or remove screw.

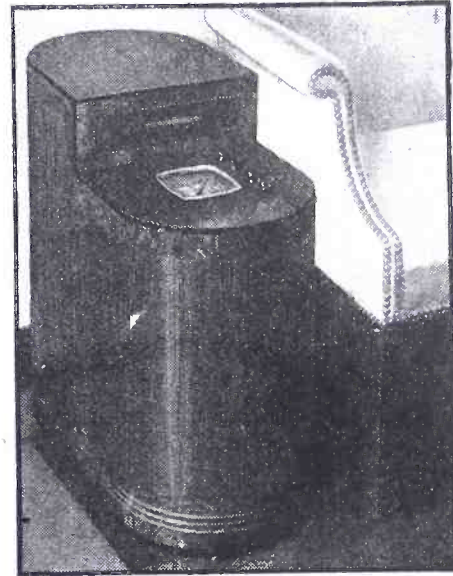

Model L-150 (Chairside)

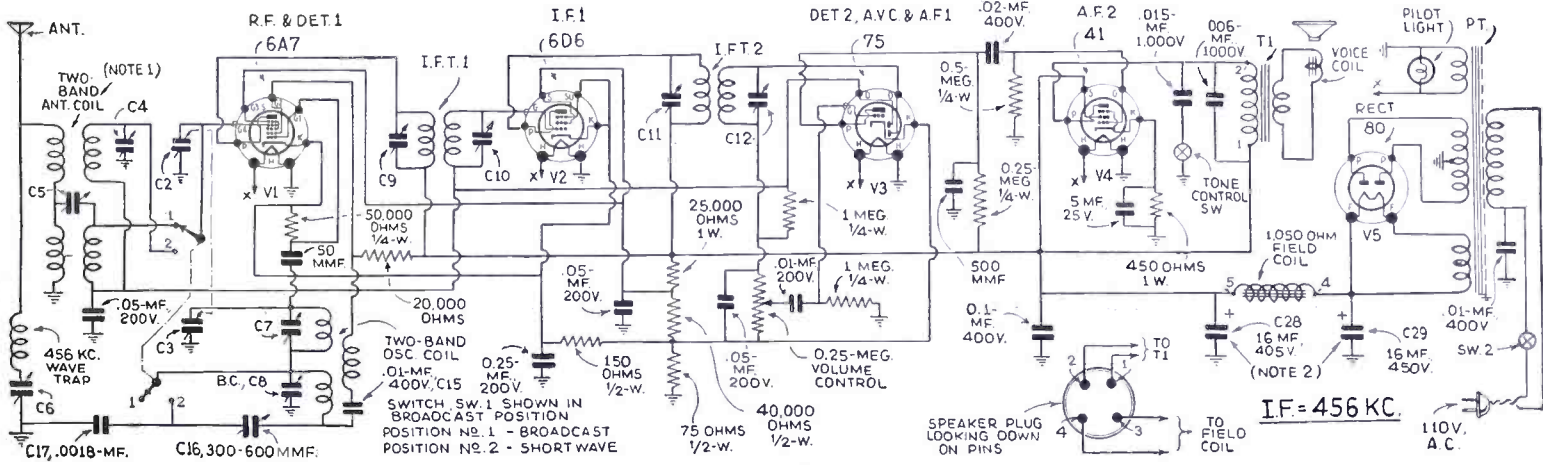

## EMERSON MODELS A130, A132 and A148 (Chassis Model A)

5-tube A.C.-D.C. Superhet, 2-range (540-1,700 kc.), A.V.C. in later sets.

In sets below Serial No. 799,301, Circuit No. 1 was used, with V3 a 76 triode. Up to No. 819,200, Circuit No. 2 (dotted parts in, X-ed connections out). From No. 819,201, Circuit No. 3 (dotted parts removed, R14 and R17 inserted as shown). Voltage Readings (at 117.5 V., A.C.):

	Plate	Screen-grid	Cathode	Cathode
			Circuits	No. 1
V1	112	50	1.5	2.5
V2	112	112	4.6	5.5
V3	*60	6	0.5	5.0
V4	100	112	15.0	15.0

\*In Circuit No. 1, 50 V. on V3 plate.

Oscillator plate voltage (G1 of V1) 112 V. Across field coil, 125 V.; across Ch.1, 12 V. Across R10 (ballast tube) 45 V., A.C.; across pilot light, 4 V., A.C.

I.F.T. 1 is oblong can, behind C2-C3; I.F.T. 2 round can at right of speaker, and has a single trimmer. R.F. trimmers (not diagrammed) are on variable condenser top—C2 front, C3 rear.

Receiver is adjusted at 456 and 1,500 kc. I.F.T. 1 is plug-in type; unsolder leads and lift out. (Color code as for Model L, above.)

CAUTION: power line is grounded to chassis base!

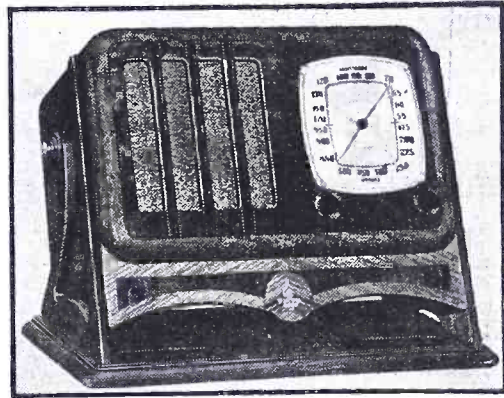

Model A-148

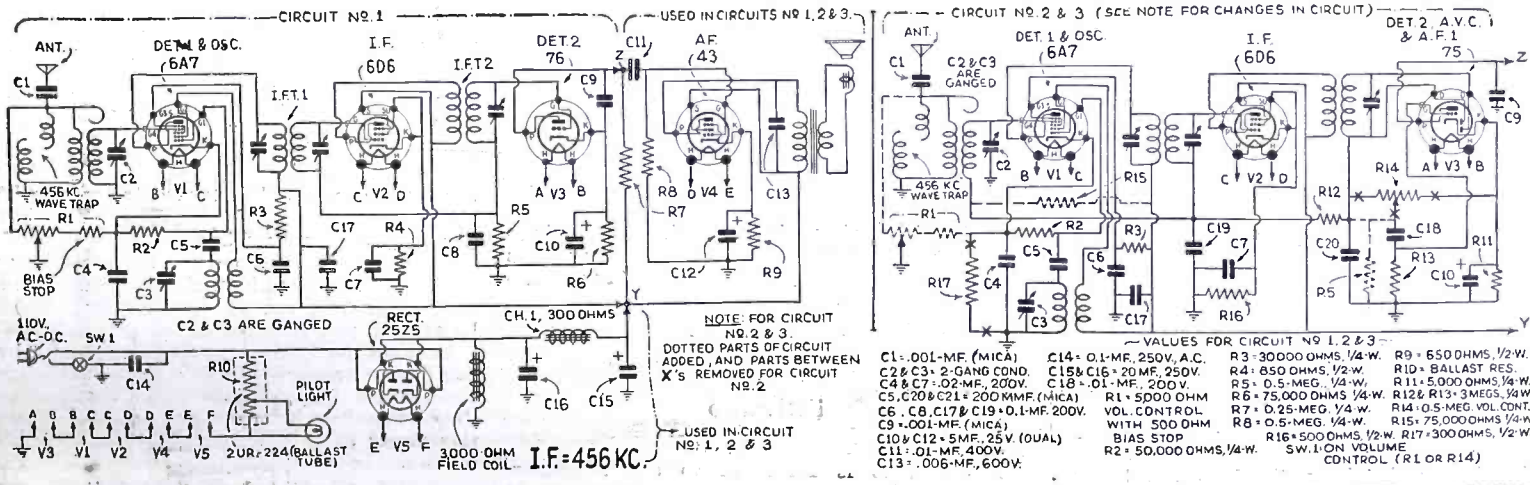

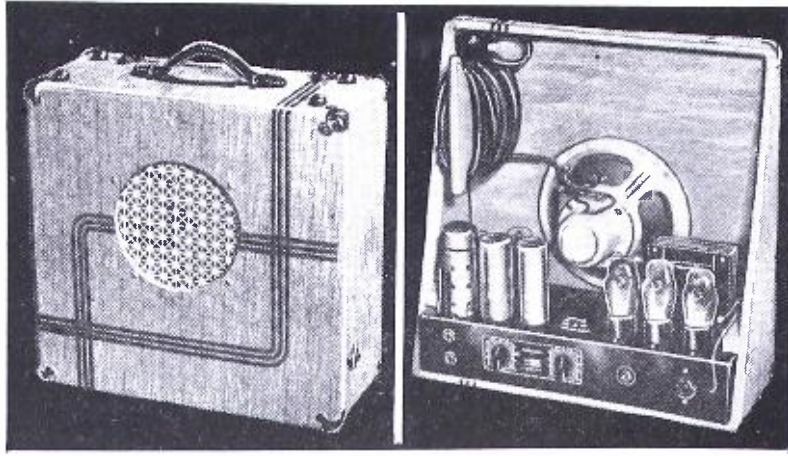

The complete amplifier and speakers fit into a split case.

**J**OHN STEFAN is a bright, young radio technician who possesses his own modest establishment and an inordinate capacity for griping. Because of our soft nature which includes a work phobia acquired as a childhood disease, we often drop into his shop to discuss this and that and to serve as a convenient target for his multitudinous gripes. For one thing, we are a member of the slide-rule fraternity, and Johnny places slide-rules and spinach side by side.

Howsoever, his pet peeves make another story—a long one. Something, other than the battle between theory and practice, was on his mind as he guided us into his be-metered sanctum sanctorum this bright and cheery afternoon.

"Here, sit down," he invited, waving to a storage battery and reaching his other hand into our cigarette pocket. We thanked him, swept a high-fidelity midget receiver (!) and an oscilloscope from the bench to the floor and sat ourselves on the clearing thus made. He didn't bat an eye—that gave us plenty to wonder about. In turn, he collapsed gently on a 12-volume set of "Magnetic Personality—Yours For the Asking" that was spread, divan fashion, over the floor,

## P.S.: "HE MADE THE SALE!"

Breaking into P.A. work does not necessitate a large investment if you tackle the job right!

H. M. BAYER

propped his heavy head on the storage battery and proceeded to enlighten us.

"I'm rich"; he informed us after a deep drag on our cigarette, "I've just finished a P.A. installation in our local church, and signed a contract for another in the Elk's Club. Want to borrow any money?"

We rendered the looked-for gasp of awe at the first part  
(Continued on page 634)

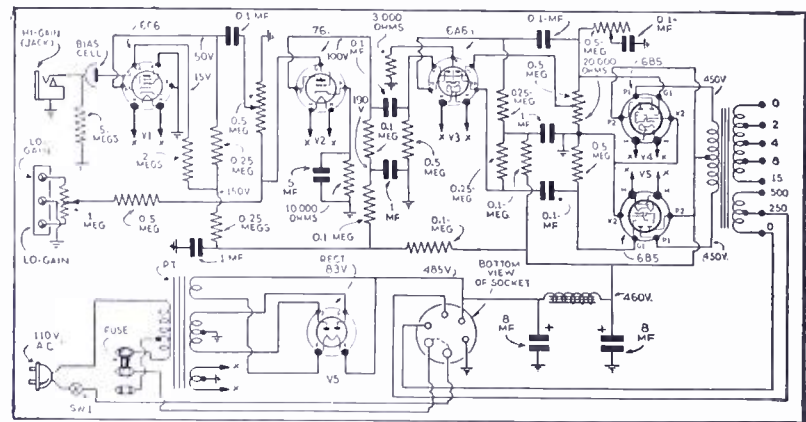

The circuit of the amplifier shown in the photo, above.



A department devoted to members and those interested in the Official Radio Service Men's Association. For mutual benefit, contribute *your* kinks, gossip and notes of interest to Service Men, or others interested in servicing.

### BRITISH WEST INDIES: WANTS ORSMA DATA

RADIO-CRAFT, ORSMA Dept.:

I have just completed an English correspondence course in wireless telegraphy and telephony, which will entitle me on the arrival of my diploma to use the initials A.M.I.E.T. and in the next few months an American course in practical radio, but could not do without for-

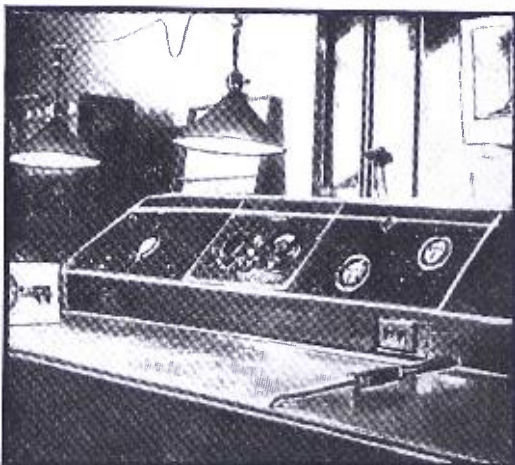

Service Men will take a tip from this layout—note the effective angle of the panels.

warding these few lines to you, as I have had an attempt at a model RCA R15 receiver, an American-Bosch model 260, a Fada, and an RCA model 141 Magic Brain, without any good results whatever. I am in possession of an analyzer, which plugs into the receiver while in operation, has a 7-prong adapter cable, D.C. 0-600 V., 0-0.3-meg. and 0-15-150 ma. When using the ohmmeter, with the set turned off, a 4.5 V. "C" battery is connected to it. My ambition is to be a Service Man, the kind that does not fail, whether a diagram is to hand or not, and I am therefore looking forward for information regarding the requirements of the Association from those desirous of becoming members or associates that I may determine the class to which I will enroll.

EMANUEL C. RAYMOND,  
Lagon D'or Street,  
La Brea, Trinidad, B.W.I.

In Great Britain radio is still "wireless"! Anyway, we extend Mr. Raymond our best wishes that he achieve his ambition to become a "successful" Service Man.

### HOLLAND: DESIRES ORSMA DETAILS

RADIO-CRAFT, ORSMA Dept.:

Although it is forbidden to sell American radio sets here, we have regularly to repair

them. So we have service of them! Therefore it is of great importance that we are kept up to date regularly. We will take therefore a subscription on *Radio-Craft* this week.

As I have regularly published about practical and theoretical problems of receivers and transmitters I have got here a sort of popularity. Also my study as an electrotechnical engineer at the University Delph (Dipl. Engineer) has brought me the wanted knowledge supported by my sports.

In different radio technical papers I still publish. I send you herewith some copies to underline my words and to show you the worth of my brains. (Several clippings on technical topics were enclosed.—*Editor*) I should like to ask you full details about the membership of the ORSMA. I read about it in the 1935 Official Radio Service Manual of Gernsback. I also wrote Gernsback Publications, Inc., to ask them if my office can get the representation slip. As a Service Man, writer, I can perhaps do much for you and for their publications.

Now I have to ask you for the possibility that I get the membership certificate called in that book page 1003 nr. 14. The money (60c) will be sent to you immediately after receipt.

For you perhaps it is also very useful that you have a connection here who is known among the Service Men. And perhaps I can examine the other askers here and you can give them also this paper as they have passed my little examination.

(Continued on page 625)

**AWARDS IN THE CONTEST**  
**FIRST PRIZE** ..... \$10.00  
**SECOND PRIZE** ..... 5.00  
**THIRD PRIZE** ..... 5.00  
**Honorable Mention**

# USEFUL RADIO CIRCUITS

Experimenters: Here is your Opportunity to win a prize for your pet circuit idea, if it is new, novel, and useful.

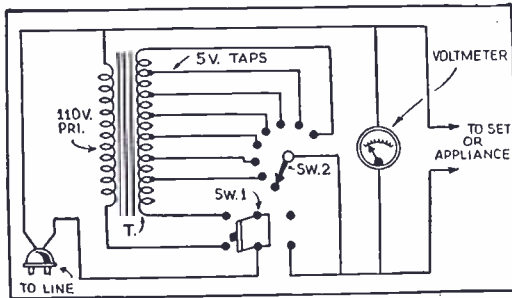

Fig. 1. A line-voltage booster which permits the radio set to work in spite of low voltage.

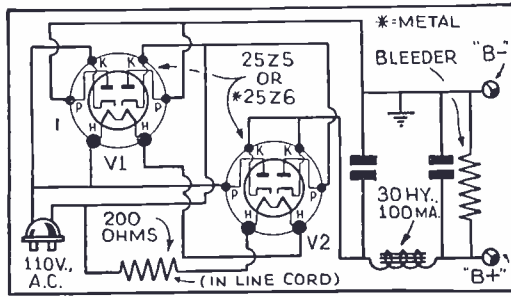

Fig. 2. A full-wave power supply system for small sets, speaker field supply and other uses.

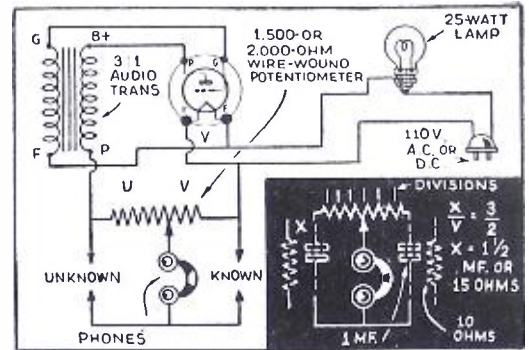

Fig. 3. A simplified A.C. bridge unit.

## FIRST PRIZE—\$10.00

**Line-Booster Transformer.** In locations where the line voltage drops 10 or more volts during the hours of peak load, radio receivers and some other appliances do not function properly. A booster transformer can be added to the line circuit feeding the individual appliance and thus step up the voltage. Such a scheme is shown in Fig. 1. The transformer T should have a rating in watts equal to, or greater than, the appliance to which it is connected. The transformer should have a 110-V. primary and a secondary tapped in 5-V. steps. The

secondary is connected in series with the line and the transformer of the appliance. The secondary must be connected "series aiding" or in other words in phase with the other transformer.

Switch Sw.1 is the on-off control for the booster. When turned to the left it cuts in the booster and in the right-hand position it removes the booster from the line circuit. When the booster is being used the A.C. voltmeter M should always be in the circuit to prevent application of excessive voltage. Switch Sw.2 controls the amount of booster voltage added to the primary circuit of the radio set transformer.

W. T. MOORE

when compared to a 10-ohm resistor it is 15 ohms.

To arrive at the plate resistance of a tube, the tube should be connected with "A," "B" and "C" batteries of correct size for the particular tube operation desired and the negative lead from the "B" battery to cathode should be opened and connected to the "unknown" terminals of the bridge. Then by inserting a suitable known value of resistance in the "known" side, the ratio of plate resistance to known resistance can be determined.

In the comparison of inductive reactances, an inductance having a known reactance is inserted in the "known" side of the bridge and the unknown inductance in the "unknown" side. The bridge is then balanced and the reactances are thus compared on the potentiometer scale.

This is a simple unit—but it has proven to be a very useful one, to me.

LOWELL SLACK

## SECOND PRIZE—\$5.00

**Full-Wave Rectification Without A Power Transformer.** Here is a full-wave rectifier for supplying "B" current to A.C.-D.C. sets, energizing speaker fields, and for supplying high voltage to test apparatus, etc. See Fig. 2.

Because of the full-wave action, less filtering is required than with half-wave circuits. Also, the voltage is slightly higher and the maximum current drain is much greater than with equivalent half-wave circuits.

If the 25Z6 metal tubes are used it can be made very compact.

LOREN SVOBIDA

## HONORABLE MENTION

**A "Short" Tester for the Supreme 35 Tube Tester.** A "short" tester for testing every element of a tube can be very easily added to a Supreme type 35 tester. This tester originally does not have a short indicator that detects small leakages. The neon lamp added to the unit indicates much smaller leakage or shorts between elements. In Fig. 4, showing the tube tester, the simple changes and additional parts are evident. The short-circuit or test switch must be a toggle double-pole double-throw type, to close a circuit at either throw of the toggle. The tester originally has an extra toggle switch which is removed and replaced by a new one of the correct type. The 2-W. neon lamp can be mounted in the cord compartment. In testing tubes for shorts, after having heated them to operating temperature, the toggle switch is thrown to the short-test position and each element button pressed. If no short exists, a flash or no flash of the neon tube results. But if a short is present, the neon tube will glow continuously.

HOMER SCHULZ

## HONORABLE MENTION

**A 120-V. and 32-V. D.C. Generator.** The scheme shown in Fig. 5 is a unit for supplying 120 or 32 V. D.C. for testing radio sets of the D.C. type. A 120-V., 1/4-H.P. compound-wound motor (speed 1,725 r.p.m.-G.E. type SD) is driven at a speed of about 2,600 r.p.m. as a generator—producing an output of

118 V. with a load of 100 W. A 1/4-H.P. A.C. motor is used to drive it.

Any D.C. motor will work for this purpose, but the compound type is best. It should be driven at about 45 per cent over normal speed to develop 120 V. output.

A 4- or 8-mf., 300-V. paper condenser is connected directly across the D.C. output from the generator and a 0.1-mf. to 0.25-mf., 300-V. condenser is connected to each brush and back to the frame.

When using the unit for 115 V. sets, place a fuse in socket No. 1 or No. 2, and a 10- to 25-W., 115-V. lamp in socket No. 3. The radio set (Continued on page 629)

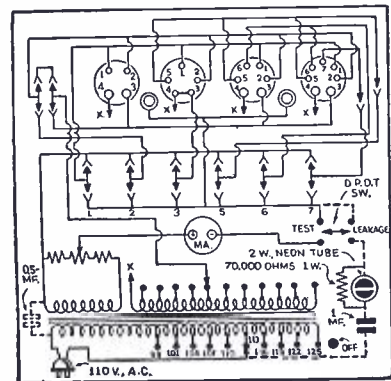

Fig. 4. Neon test for Supreme 35.

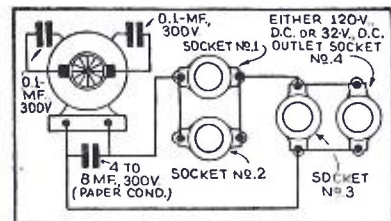

Fig. 5. 120-V. and 32-V. D.C. supply.

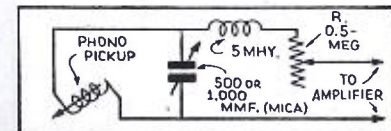

Fig. 6. Phono. pickup coupling unit.

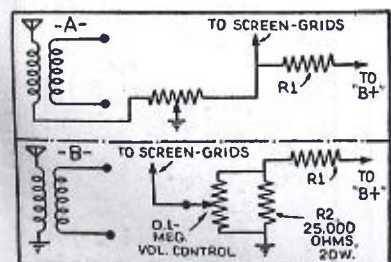

Fig. 7. An improved volume control.

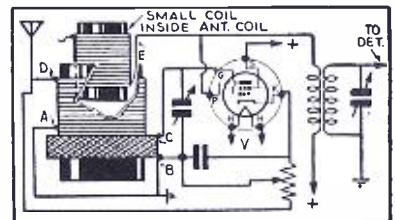

Fig. 8. Increasing the sensitivity.

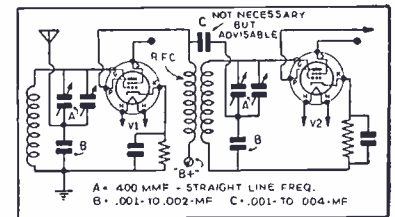

Fig. 9. Capacity coupling scheme.

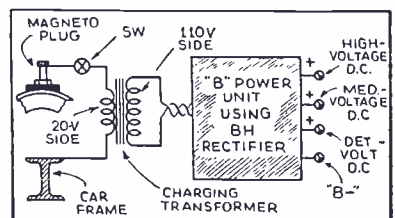

Fig. 10. Magneto-type power unit.

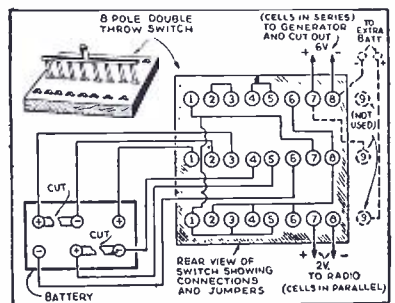

Fig. 11. Wind power for 2-V sets.

## RCA VICTOR MODELS 8BT, 8BT6, 8BK, AND 8BK6

8-tube, battery powered superhet., continuous 3-range (530-1,780 kc., 1,780-6,300 kc., 6.3-22 mc., phonograph connections, "B" battery or vibrator unit.

Table models 8BT, 8BT6, have 8-in. speaker; console models 8BK, 8BK 6, 12-in. speaker, permanent-magnet types. (The "6" indicates use of 6-V. storage battery, operating 135-V. vibrator-type power unit; shown in diagram below.) The 6-V models have a pilot-lamp switch, to turn off lamps and save current. Current drain, 580-640 ma. on 2 V. battery; 1.35A. on 6 V. battery; 19 ma. plate current at 135 V. Tuning dial has 2 ratios; 10:1 and 50:1. Four bias cells, used for the R.F. and I.F. amplifiers, should never be tested with a voltmeter; but a 4-V. battery may be substituted, and comparative plate current readings made. A 40 per cent increase in plate

current indicates a drop of 25 per cent in bias, and bias cells should be replaced.

The range selector switch functions by shorting out unused portion of the inductances in the antenna and oscillator circuits; 1st-det. V1 feeds a 2-stage I.F. amplifier in which magnetite-cored transformers are used, as well as in the 460 kc. wavetrap. The I.F. adjustment is so made that 2 kc. up or down in the 460-ke. test input signal makes little difference; the R.F. adjustments are sharply peaked. A cathode-ray oscilloscope is recommended for alignment; lacking it, a neon-glow indicator across the voice coil. The photo of one model, shown, will aid identification.

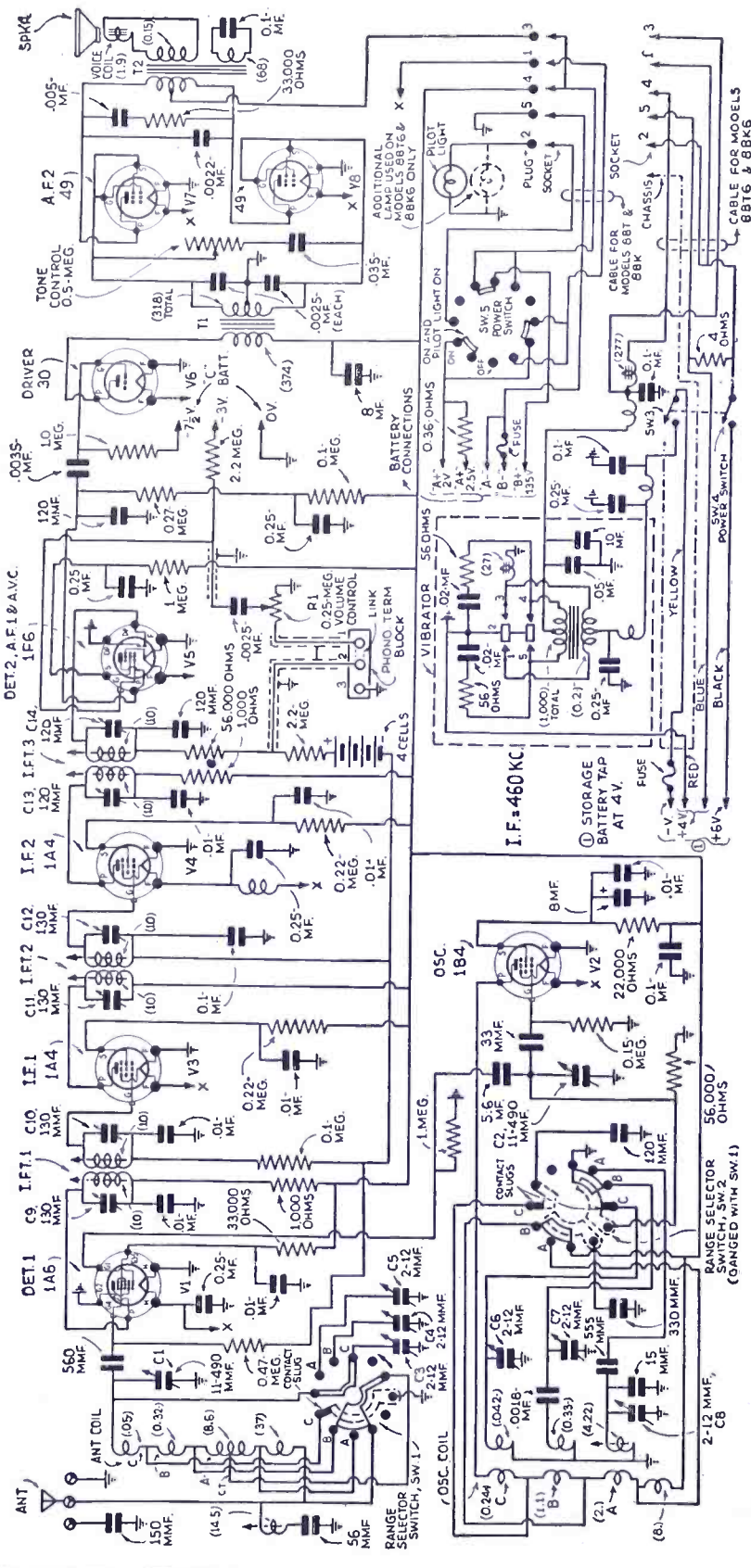
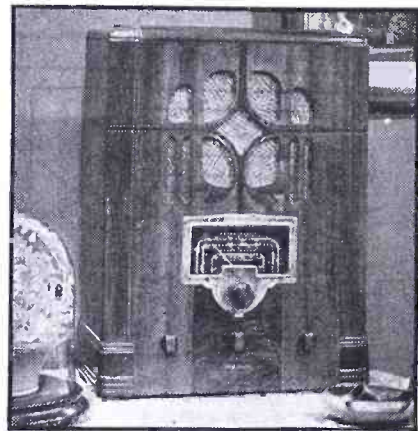

Adjustments of I.F. transformers are made by screws attached to the cores; begin with C14 and C13; then C12 and C11; then C10 and C9. With the oscilloscope, a perfectly symmetrical curve is developed, with maximum amplitude; with glow-lamp or meter, maximum output on 460 kc. signal. R.F. circuits are first compensated at 20 mc., by C6 at minimum capacity peak (plunger near out) and C3 at maximum capacity peak (plunger near in), checking image-frequency at 19.08 mc.; then at 6 mc., by C7 and C4. Wavetrap is then set for minimum signal with 460 kc. test input. Broadcast band settings are made first at 600 kc., adjusting screw L in top of oscillator coil for maximum; then trim C8 and C5 for maximum. Then at 600 kc., screw L is readjusted while rocking tuning condenser through signal, and finally C8 and C5 again. Lock-nuts are to be tightened after each trimmer setting is found.

In vibrator models, red and blue 4-V. leads should not touch; or vibrator buzz may be heard.

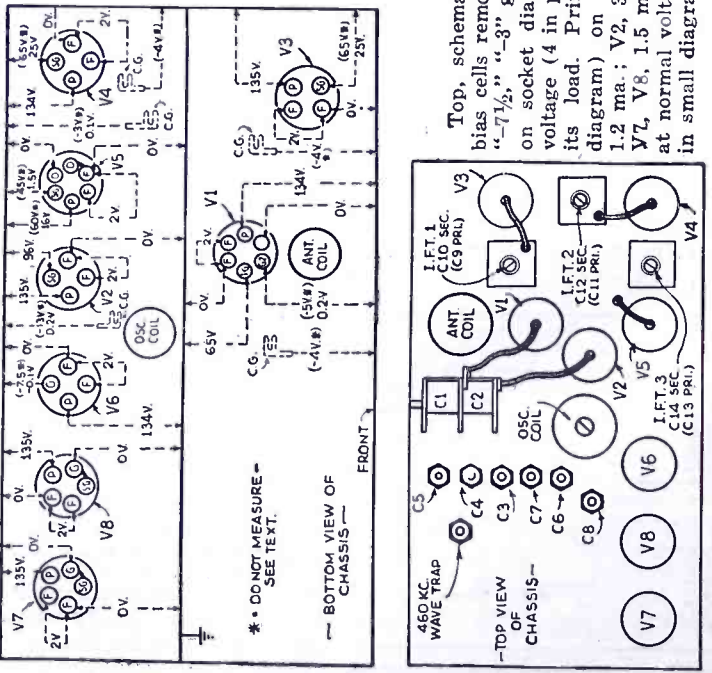
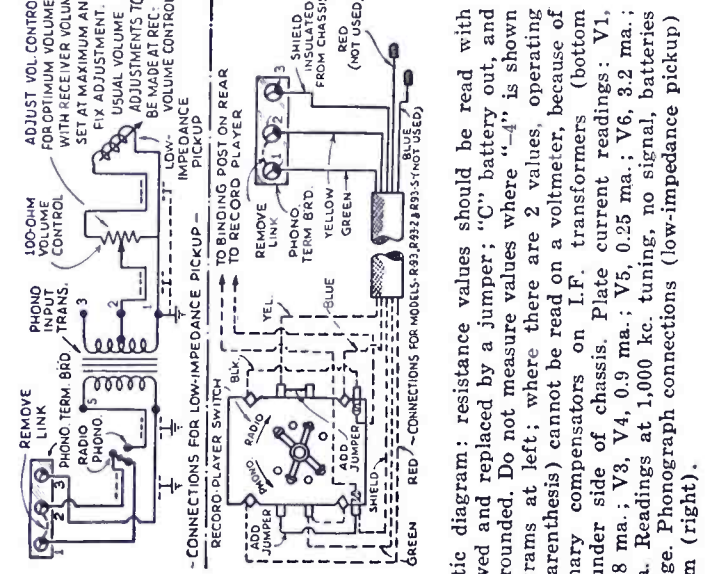

Top, schematic diagram: resistance values should be read with bias cells removed and replaced by a jumper; "C" battery out, and "-1 1/2," "-3" grounded. Do not measure values where "-4" is shown on socket diagrams at left; where there are 2 values, operating voltage (4 in parenthesis) cannot be read on a voltmeter, because of its load. Primary compensators on I.F. transformers (bottom diagram) on under side of chassis. Plate current readings: V1, 1.2 ma.; V2, 3.8 ma.; V3, V4, 0.9 ma.; V5, 0.25 ma.; V6, 3.2 ma.; V7, V8, 1.5 ma. Readings at 1,000 kc. tuning, no signal, batteries at normal voltage. Phonograph connections (low-impedance pickup) in small diagram (right).

**RCA ALL  
THE WAY**

# RCA Radio News

RCA Manufacturing Company, Inc. • Camden, New Jersey  
A Service of the Radio Corporation of America

**EVERYTHING IN  
RADIO-MICROPHONE  
TO LOUDSPEAKER**

To the consumer, RCA means high quality performance at low cost . . . To the radio man, RCA means easier selling, higher profits

## NEW STREAMLINED "MIKE"!

RCA "Aerodynamic" Microphone combines small size with fine performance!



### SPECIFICATIONS:

Type . . . Pressure Operated.  
Frequency Range . . . 100 to 6000 cycles.  
Impedance . . . 250 ohms.  
Average Operating Level -68 db (10 bar signal across open circuit).  
Dimensions . . . 2 5/8" wide, 3" high, 3 3/8" deep.  
Net weight . . . 1 1/4 pounds.  
Finish . . . polished chromium.  
Cable . . . 6 feet shielded cable.  
Stand Fitting Size . . . 1/8" pipe thread.

RCA's new Aerodynamic Microphone, MI-6226—the pressure operated dynamic type—is small enough to fit the hand, light enough to carry easily, and offers outstanding perform-

ance! It is ideal for normal public address work and particularly suited for close talking.

This new "mike", handsomely streamlined, gives excellent frequency response, insuring truly natural tone reproduction and clarity of speech. Its new Alnico permanent metal magnet provides maximum sensitivity and extra long magnet life. In addition, it makes the use of external excitation or power unnecessary.

Besides these features, the RCA Aerodynamic Microphone also offers many others, listed below for your convenience. Look them over. They'll convince you that there's plenty of microphone quality packed beneath the attractive chrome covering!

### NOTE THESE FEATURES!

- Small size • Light Weight • High Sensitivity • No external excitation of power supply required • Rugged construction—insensitive to mechanical vibration.
- Unaffected by changes in temperature, humidity or barometric pressure • May be operated at distances up to 1000 feet from amplifier • Excellent for close talking • Practically non-directional when faced vertically • Minimum response to wind • New Alnico metal magnet—retains magnetism indefinitely.

List Price, \$26.50

### Convert Your Radio Into Phonograph-Radio at Low Cost!

You can do it with the smart RCA Victor Record Player illustrated here! This fine instrument easily and quickly attaches to any electrically operated radio and in a jiffy turns it into an electric phonograph-radio combination! With it, you can hear all your favorite radio programs PLUS recorded music!

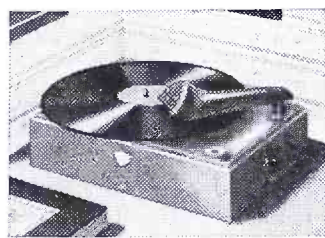

Its small size means you can conveniently place it in any small place. And it's yours for less than \$20, in a fine walnut finish. Or you can get it in red, black or ivory for just a few dollars more.

RCA Victor also offers great values in new, 1937 radios! There are many new models and prices, plus a fine array of performance features including Magic Voice, Magic Brain, Magic Eye, Metal Tubes. And in addition—with an RCA Victor set you enjoy the extras of radio that's RCA ALL THE WAY—instruments created by the same men who build big broadcasting studios! Hear these new radios today. Their beautiful cabinets will more than please you. Easy C. I. T. time payments.

**LATE NEWS FLASH!**  
**1936 RCA Metal Tubes Sales**  
**Double Those of 1935!**

Extra quality of RCA Tubes boosted 1936 sales to double the millions sold in 1935.

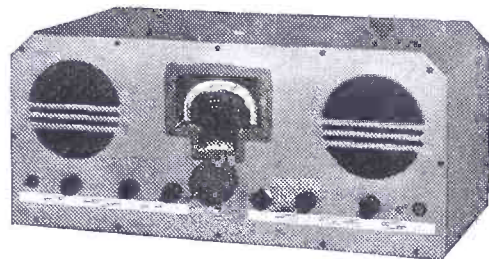

**ACR-155 . . . New, Low-Cost General Purpose Communications Receiver**  
Amateur's Net \$74.50 f.o.b. factory

### 2 RCA Amateur Receivers Answer Price and Performance Problems!

This receiver brings superior performance under modern operating conditions—yet sells at exceptionally modest cost! A number of its features are not to be found in other receivers costing so little. The outstanding features include continuous frequency coverage from 520 to 22,000 kcs...9 Metal RCA Radiotrons for improved high-frequency performance... improved, large tuning knob with crank handle for easy tuning...100 to 1 band spread tuning drive...improved, adjustable, air-dielectric trimming capacitors...magnetite-core i-f transformers...calibration-spread dial for accurate logging... electrically stabilized oscillators.

**ACR-175 . . . New, Multi-Feature Communications Receiver . . . An Outstanding Value!**

Amateur's Net \$119.50 f.o.b. factory

This excellent instrument presents a combination of advanced features not even found in

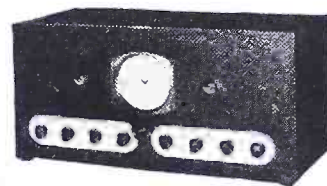

receivers selling at much higher prices!

Its keen selectivity, plus a specially designed crystal filter, makes separation of interfering stations easy—even in the most crowded amateur bands.

Among its 32 performance features is an unusual tuning range—500 to 60,000 kcs.—giving coverage of many services unreached by other communications receivers. Has 11 tubes, two stages of high-gain i-f amplification and a smooth-handling, single control band spread system for easy tuning and accurate logging without use of reference points.

Please Say That You Saw It in RADIO-CRAFT

# I'LL PROVE IT!..

...JUST **17¢** A DAY  
CAN PREPARE YOU FOR A  
**GOOD-PAYING  
JOB IN RADIO!**

Sprayberry Training does much more than teach you all branches of Radio, Television, Electronics, Sound, etc. It teaches you modern business methods—helps you make spare time profits **WHILE YOU LEARN**—sets you up for an actual start in a good, money-making profession—backs up every step of your training with **PROFESSIONAL RADIO EQUIPMENT!**



... Learn how the **Most SUCCESSFUL Home Training Plan in Radio ACTUALLY SETS YOU UP FOR BUSINESS in an Industry that is Providing Fortunes for Wide-Awake Men** . . . .



**ANY OF THESE FASCINATING JOBS MAY BE YOURS!**

Don't wish for a good-paying job. **TRAIN FOR ONE NOW!** The quality of Sprayberry training is clearly shown by the outstanding success of my students throughout the country—and by the strong words of praise from outstanding leaders of the great Radio Industry. Send the coupon today for our new catalog. **GET THE FACTS!**

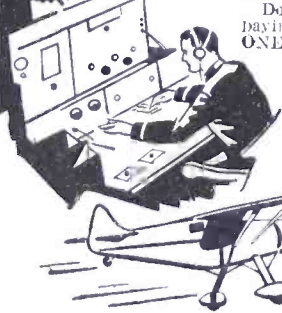

**I ACTUALLY SET YOU UP READY FOR BUSINESS**

No matter what kind of Radio Training you take, it is **ABSOLUTELY NECESSARY** that you have professional equipment of the kind I supply. Before you're ready to start making **REAL MONEY**, I teach you to use it under actual working conditions. That's why Sprayberry training is so easy to learn at home—why many students make extra money on Radio work almost as soon as they start—and why, upon graduation, they are ready to enter business **AT ONCE** for full or part time profits.



F. L. Sprayberry

**THE MOST IMPORTANT COUPON YOU'LL EVER CLIP**

## SPRAYBERRY ACADEMY OF RADIO

F. L. Sprayberry, President  
2545 University Place, N. W. Washington, D. C.  
Without obligation on my part, please send your Free Book, "MY FUTURE IN RADIO," and other details of famous Sprayberry Training.

Name .....

Address .....

..... RC 4/37  
PASTE COUPON ON PENNY POSTCARD AND MAIL TODAY

## INTERNATIONAL RADIO REVIEW

(Continued from page 594)

From *Practical and Amateur Wireless* (London).

### PERMANENT-MAGNET SPEAKER

**A**LTHOUGH the device shown in Fig. B appears to be a searchlight, it is actually a new public-address loudspeaker available in England!

The reproducer is a permanent-magnet dynamic type having a 12-in. cone and an extra-large voice coil. A permanent magnet of high-flux density supplies the field excitation. The entire speaker is enclosed in a weather-proof metal case which serves to focus the sound in one general direction and also acts as a baffle.

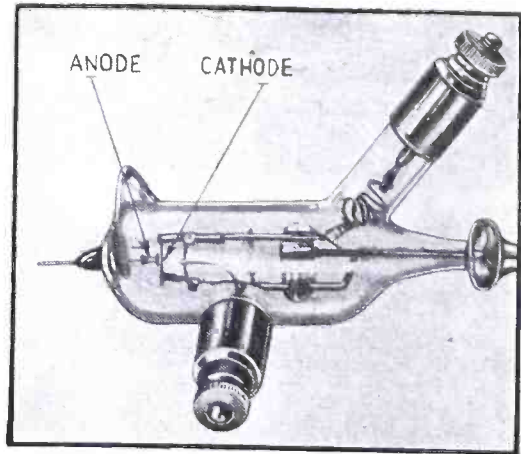

Detail of the diode V-T. Voltmeter elements.

### A.F.C. IMPROVEMENT

**A**SERIOUS limitation of the automatic-frequency-control systems now in use is the fact that they are not equally effective on all wavelengths, since the control tubes directly affect the oscillator frequency and the amount of correction thus varies at different points of the frequency band.

A means of removing this drawback was recently described in *Wireless World* (London). The ordinary superhet. frequency converter is replaced by a circuit containing two frequency changers so that for all wavelengths within the tuning range the second intermediate frequency remains constant. As shown in Fig. 2, the first converter, V1, feeds a second converter, V2, the output of the latter being fed to the double-diode tube, V5. The two circuits A and B are tuned one above and the other below the second intermediate frequency. Any initial mistuning thus produces an E.M.F. across the 2 balanced load resistances R1 and R2. This potential is applied to a control tube, V4, which is shunted across the tuning condenser, C, of the oscillator circuit of the second converter. The resulting change in the effective grid-cathode capacity of V4 provides the correcting factor which brings the set accurately in tune.

### NEW LABORATORY TUBES

**T**WO ELECTRONIC tubes which have interesting applications in laboratory development and experimental work are shown in Fig. C. The first (at A) is a diode-type vacuum-tube voltmeter tube which was designed by Manfred von Ardenne, in Germany, for measurements in the decimeter (extremely high) range of frequencies.

Measurements with ordinary tubes at these high frequencies are prevented by an effect called the "electron-transit-time" which is due to the spacing between the cathode and plate of these tubes.

The new tube is equipped with a cathode supported at the end of a long glass tube which has 3 glass bulbs sealed in. These glass bulbs (called "glass springs") allow the cathode to be moved closer than its normal spacing from the plate by means of a micrometer screw in the tube support, which compresses the glass bulbs. From *Radio-Centrum* (Hague-Netherlands).

The second laboratory tube is a composite type, combining the electrometer-type triode tube, which was described some time ago on this page, with a standard photocell and having an internal grid-coupling resistor.

This tube has the high input (grid to cathode) impedance which is very much higher than ordinary tubes, being well over 100 megs. at 1,500 kc. This reduces the current drain of the device to an absolute minimum so that it can be used as an electrometer to replace the usual gold-leaf type in the measurement of minute currents. The internal photocell permits specialized measurements such as accurate photometry of lamps, the measurement of glass electrode potentials in the determination of hydrogen-ion concentration, the measurement of high resistances, and the study of piezoelectric effects in crystals. From *Wireless World* (London).

### PE. ESCALATOR CONTROL

**A**N INTERESTING application of photoelectric control was recently disclosed in connection with the metropolitan (subway) railway in Paris (France).

A number of escalators were installed at the stations of this railway and these moving stairways are started in operation by the interception of a beam of infra-red light by passengers leaving the station platform. The escalator is so adjusted that when the last passenger has been carried to the upper level, it stops. See Fig. 3.

### A MOTION-PICTURE RECORDER AND OSCILLOSCOPE

**A** NEAT and useful combination of laboratory oscilloscope and recording motion-picture camera is shown in Fig. D. This is a product of the German Siemens Co. and was described in a recent issue of *Siemens Zeitschrift* (Berlin).

The oscilloscope is equipped with a "fast" tube and the circuit is arranged in such a way that the voltage applied to the horizontal plates is varied in synchronism with the shutter of the motion picture camera.

How do you like this department? Let us know, please, whether this effort on our part to acquaint you with the outstanding monthly European radio developments meets with your approval.—Editor

## WHAT ABOUT RADIO IN 1937?

(Continued from page 585)

### POWEL CROSLY, JR.—

for 1936 will have reached 1,600,000 to 1,750,000 units compared with 1,200,000 auto-radio receivers sold in 1935. Radio, itself, has been one of the most important factors in business recovery. Aside from being a \$400,000,000-a-year industry, radio broadcasting, a \$100,000,000 industry in itself, has been a vital factor in business recovery in two ways; one, as a most effective advertising medium and the other as the quickest means of business, financial and news reporting.

(2) Unquestionably the radio industry as well as industry in general faces a great growth in the future. Greater purchasing power of the people, together with the fact that there is an increasing appreciation of better radio sets, assures that.

(3) The radio industry may be compared with other industries in the opportunities it presents to those who keep pace with its new development and growth. In fact, it is necessary for

any business to keep pace with progress if it is to endure. The opportunities in radio today are no doubt greater than they have ever been. Of course, keep in mind the difference between a pioneering era and one more fully developed.

(4) I would say that radio and its many branches offer a young man as many opportunities as any other business.

(5) This is an age of trained men and with specialization becoming more and more the rule, competently-trained men will be required more than ever before.

(6) This is a question that would require much space to answer. As a general suggestion, a young man desiring to enter the radio business, or any other, should prepare himself with a good fundamental education. Then, depending on where he lives, endeavor to secure a position with a dealer, distributor, or manufacturer of either radio receivers or parts, or a broadcasting station. In this the young man's own ambition and industry will be of great value. There is no magic formula.

Please Say That You Saw It in RADIO-CRAFT



## WHAT ABOUT RADIO IN 1937?

(Continued from page 585)

### ISIDOR GOLDBERG—

factory workers, broadcast station personnel, and engineers is increasing and will continue to increase. There are opportunities for many new men of various kinds of training.

(4) Yes. There is every reason for a young man to look forward to a permanent future in the branch of the industry to which his talents are suited.

(5) Radio is a technical product, and performs technical functions which will always require the services of technically-trained men.

(6) Try to find out which branch of the industry appeals to your individual ability. Then get the best training possible for that kind of work.

### WESLEY M. ANGLE—

Pres., Stromberg-Carlson Telephone Mfg. Co.

(1) Most certainly the radio industry is benefiting, and will continue to benefit by the general improvement in business conditions throughout the country.

(2) I am doubtful that the industry faces greater growth ahead than has been experienced to date. I do not at all feel that the saturation point has been reached because there will be many more kinds of homes, equipped with one set, which will be equipped with 2 or 3, and there are still persons who have no sets who will have them, to say nothing of the general growth in population. But, to a large extent, radio has now reached the condition where sets are sold to replace sets already in use, and modern sets should not need replacements as quickly as did sets in the days when a major improvement was being introduced every year.

(3) Most certainly I feel the radio industry still offers opportunity to those who keep pace with its new developments and growth.

(4) We feel the industry offers a good opportunity for young men as a permanent career. Of course we manufacturers had to reduce our forces tremendously during the depression years. Ours was cut to one-sixth or one-seventh of its former size, the persons laid off being released from all departments (manufacturing, engineering, selling and accounting). And for sometime after the up-grade began, it was a question of bringing back persons already laid off and not of hiring young men who had never worked for us before. This past year both manufacturers and dealers have been hiring a considerable number of young men who were not previously employed by them, and this year there will continue to be openings for young men from time to time in all lines of the industry.

(5) If there are going to be openings for young men of all types, there will certainly be openings for one who is competently trained.

(6) I can only answer question No. 6 in very general terms because the answer depends so much on the ability, previous training and inclinations of the young man in whose behalf you were asking the question. Every young man who wishes to enter the industry should acquire as much education as he can along the lines of the particular branch of industry in which he is most interested, with due regard to his own native ability, and yet with the realization that some cultural education as well as technical education is desirable.

## HOW TO USE V.-T. VOLT-METERS IN RADIO AND P.A. SERVICING

(Continued from page 601)

load.

Part III, in June *Radio-Craft*, will conclude this series of articles on the V.-T. voltmeter, with a consideration of D.C. voltage measurements.

The descriptions of measurements of r.m.s. and peak A.C. voltages will give the Service Man an idea of the flexibility and usefulness of vacuum-tube type meters for service work. The high sensitivity (in other words, low current drain in the meter) permits many measurements which cannot be made by the usual d'Arsonval, moving vane, and thermocouple or hot-wire instruments.

This article has been prepared from data supplied by courtesy of Clough-Brengle Co.

## Mr. Service Man..

*Earn*  
WHILE YOU PAY

Buy New  
Test Equipment  
on Wards MONTHLY PAYMENT PLAN

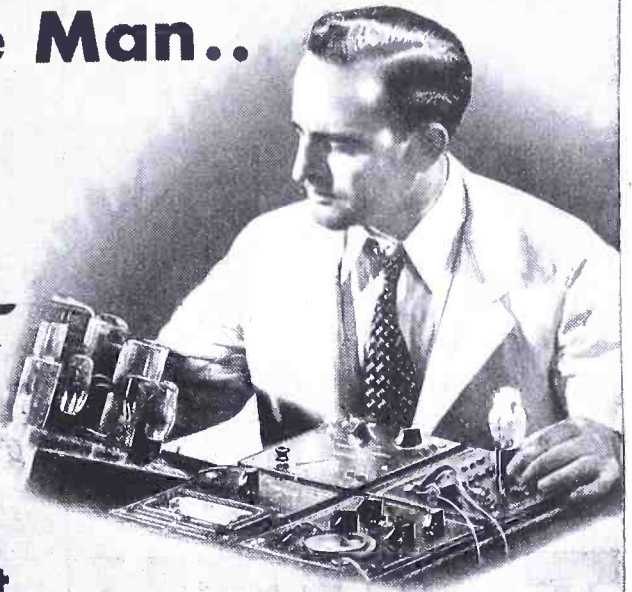

"Nothing breeds success like success" . . . and in the Radio Service business your success depends upon your ability to give speedier, more efficient service to your customers. You can't do it with old, obsolete equipment. You need the best, most up-to-date instruments and supplies that the market can offer.

And that's where Wards can help you. Wards new 1937 Radio Catalog offers you a complete line of the finest, most modern testing equipment . . . books that explain today's servicing problems . . . countless other service supplies—in addition to America's finest line of PA systems. ALL these may be bought on Wards Convenient Monthly Payment Plan, enabling you to buy what you need TODAY, and pay for it while using it.

Wards prices are always surprisingly low. Yet it is often inconvenient to pay cash or inadvisable to disturb working capital. Wards Monthly Payment Plan aids you in getting that business-building equipment into your shop NOW, so it can be working for you, increasing your profits while you are paying for it. You pay just a small amount down, and the balance in monthly payments. Terms for \$10 orders are only \$2 down, \$2 monthly with a small carrying charge.

Don't put off investigating this convenient buying plan any longer. Fill out the coupon TODAY for your copy of Wards 1937 Radio Catalog!

## MONTGOMERY WARD

Largest Distributors of Sound Systems in U. S.

CHICAGO • BALTIMORE • ALBANY • KANSAS CITY  
ST. PAUL • DENVER • PORTLAND • OAKLAND • FT. WORTH

Terms As Low  
As \$2 Down  
\$2 Monthly

•  
TRIPLETT  
READRITE  
RANGER  
RCA  
WESTON  
HICKOK  
MILLION  
SOLAR  
MONARCH  
SIMPSON  
TOBE  
TRIUMPH  
CLOUGH-  
BREngle  
SUPREME

Assure yourself of a copy by mailing coupon to nearest Ward House TODAY.  
MONTGOMERY WARD, Dept. RZ-2

Yes, I want your new 1937 Radio Catalog with details on Monthly Payment Plan.

Name.....

Street or Box Number.....

City..... State.....

Please Say That You Saw It in RADIO-CRAFT



WIN A SOUND TRUCK OR \$600 CASH!

Also 500 OTHER PRIZES!

It's the easiest contest ever! Just answer a simple question - an answer that every Serviceman gives to his customers two or three times a week. It may win for you a new V-8 service truck with a complete built-in sound system - or \$600 Cash! That's the first prize. There are 500 other prizes you will find equally desirable! Learn about the Raytheon Contest today!

ASK YOUR JOBBER!



RAYTHEON PRODUCTION CORPORATION
420 Lexington Ave. New York, N. Y.
55 Chapel Street Newton, Mass.
445 Lake Shore Drive Chicago, Illinois
555 Howard Street San Francisco, Cal.
415 Peachtree St., N. E. Atlanta, Ga.

RAYTHEON IS THE MOST COMPLETE LINE-ALL TYPES OF GLASS, OCTAL BASE, METAL, RESISTANCE AND AMATEUR TRANSMITTER TUBES.

TECHNICIANS' DATA SERVICE

JOSEPH CALCATERRA

DIRECTOR

A special arrangement between RADIO-CRAFT magazine and the publishers of this literature, which permits bulk mailings to interested RADIO-CRAFT readers, eliminates the trouble and expense of writing to each individual organization represented in this department.

2. HAMMARLUND CATALOG. Contains complete specifications, illustrations and prices on the Hammarlund line of variable and adjustable condensers; intermediate frequency transformers, coils and coil forms; shields; chokes and miscellaneous parts for broadcast, short wave and ultra-short wave reception and transmission. Also contains description and prices of the Hammarlund line of "Comet Pro" and "Super Pro" receivers.

5. ELECTRAD 1936 VOLUME CONTROL AND RESISTOR CATALOG. Contains 12 pages of data on Electrad standard and replacement volume controls. Truvolt adjustable resistors, vitreous wire-wound fixed and adjustable resistors and voltage dividers, precision wire-wound non-inductive resistors, center-tapped filament resistors, high-quality attenuators, power (50- and 150-watt) rheostats and other Electrad resistor specialties.

29. THE KEY TO SUCCESSFUL SERVICING. Four different types of combinations of courses on Radio Servicing, Public Address Work, and Television, developed by the Radio Service Institute, are described in this 24-page booklet. Complete information, including outlines of the courses and costs, is given. Two of the courses are designed for the more advanced and more ambitious Service Men who are anxious to get to the top of their profession. The other two courses are for less-experienced Service Men who want to advance more rapidly in the Radio Servicing Field. Please do not ask for this booklet unless you are interested in taking a course in these subjects.

53. POLYIRON COIL DATA SHEET 536. This folder contains complete catalog descriptions, specifications, prices, performance curves and circuits showing applications of the complete line of Polyiron radio components made by the Aladdin Radio Industries, Inc.

57. RIBBON MICROPHONES AND HOW TO USE THEM. Describes the principles and operating characteristics of the Amperite velocity microphones. Also gives a diagram of an excellent humless A.C. and battery-operated preamplifier.

65. THE 1937 LINE OF SUPREME TESTING INSTRUMENTS. This 24-page catalog gives complete information on the entire Supreme line of testing instruments, including the Model 585 Diagonometer; the Model 540 and 550 Radio Testers; the Model 500 Automatic; the Model 505 Tube Tester; the Model 555 Diagonoscope and other Supreme oscilloscopes, tube testers, signal generators and multimeters. Complete details of the Supreme Easy Payment Plan for purchasing testing equipment on the installment plan are also given.

66. SUPREME DESIGN MANUAL "A" OF TUBE AND RADIO TESTING CIRCUITS. This interesting and useful 60-page handbook covers the fundamental principles of meters, measuring instruments and test circuits and illustrates, with detailed explanations, the basic circuits used in Supreme Testing Instruments. Every Service Man who is interested in the "why" of testing circuits should have a copy of this handbook in his kit.

73. HOW TO ELIMINATE RADIO INTERFERENCE. A handy folder which gives very complete information on how to determine and locate the sources of radio noise by means of the Sprague Interference Analyzer. A description of the analyzer and method of using it is included, to-

Radio-Craft Technicians' Data Service
99 Hudson Street,
New York City, N. Y. RC-437

Please send to me, without charge or obligation, the catalog, booklets, etc. the numbers of which I have circled below.

2 5 29 53 57 65 73
74 75 76

My radio connection is checked below:

- ( ) Service Man operating own business.
( ) Service Man for manufacturer.
( ) Service Man for jobber.
( ) Service Man for dealer.
( ) Service Man for servicing company.
( ) Dealer.
( ) Jobber.
( ) Experimenter.
( ) Professional Set Builder.
( ) Amateur Set Builder.
( ) Short Wave Work.
( ) Licensed Amateur.
( ) Station Operator.
( ) Radio Engineer.
( ) Laboratory Technician.
( ) Public Address Worker.
( ) Manufacturer's Executive.
( ) Student.

I am a:
( ) Subscriber ( ) Newsstand reader
I buy approximately \$..... of radio material a month. (Please answer without exaggeration or not at all.)

Name .....

Address .....

City ..... State .....
(Please print name and address)

Avoid delay. The catalogs and booklets listed are now in stock and will be sent promptly as long as the supply lasts. Please use this coupon in ordering. The use of a letter causes delay.

gether with data on how to eliminate interference of various kinds once the source is located.

74. SPRAGUE 1936 ELECTROLYTIC AND PAPER CONDENSER CATALOG. Gives specifications, with list and net prices on a complete line of wet and dry electrolytic, and paper condensers made by the Sprague Products Co. for radio Service Men, set builders, experimenters and engineers. Information on the Sprague Capacity Indicator, for making capacity tests on condensers and in servicing receivers, is included.

75. SPRAGUE TEL-U-HOW CONDENSER GUIDE. A valuable chart, compiled by the Sprague Products Co. which tells the proper types, capacity values and voltages of condensers required in the various circuits of radio receivers and amplifiers, and how to locate radio troubles due to defective condensers. Includes data on condenser calculations.

76. FACTS YOU SHOULD KNOW ABOUT CONDENSERS. A folder, prepared by the Sprague Products Co., which explains the importance of various characteristics of condensers, such as power-factor, leakage, capacity and voltage in determining the efficiency or suitability of a given condenser to provide maximum filtering and safety in operation.

OPERATING NOTES

(Continued from page 606)

section in these models has been removed by making a direct connection from the ground side of the amplifier to the ground of the power converter. Sharper tuning has also resulted from this alteration. (Fig. 1H.)

The original ground connection between the sections of this and other Sparton models, consists of a piece of tin which lies on the baseboard with the tuner, R.F. amplifier and power converter sections merely resting on it, there

being no soldered connections made. See Fig. 1I.

Noise caused by poor contact at one of these points can be eliminated by providing a wire connection between the chassis for tuner and power supply. The piece of tin can be left in place under the two chassis, if desired. The wire should be soldered to lugs, fastened under screws on the chassis.

A. F. PATSCHECK

Please Say That You Saw It in RADIO-CRAFT

## PRACTICAL RESISTANCE AND CAPACITY DECADE BOXES

(Continued from page 607)

choosing 16 resistors between 100 ohms and 600,000 ohms (0.6-meg.) and grouping them with each of the 4 switches, values can be read between 100 and 999,900 ohms (0.9999-meg.) in steps of 100 ohms.

Each section of the resistance decade box consists of a 2-gang, 10-position selector switch and 4 resistors. By one method of wiring a single decade section could be assembled as shown in Fig. 1A. This employs a conventional 2-gang, 2-pole, 10-position switch. This method requires much external wiring, entailing additional labor and a possibility for poor connections, so a better plan was figured out.

Special switch sections were designed. These are shown, in Fig. 1B, with the resistors numbered and connected to the proper terminals. Note the absence of external connections. By using specially-designed contact clips and rotors all of the connections are automatically made as the switch is rotated. The resistance is measured between points A and B. A completely-assembled decade switch section is shown in Fig. A, the heading photograph.

To go from 100 ohms to 999,900 ohms in steps of 100 ohms, use the following resistor groupings:

Resistor Number	Sw.1 Ohms	Sw.2 Ohms	Sw.3 Ohms	Sw.4 Ohms
1	100	1,000	10,000	100,000
2	200	2,000	20,000	200,000
3	300	3,000	30,000	300,000
6	600	6,000	60,000	600,000
	Hundred (1-9)	Thousand (1-9)	Thousand (10-90)	Thousand (100-900)

Since resistance is being considered, it is only necessary to wire these 4 sections individually and then place the 4 separate units in series. If higher ranges are required, add switches in series. The range is only limited by the commercial values of available resistors.

### DECADE CONDENSER UNIT

Just as for the resistance decade, the condenser decade box consists of 4 individual units, each made up of 1 switch and 4 condensers.

The problem is slightly different, however, since condensers must be placed in parallel to add two or more values together. One circuit to accomplish this is shown in Fig. 2A. Here a 4-gang, 4-pole, 11-position switch is used. It is shown here to illustrate how the condensers are connected in parallel but, due to the unused terminals on 3 of the sections, could hardly be called economical.

By proper design, a special 1-section switch is available that accomplishes all that the 4-gang switch shown in Fig. 2A can do. All external connections except the actual connection of the condensers are eliminated. This switch, viewed from the rear, is shown at Fig. 2B. The capacity is measured from A to B. Just as for the resistance-decade switch, the condenser numbers when multiplied or divided by 10,000, 1,000, etc., indicate the range that a given switch will cover. This tabulation illustrates the range of a typical 4-section condenser decade box:

Condenser	Sw.1 mf.	Sw.2 mf.	Sw.3 mf.	Sw.4 mf.
1	0.0001	0.001	0.01	0.1
2	0.0002	0.002	0.02	0.2
3	0.0003	0.003	0.03	0.3
4	0.0004	0.004	0.04	0.4
(0.0001-0.001)	(0.001-0.01)	(0.01-0.1)	(0.1-1.0)	

This assortment gives an available range from 0.0001-mf. (100 mmf.) to 1. mf. in steps of 0.0001-mf. (100 mmf.), or 10,000 distinct capacity values! In increasing the range of condenser decade boxes, be sure to add additional sections in parallel—not in series, as is the case for resistors. This, of course, is a fundamental difference between condensers and resistors.

The switches described above are available in knocked-down form.

### LIST OF PARTS

#### Resistor decade switch

- One Centralab K-121 Index assembly;
  - One Centralab Type N switch section;
  - One Centralab Type P switch section;
- #### Condenser decade switch
- One Centralab K-121 Index;
  - One Centralab Type Q switch section;
  - Two Centralab K-117 dial plates.

This article has been prepared from data supplied by courtesy of Centralab.

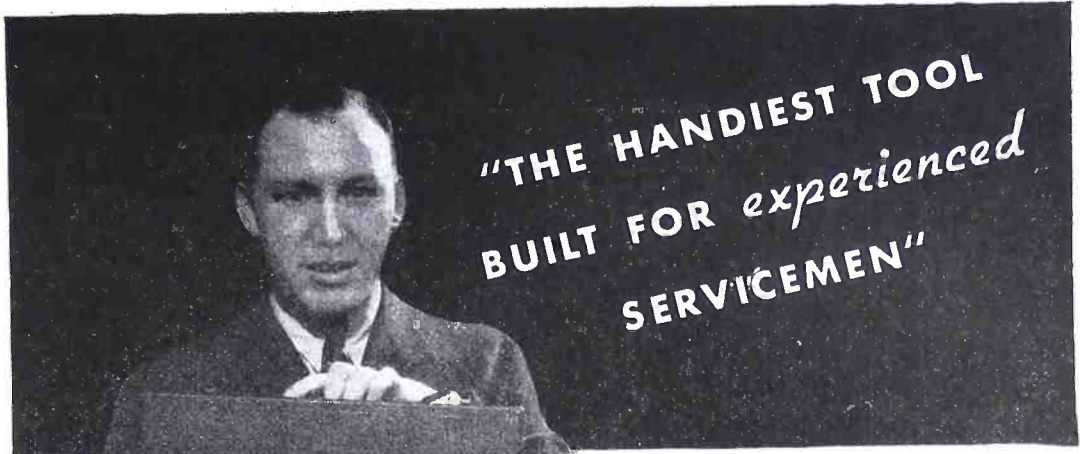

"THE HANDIEST TOOL  
BUILT FOR experienced  
SERVICEMEN"

## THE WESTON CHECKMASTER

\$45<sup>00</sup>  
NET

TO DEALERS IN U. S. A.

It's the experienced servicemen who have gone for the Model 771 Checkmaster in a big way. This was to be expected . . . for we built Model 771 to give the serviceman everything he needs for trouble shooting and estimating in one compact, easy-to-carry case. He has all this in the Checkmaster . . . providing as it does for a thorough check of tubes, as well as for checking continuity, resistances and voltages. In addition, it has a spare compartment for tubes or tools. This means time saved in answering emergency calls . . . for he need carry only this one, compact and complete Checkmaster for quickly getting at the root of the trouble.

But to make the Checkmaster even more useful, it has been strikingly designed and finished for counter use as well . . . making it the handiest, most versatile tool any serviceman can own. Inexpensive, too. And the name it bears is the best guarantee of instrument dependability and long life. Be sure to see the Checkmaster at your jobber's, or return the coupon for complete information.

### FEATURES:

INGENIOUS WESTON SWITCHING CIRCUIT  
ACCOMMODATES TESTING OF TUBES WITH  
WANDERING FILAMENTS

- Wired for testing latest tubes.
- Neon short check while tubes are hot.
- Cathode leakage test of CORRECT DESIGN.
- Individual tests on elements of diodes.
- Voltage ranges for point-to-point testing.
- High and low resistance ranges for continuity testing with built-in filtered power supply.
- Actual condenser leakage measurements— all types of high and low voltage condensers— read in ohms on meter scales.
- All readings on one legible, open-scale meter . . . the famous WESTON 301 in modern rectangular form.
- Positive line voltage control.



Weston Electrical Instrument Corp., 599 Frelinghuysen Ave., Newark, N. J.

Rush me bulletin on the Checkmaster and other Radio Instruments.

NAME.....  
ADDRESS.....  
CITY.....STATE.....

Please Say That You Saw It in RADIO-CRAFT

# MAKE THE RADIO-CRAFT MIDGET OSCILLOSCOPE

(Continued from page 595)

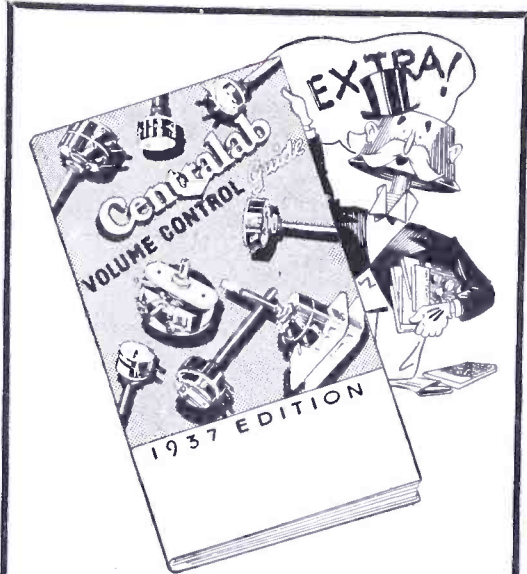

## BIGGER AND BETTER THAN EVER!

83% more pages . . . listing 400 makes and 7000 models . . . up to the minute—including 1936 and early '37 receivers. Shows how a mere handful of standard controls will service most every set—and—for that unusual job, we list special replacement controls.

Sound projection and tone control switch data is generously featured. Often called the "serviceman's bible" . . . it should be on every service bench, and in every service kit.

As usual it is yours for the asking.

Get your new 1937  
**CENTRALAB**  
Volume Control Guide

See Your Jobber for the  
New 1937 Edition

# Centralab

MILWAUKEE WISCONSIN  
BRITISH CENTRALAB, LTD.  
Canterbury Rd., Kilbourn  
London N.W. 6, England  
CENTRALAB  
118 Avenue Ledru-Rollin  
Paris XI, France



## ONLY \$3.45

Positively the most remarkable tool you have ever seen

### A Combination Arc Welder And Trouble Light in One Tool

Buffalo Arc Iron works off of any storage battery and will weld solidly metals, granite and porcelain ware, copper, aluminum, cast iron, steel, etc. Radio men, electricians, inventors, repair shops, factories, farmers, etc., will find thousands of uses for this tool. Can be changed into a trouble light in a few seconds.

Send \$1.00 now, pay postman balance of \$2.45 plus a few cents postage. Positive money-back guarantee in 5 days if you are not completely satisfied.

**GUARANTEED FOR TWO YEARS**  
**BUFFALO SALES CO.**  
Dept. B-4 Kearney, Nebraska

## RADIOS..SAVE UP TO 50%

DEAL DIRECT...FACTORY PRICES! Many models to select from: AC-DC; All-Wave; Farm sets that operate like city radios! Your name and address on postcard brings you NEW Bargain Catalog in colors FREE. Get details of 30-DAY TRIAL plan and agent-seller proposition! GOLDENTONE RADIO CO. Dept. B4, DEARBORN, MICHIGAN

Free Catalog

30 DAY TRIAL \$6.98 UP

## Learn SOUND RECORDING TALKING PICTURE PROJECTION TELEVISION-RADIO

Master training courses qualify you for good jobs. Practical, easy to learn. Newest equipment, 30,000 graduates. Earn room and board while learning. Coach R. R. fare allowed to L. A. Write for FREE BOOK. Address Dept. 4-RC, 4000 S. Figueroa St., NATIONAL SCHOOLS - Los Angeles

zontal amplifier for either 60-cycle or sawtooth sweep, or it may be used to amplify any external input to the horizontal plates. Either amplifier may be cut in or out separately and the amplitude controls for vertical or horizontal plates are available for voltage control whether the amplifiers are in use or not.

An additional control is provided through the use of a single-pole double-throw switch on the potentiometer which controls vertical amplitude. This switch cuts out the potentiometer entirely when the instrument is to be used for transmitter R.F. measurements. The R.F. is no respecter of potentiometers as many hams have found to their sorrow! Even if the control is "on" fully, a great deal of heating occurs and the control is usually ruined; so the best we can do is to cut it out. When the potentiometer is turned fully counterclockwise the switch operates to cut it out. A slight operation must be performed on the resistance element as it is essential that the contact arm be entirely open-circuited when the switch is operated. It is a simple matter to scrape sufficient carbon from the element so that this is accomplished. The "off" position is noted on the diagram.

### SYNCHRONIZING CONTROL

Through the medium of a switch and a potentiometer full synchronization of patterns is easily attained. The switch allows for (1) internal, (2) 60-cycle, or (3) external synchronization. In the latter position a "wobbler" may be connected for use when tuning-up sets or for observing R.F. transformer or amplifier response curves.

It should be noted that this synchronization input circuit is of high impedance, rather than low impedance, as found on most commercial oscilloscopes. If it is imperative to have low-impedance synchronization connections, this may easily be accomplished by use of a transformer with the high-impedance winding connected to the binding posts. A microphone transformer will give a very low-impedance input if this is needed.

### DESCRIPTION OF COMPONENTS

A short description of some of the parts may be in order. While the power transformer is the only really "special" part, the builder is urged to follow the List of Parts as closely as possible, as the units have been selected for special elements of quality and compactness. The transformer, while not made for exactly this circuit, is designed for use with the 913 tube. In our circuit it is slightly overloaded, but, probably due to careful design, there seems to be no overheating, even when the apparatus is used for a considerable length of time. The 2 rectifiers and the heaters of the 6J7s are run from the winding marked "6.3 V.—Y, Y." This is a load of 1.2 A, but as noted it does not seem excessive. The other 6.3 V. winding is rated at 0.6-A. and connects only to the 913 tube. When hooking up the heater be certain that pin No. 2 goes to the junction of the 2 potentiometers. If pin No. 7 is connected in this position all sorts of weird patterns will result. The 2.5 V. winding supplies the type 885 oscillator, and in addition, a 60-ma., 2-V. pilot lamp is connected to this winding. A series resistor of 10 ohms provides the necessary voltage drop. Do not use any other type of pilot light, as the current drain will be too high.

The high-voltage windings deliver about 450 V. and 200 V., and supply the 913 and amplifier circuits respectively. A tap on the high-voltage winding allows the use of about 325 V. on the 913; this gives increased sensitivity but reduced brilliancy and sharpness of focus. The patterns are still very usable, however, and a double-throw switch might be incorporated to change the voltage.

A very desirable feature of the transformer is its apparent complete lack of external field. The 913 almost touches the transformer, yet the latter causes no change of pattern shape! A small replacement transformer tried in a previous model had so much field it could not be used at all.

The bleeder for the low voltage is made partly by a fixed resistor of 2 W. size and partly by a small, wire-wound unit with 2 sliders on it, one for the screen-grid voltage of the amplifiers, and the other for control-grid bias of the 885. The former is set at 30 V. and the latter at about 7 V.

The List of Parts will permit the constructor to proceed to the actual point of assembling the components. Part II in a forthcoming issue will contain constructional instructions.

### LIST OF PARTS

- One Kenyon transformer, type T-207;
- One Kenyon midget A.C.-D.C. choke;
- Two Electrad potentiometers, one with S.P.D.T. switch, 0.5-meg.;
- One Electrad potentiometer, 1 meg.;
- One Electrad potentiometer, 25,000 ohms;
- One Electrad potentiometer with S.P.S.T. switch, 10,000 ohms;
- One Electrad potentiometer, 0.1-meg.;
- One Electrad resistor, 25,000 ohms, 25 W.;
- Two IRC resistors, 2 megs., 1/2-W.;
- One IRC resistor, 5 megs., 1/2-W.;
- One IRC resistor, 25,000 ohms, 1/2-W.;
- One IRC resistor, 1,000 ohms, 1/2-W.;
- Two IRC resistors, 3,000 ohms, 1/2-W.;
- One IRC resistor, 0.5-meg., 1/2-W.;
- Two IRC resistors, 0.25-meg., 1/2-W.;
- One IRC resistor, 0.2-meg., 1/2-W.;
- One IRC resistor, 50,000 ohms, 1/2-W.;
- One IRC resistor, 50,000 ohms, 2 W.;
- One IRC resistor, 75,000 ohms, 2 W.;
- One IRC wire-wound resistor, 10 ohms;
- One Solar electrolytic condenser, 4-4 mf., 450 V.;
- One Solar electrolytic condenser, 4 mf., 450 V.;
- One Solar electrolytic condenser, 10 mf., 25 V.;
- Six Solar "domino" condensers, 0.25-mf., 200 V.;
- Three Solar "domino" condensers, 0.05-mf., 400 V.;
- Two Solar "domino" condensers, 0.1-mf., 400 V.;
- Three Solar "domino" condensers, 0.05-mf., 400 V.;
- Two Solar "domino" condensers, 0.005-mf., 400 V.;
- One Solar mica condenser, 0.002-mf.;
- One Solar mica condenser, 700 mmf.;
- One Solar mica condenser, 25 mmf.;
- \*One case, 5 x 6 x 9 ins.;
- \*Eight bar knobs;
- \*Two D.P.D.T. toggle switches;
- \*Two octal sockets;
- \*Two 4-prong sockets;
- \*One 5-prong socket;
- \*Two insulated grid caps;
- One RCA Radiotron type 913 tube;
- One RCA Radiotron type 885 tube;
- Two RCA Radiotron type 1V tubes;
- Two RCA Radiotron type 6J7 tubes;
- \*Two special sockets;
- Six binding posts;
- \*One 8-pt. switch;
- \*One 3-pt. switch;
- \*One 3-position toggle switch;
- One power cord;
- One pilot lamp and socket;
- Hardware, wire, etc.

\*Names of manufacturers will be sent upon receipt of a stamped and self-addressed envelope.

## XMTR MANUAL

The Kenyon Transformer Co. Inc. has just released a new booklet, edited by J. B. Carter, bearing the title "Amateur Transmitter Manual" which contains 64 pages of circuits, data, graphs and informative reading matter which will be of interest not only to "hams" but also to radio technicians in general. The 14 pages of graphs alone, provide a valuable source of reference in solving technical problems. This booklet is priced at 25c. (Booklet No. 1324.)

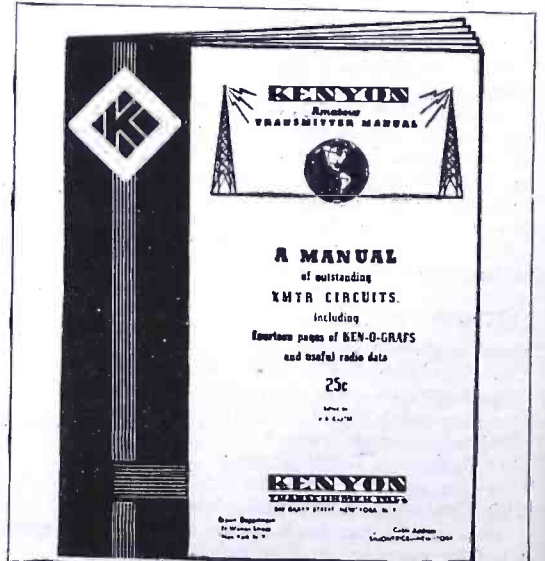

Please Say That You Saw It in RADIO-CRAFT

# HERE IS A GENERAL-PURPOSE HI-FI P.A. AMPLIFIER

(Continued from page 605)

existing systems, or as the complete amplifying system for an unusually powerful and fine electric phonograph.

It may further be used as a standard audio system in a laboratory developing radio receivers, or for the experimenter may serve not only as the audio system for his radio receiver, but it is also the complete "A," "B" and "C" power supply for the entire radio set as well.

Providing 55 db. voltage gain, so that it requires only 1 V. of A.F. to produce the full 32 W. power output at not over 2 per cent total harmonic distortion, it has a frequency characteristic flat to less than 1 db. from 30 to over 20,000 cycles—or over a far greater audio range than will ever be needed outside a laboratory! Deriving all of its own operating power from any 115-V. 50- to 60-cycles A.C. light socket, it not only provides 32 W. of excitation to the field of its own special speaker, but has a power socket from which can be drawn 4.5 A. at 6.3 V. A.C. and 110 ma. at 300 V. of well-filtered D.C. This extra power can be used to power a pre-amplifier, to power a multi-tube radio tuner, or to deliver 33 W. for the excitation of additional speaker fields. Yet this giant of flexibility and power is only 5½ x 7½ x 11 ins. long!

The secret of its unusually fine performance lies not only in its thorough and up-to-the-minute design, but in the super-efficient 18-in. loud-speaker which is a fundamental part of it. Not only does this speaker cover with exceptional fidelity the full audio tone range of 30 to 9,000 cycles, but its 35 per cent (7 times customary) efficiency results in an acoustic or sound power output equal to 224 W. fed into any ordinary 5 per cent efficient speakers, i.e.: 32 W. into a 35 per cent efficient transducer (loudspeaker) gives 11.2 acoustic watts, and 224 W. fed to a 5 per cent efficient transducer likewise gives 11.2 acoustic watts output. This is sufficient power to be comfortably heard by 50,000 people at once, or by several times this number if more than one speaker is used for wide-angle sound dispersion.

Fundamentally, the circuit consists of a 6N7 dual-triode voltage amplifier and phase-inverter driving a pair of 6L6 tubes in class AB1 in push-pull. Power is had through a choke-input filter, with an effective ¼-mf. of input capacity used only to kill the lamination hum customary to unbypassed filter input chokes. Since a choke input filter inherently possesses excellent and very flat voltage vs. current regulation, the simple exchange of an 83Y for the single 5Z3 rectifier allows the extra 33 W. of power for preamplifier, extra speaker field, or radio receiver powering to be had, without upsetting operating voltages. Since the voltage gain of 55 db. is more than is ordinarily needed in a P.A. power amplifier, a ½-meg. gain control is included, so that gain may be adjusted to exactly balance with preceding input equipment.

Coupling condensers and resistors are so chosen as to give a response flat to less than 1 db. from 30 to above 20,000 cycles, as are bypass condenser values. The order of plate filtration required by the 6L6 power stage being less than that needed by the 6N7 voltage amplifier, the needed additional filtration for the 6N7 is had by a resistance-capacity filter of 50,000 ohms and 8 mf., a compact and economical means of filtering and isolating the 2 stages.

Since no driving power is needed, and only 1 V. input for full output, and since input impedances are far from critical, almost any number of 3-A amplifiers can be driven by a single small preamplifier—but unless day dreaming is indulged in there will never be need for more than 2 or 3 such in even the largest installations.

For radio or phono operation no preamplification is needed, while for crystal or similar "well-down" microphones, a single 6J7 audio pentode with ¼-meg. plate resistor and 0.1-mf. coupling condenser will lift the total gain to over 95 db. which is plenty, and add only a cost of a dollar to two since it gets "A," "B" and "C" power from the 3-A amplifier, to give a complete, distortionless and ultra-powerful P.A. system. This whole equipment will probably cost the Service Man less than \$80 for its extraordinarily fine performance.

This article has been prepared from data supplied by courtesy of McMurdo Silver Corp.

# Ready Now! A Great New ALLIED Spring CATALOG

156 PAGES OF INTEREST FOR EVERY SERVICEMAN, DEALER and AMATEUR!

Send for the new Spring 1937 ALLIED Radio Catalog! 156 big pages packed with Everything in Radio—more than 10,000 parts; 50 new Knight Radios; complete lines of Amateur transmitting and Receiving gear; newest analyzers, tube testers, tube checkers, oscillographs, etc.; Public Address systems from 8 to 60 watts; dozens of Build-Your-Own kits; Rurlpower generators and Windchargers; books, tools, etc. For more satisfied customers, finer work, and bigger profits, you'll find everything you need in this great book!

### Fastest Service—Lowest Prices

You can buy with confidence from ALLIED—Radio's Leading Supply House! Our tremendous stocks, our central location, our economical merchandising methods and our efficient shipping department mean greater values, faster service and lowest prices for you! For standard or special equipment, for every-day or hard-to-get parts, you'll find that ALLIED is your "Silent Partner"—ready to serve you faster and better in every way!

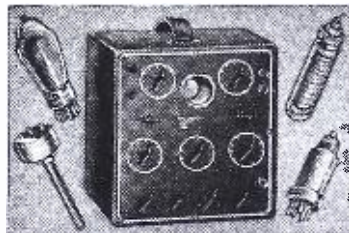

### MORE THAN 10,000 PARTS!

The new Spring 1937 ALLIED Catalog includes more than 10,000 exact duplicate and replacement parts for building or repairing any radio circuit. This means that you get what you want when you want it at ALLIED. Every part shown in the ALLIED Catalog is standard, highest quality, tested merchandise, built to deliver long, dependable, customer-pleasing service.

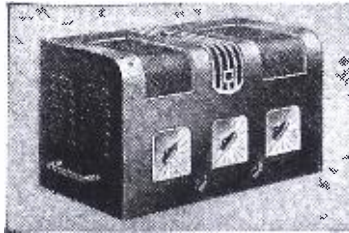

### NEW SOUND SYSTEMS!

See the newly designed Knight Sound Systems—8 to 60 watts—permanent, portable and mobile, for 110 volt, 6 volt and universal operation. Featuring the exclusive "Calibrated Output Indicator", higher fidelity, greater dependability, and beautiful new cases—at new low prices. Here are tremendous money-saving, profit-making opportunities!

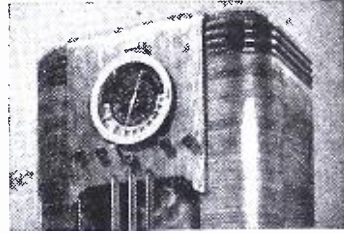

### 50 NEW KNIGHT MODELS!

The famous Knight line of Radios has been increased, improved and refined. The sensational 11 Tube Superhet with Automatic Dialing, AFC, Tone Expansion, etc.; new plastic radios; portable battery sets; phono-radio combinations, etc. 50 great models—5 to 19 tubes for AC, AC-DC, 6 volt, 32 volt, battery and auto operation—a set for every purse and purpose!



### NEW! MALLORY-YAXLEY SERVICE ENCYCLOPEDIA

Here it is!—all the information a Radio Serviceman needs for repairing any set ever made! Gives all the dope about replacement parts, circuit notes and service hints on more than 12,000 different radios. Easy to use, accurate—and priced amazingly low! **\$1.47**—for only .....

### WRITE TODAY!

ALLIED RADIO CORPORATION, 833 W. Jackson Blvd., Chicago, Ill. Dept. 2-D

Rush me your new Spring 1937 Radio Catalog.

Enclosed find \$1.47 (plus postage) for Mallory-Yaxley Encyclopedia.

Name .....

Address .....

City ..... State .....



**ALLIED RADIO CORPORATION**  
833 W. JACKSON BLVD. CHICAGO

## Be a RADIO EXPERT - Learn AT HOME

### RADIO SPECIALISTS NEEDED

Modern receivers with their complicated circuit systems have knocked out the old time cut-and-try radio fixer. Trained men with up-to-the-minute knowledge are needed to service these new sets.

### HERE IS YOUR OPPORTUNITY

Your possibilities of making money and getting ahead are limited only by your ability and skill—but you must know more than the other fellow. You must be a radio service specialist, as R.T.A. can train you.



**FREE OF EXTRA COST**

To start you making money without delay we equip you with this Circuit Analyzer and Point to Point Resistance Tester.

### PRACTICAL TRAINING AT HOME

Our home study course is practical "shop and bench" training combined with a thorough set of practical lessons prepared by an experienced Radio service engineer. Four working outfits are also furnished.

### MAKE SPARE TIME MONEY

Our training is complete and practical. We show you how to make money almost from the start. The course can easily be made to pay its own way. Investigate now, write for free book of details.

### WHAT R.T.A. STUDENTS SAY

Norwood, Ohio  
I have connected with a large firm as Radio Service Manager and wish to extend my thanks for your help.

Joseph Rapien, Jr.

Yorkville, Ohio  
From Aug. 1 to Dec. 7, 1936, I repaired 163 radios and put up 43 aerials which is very good for part time work while studying your course.

Chas. Koerber.

**RADIO TRAINING ASS'N OF AMERICA**  
Dept RG-74, 4525 RAVENSWOOD AVE., CHICAGO

Please Say That You Saw It in RADIO-CRAFT

# BIG FREE ELECTRICAL BOOK TELLS YOU HOW

**MANY TRAINED MEN EARN \$30-\$40-\$50 A WEEK AND MORE IN Electricity**

**YOU TOO can train for a BETTER JOB and MORE MONEY IN ELECTRICITY**

Do you want a BETTER JOB—MORE MONEY and a future free from Job Worry? Then send for my big free Electrical Book Today, and learn the FACTS about the amazing opportunities in Electricity—AND—how this new modern, up-to-date Practical Home Shop Training can help you qualify for these opportunities.

## PRACTICAL SHOP TRAINING ON REAL ELECTRICAL EQUIPMENT AND APPARATUS—RIGHT IN YOUR OWN HOME

"Learn-by-Doing" becomes a fact with this fascinating, new, modern, up-to-date Practical Home Shop Training in Electricity. With your instruction material, you get Electrical Equipment, Apparatus, Tools and Supplies with which you learn to do REAL PRACTICAL WORK—just like you would do out on the job. Don't you agree that this is without question the most PRACTICAL Home Training in America?

## OPPORTUNITIES TO EARN UP TO \$5.00, \$10.00 A WEEK AND MORE WITH SPARE TIME WORK WHILE TRAINING

We tell you how to DO these jobs, furnish real electrical equipment and supplies for many of them, and give you valuable Sales and Advertising helps to show you how to Sell Your Services. In fact, it should take only one or two small jobs a month to more than make the training PAY FOR ITSELF.

## TRAINING IN RADIO, REFRIGERATION, AIR-CONDITIONING, DIESEL ELECTRIC POWER and MANY OTHERS INCLUDED

My book also tells how E. I. Training helps YOU to INCREASE YOUR EARNING power still more by including training in these big, important branches of Electricity. Each one practically an industry in itself—each one a complete field—yet, you get all of these and more in E. I. Practical Home Shop Training.

## GET INTO A GROWING FIELD FOR A BIG PAY FUTURE

GET INTO ELECTRICITY—get into a field that is growing and expanding—get into a field where opportunities for REAL JOBS and REAL MONEY await the TRAINED MAN.

Naturally to qualify for these jobs you MUST BE TRAINED. In fact you want the BEST, the most Thorough and Complete, the most PRACTICAL Training, money can buy. We believe E. I. Practical Home Shop Training To Be That Kind Of Training. But, we don't want you to take our word for it. We want you to judge for yourself the value of this new modern up-to-date Training method—where you learn on Real Electrical Equipment and Apparatus—right in your own home. So send for my Big Electrical Book TODAY for full information on this new easy, interesting and Profitable Practical Home Shop Training. Remember this book cost you nothing—puts you under no obligation and NO SALESMAN WILL CALL ON YOU.

### Practical Shop Training on REAL Equipment

E. I. Training is DIFFERENT training. You get Real Electrical Equipment, Apparatus, Tools and Supplies to work on. This material comes to you as a regular part of your training at NO extra cost.



### "Learn By Doing" In Your Own Home

With this big outfit of equipment, you perform many interesting experiments, conduct important tests and do many real Electrical jobs, to make your training easy, interesting and PRACTICAL.



### Use Equipment for Many Money Making Jobs!

A great deal of this equipment can be USED in doing many profitable spare time jobs. Profitable because you will have no expense for the material you use. My big free book tells you more of this valuable feature of E. I. Training.



### Your Own Electrical Shop

This equipment comes to you throughout your entire training, starting the very DAY you enroll, so that as you progress with your training, you are building your own Home Electrical Shop with the Equipment, Apparatus, Tools and Supplies I give you.



### Get this Interesting Valuable Book TODAY!

Doesn't what I've told you sound interesting? Isn't it worth investigating? Ask yourself, could any method of Training be more easy, interesting or Profitable to the ambitious man or young man anxious to get into the BIG PAY field of ELECTRICITY.

**SEND FOR THIS BIG ELECTRICAL BOOK FREE**

H. W. Petersen, President  
Dept. 157D, ELECTRIC INSTITUTE, Inc.  
Hinsdale, Illinois

Send Free Book and full details of E. I. Home Shop Training.

Name.....Age.....  
Address.....  
City.....State.....

**INVESTIGATE - GET THE FACTS**

## MODERN SHORT-WAVE DIATHERMY

(Continued from page 598)

his own ingenuity in mounting the parts to suit individual cabinet requirements; in the instrument here described the components were distributed as shown in the photographs.

The bakelite panel supports the 0-300 ma. meter, variable condenser, electrode jacks, pilot light, and all the switches. The oscillator portion, directly behind the panel on the upper deck, is assembled on 1-in. seasoned plywood. The coils should be made and mounted so that they will not be influenced by vibration, with the output coupling coil mounted within the plate tank coil, as shown in the coil detail. The heavier equipment, consisting of the plate and filament transformers, type 866 rectifier tubes, and filter condenser, is mounted on the lower deck at the bottom of the cabinet.

All high-voltage leads are made with very heavy cable. An extra outlet, S2, placed in the side of the cabinet to permit the use of a foot switch when cutting is used. Provisions must be made for good ventilation as the tubes radiate considerable heat. To this end, grilles are placed at the top, bottom, and across the back of the cabinet, to provide for the proper circulation of air currents.

The high-voltage series condenser, C2, of about 0.002-mf., should be used so that the patient's circuit will be isolated from the tank circuit, should the tank and coupling coils by any chance touch each other.

Correction: In Fig. 1, Switch Sw.2 is shown incorrectly connected: It should be wired, in series, into the short lead that connects C8-R.F.C.4 to one side of the primary of P.T.1, and the former lead from this side of the primary to the pilot light permanently connected (just as it would be with Sw.2 in the old position and "on").

The next step is to tune-up the instrument for either (1) straight-forward diathermy or (2) special applications.

### ADJUSTMENT

(1) In tuning up the completed machine, with bias resistor R1 employed for straight diathermy, it will be found that the plate current will vary with the different positions of the electrode pads on the body. Plate current will be restored to the correct value when the output circuit including the pads is brought back to its resonant frequency by readjustment of the variable condenser, C1. Should less heat be desired, the plate current can be reduced by a further adjustment of C1. Under normal conditions the plate current for both tubes will read from about 150 to 250 ma.

(2) When the machine is to be used for special applications—(a) cutting, (b) cautery, (c) desiccation, or (d) coagulation—resistor R2 is connected into the circuit with a resultant drop in plate current.

This particular machine was designed to operate on 16 meters. Therefore, when the electrode pads (flexible metal plates imbedded in soft rubber) are chosen, the soft-rubber covered connecting cords should be of such length that the electrode units will resonate at this wavelength. I would suggest that the pads and cords be bought instead of attempting to make them at home. They are stocked as standard equipment at many surgical supply houses. The same applies to any other accessories used with the machine for other functions.

### DIATHERMY INTERFERENCE

A very great problem encountered in the use of diathermy equipment is that of radio com-

munications interference. A great stride towards the solution of this problem can be taken in the inherent design of the circuit. Note in the diagram the use of a 4 mf. filter condenser, C6, across the output of the power supply. This is essential to prevent oscillator instability under load, and the resultant setting up of spurious frequencies which cause pernicious interference.

The inside of the cabinet is lined with copper mesh wherever possible to act as shielding, and so reduce high-frequency radiation into surrounding house wiring and other metal materials used in home construction. (This mesh was removed before the photographs were taken in order to make the views more clear.) The input to the power supply, as can be noted, is filtered with an array of R.F. chokes and bypass condensers placed directly at the power transformer, P.T.2. These precautions take care of all that can be done at the machine proper.

Upon installation of the equipment, however, it may be found that these measures alone might prove inadequate. Therefore, another filter arrangement, similar to that in the input circuit, can be placed at the particular current outlet (wall plate, etc.) that feeds the machine. It should be borne in mind that success with any filtering method is entirely dependent on a very good ground being used in conjunction with it.

Although it is quite possible that they will not always be practicable, there are other measures that can be employed to eliminate interference. It is evident that although we have taken every precaution to prevent high-frequency currents from backing-up into the line itself, the problem of high-frequency radiation into space and surrounding conductive materials still remains. The shielding of the cabinet itself cannot be a complete cure, since the electrode pads which are necessarily external of the machine proper, are in themselves potent radiators.

One very efficient and modern method that may be employed is to have the walls of the room imbedded with chicken-wire which in turn is effectively grounded at several points. Another method is to construct a cage of this chicken-wire, with all supporting material of wood, and in turn ground the wire. The size of the cage, of course, must be such as to permit the accommodation of the machine, the doctor, and the patient. (See Note at end of article.—Editor)

The foregoing treatments for radio interference elimination will be found very effective in most cases. In some instances the cure will be up to the technician who makes the installation. He may find that one method will do the trick, or perhaps a combination of several.

Even though the reader may not be interested in the construction of a diathermy machine, this article will serve to inform him as to what constitutes an efficient, effective, modern machine.

(Note—One such cage is shown in Fig. 1. In size this cage measures about 6 ft. wide, 7 ft. deep and 6½ ft. high. Its construction details may be obtained [as a 4-page folder], from one

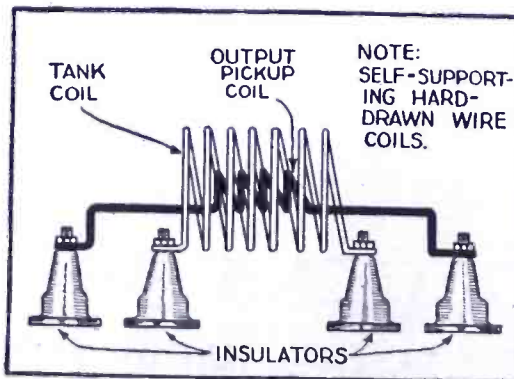

Fig. 4. Details of the R.F. coils.

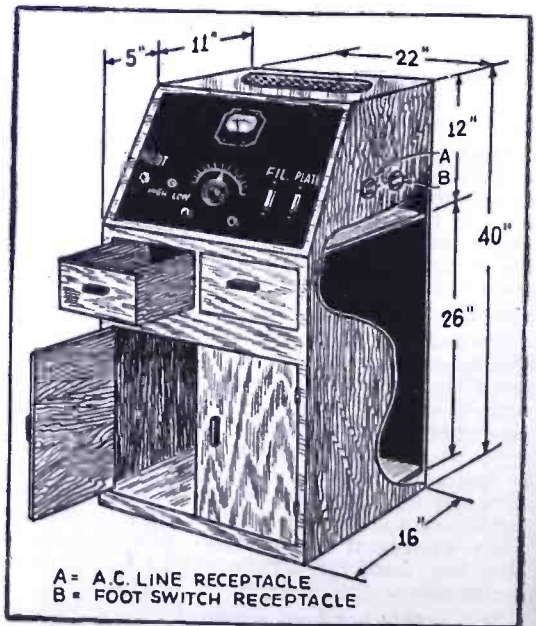
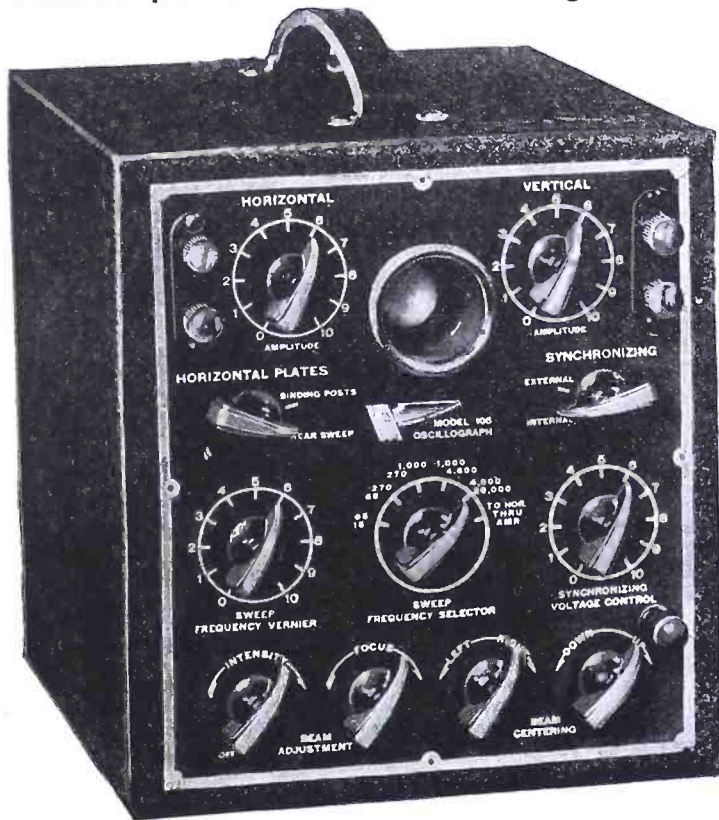

Fig. 5. Overall dimensions of the cabinet.

Please Say That You Saw It in RADIO-CRAFT

# HERE'S THE WAY YOU CAN OWN A NEW C-B OSCILLOGRAPH FREE!

Linear Sweep Circuit Synchronizing Circuit  
Dual Amplifiers Beam Centering Control



## SPECIAL LIMITED OFFER

Don't miss this chance to own a fine new oscillograph. Act quickly! Until March 31st you deposit only \$20.00 and agree to buy less than 8 National Union tubes per week for two years. You get the instrument immediately. After you purchase the required number of tubes YOUR DEPOSIT IS REFUNDED as a merchandise credit. After March 31st the deposit goes up to \$28.00, so SAVE \$8.00, ACT TODAY! Here's an instrument you need . . . let National Union give it to you.

**ACT QUICKLY—BEFORE MARCH 31!**

← This fine instrument would cost you \$48.90. Get it free the easy N.U. way.

National Union means more than radio tubes . . . National Union means MORE service business BETTER service business . . . AT A PROFIT!



National Union Radio Corp., RC 437  
570 Lexington Ave., New York, N. Y.  
Rush name of nearest N. U. jobber and send data on SPECIAL C-B OFFER.

Name .....

Street .....

City ..... State .....

**SEE YOUR JOBBER OR MAIL COUPON TODAY**

manufacturer specializing in interference-eliminating equipment, by writing on business stationery to *Radio-Craft*. To secure maximum effectiveness it may be desirable to install on the outside of the cage, where the power line is fed to the diathermy machine within, a special diathermy-type noise filter. This filter does not appear in the photograph of the cage but its approximate location on the framework at one corner is indicated in dotted lines.

Here is where the expert radio man comes into his own, for, he is well-equipped to properly install such equipment and check its efficiency by making suitable field-intensity measurements. Some idea of the importance of the relationship between medical practitioner and radio technician may be gleaned from the following quotation from a letter by a utility engineer who had just installed, for a doctor in Poughkeepsie, N. Y., a shielding cage similar to the one here illustrated.

"Noise meter readings were taken in the doctor's living room directly above the treatment room, showing 6 microvolts/meter at 1,400 kc. and 4 microvolts/meter at 1,000 kc. as compared with readings of over 2,000 microvolts/meter—terrific interference—before the screen was installed; this low mv./m. figure indicates almost complete elimination of direct radiation. A test made with the noise meter connected directly to the house wiring on an outlet in the living room gave only 12 microvolts/meter, which is an index of the filter performance."

(This really remarkable result is better realized when it is pointed out that man-made interference due to an improperly-installed diathermy machine has been known to cover thousands of square miles!—*Editor*)

### LIST OF PARTS

- \*One diathermy-type tuning condenser, 90 mmf. (max.), 3,000 V., type XP-90-KS, C1;
- Two Cornell-Dubilier fixed condensers, 0.002-mf., 5,000 V., C2, C5;
- Two Aerovox mica fixed condensers, 100 mmf., C3, C4;
- One Cornell-Dubilier fixed condenser, 4 mf., 3,000 V., C6;

- Two Aerovox mica fixed condensers, 0.006-mf., C7, C8;
- One Electrad (or, as \*illustrated) power-type resistor, 50 W., 2 sections—10,000 ohms, R1 and 50,000 ohms, R2;
- Two Hammarlund R.F. chokes, 2.5 mhy., 100 ma., R.F.C.1, R.F.C.2;
- Two Hammarlund short-wave (line) chokes, 5A., R.F.C.3, R.F.C.4;
- One Weston square-face meter, 300 ma., D.C., MA.;
- \*One filament transformer (fil. secs.: V1-V2, 6½ A. at 10 V.; V3-V4, 10 A. at 2.5 V.; 3,500 V. insulation), P.T.1;
- \*One power transformer (H.-V. sec.: 300 ma. at 1,550 V. each side of center-tap), type 6411, P.T.2;
- One coil (13 T. No. 10 enam. wire, wound 2½ ins. dia. and spaced 1 turn. Tap 4 T. each side of center), L1;
- One coil (5 T. No. 10 enam. wire, wound 1½ ins. in dia., spaced, between turns, about 1 in.), L2;
- \*Two diathermy tubes, type 100-TS, V1, V2;
- Two Sylvania, Raytheon, National Union or RCA Radiotron rectifier tubes, types 886, V3, V4;
- One Eveready pilot light, 110 V., 7 W., candelabra base, V5;
- \*Four ceramic, high-voltage sockets, for V1, V2, V3, V4;
- \*Two flush-mounting sockets (female sections for separable plug-in connectors), S1, S2;
- One Wholesale Radio Service Co. socket and

- bullseye for V5;
- \*One tuning-control knob for C1;
- Two fuses (one for each side of the power line; not shown in schematic, but recommended), and fuse holders;
- \*Three snap switches, Sw.1, Sw.2, Sw.3;
- \*Two insulated, base-mounting tip-jacks (for electrodes);
- \*One diathermy cabinet (it may be built in accordance with the directions given in Fig. 5; ventilate rear panel).
- \*The names and addresses of manufacturers will be supplied upon receipt of a stamped and self-addressed envelope.

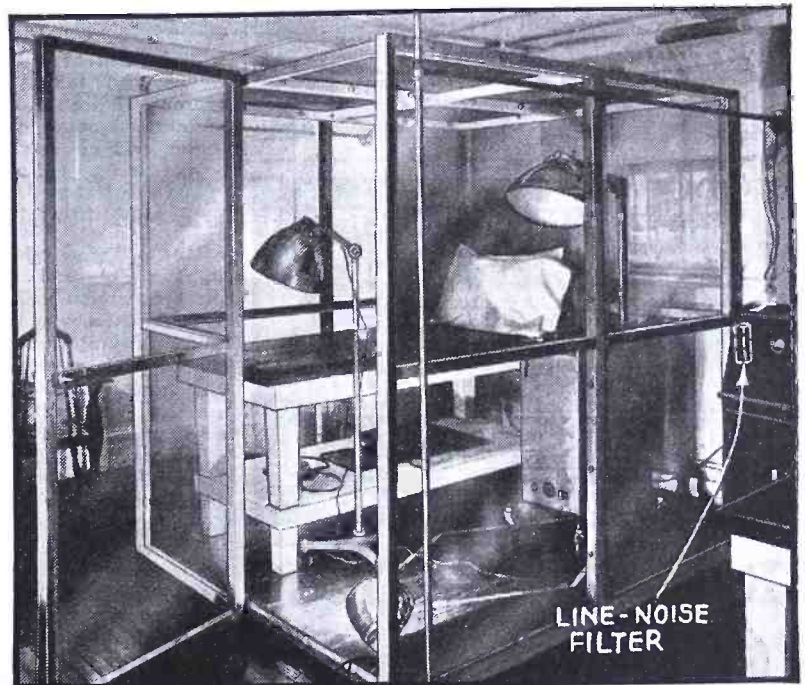

Photo—Tobe Deutschmann Corp.  
Fig. 1. The special shielded "diathermy booth" which prevents radiation of R.F. interference currents.

Please Say That You Saw It in RADIO-CRAFT

**NEWLY IMPROVED!** **Model T-37 SIGNAL GENERATOR**

- Accuracy 1/2 of 1% on I.F. Bands. 1% on Broadcast Band. 2% on S.W. Bands.
- We are now using a new hair-line pointer which enables reading to within 1/10 of 1%.
- Thousands of satisfied owners, since its introduction less than a year ago.



**Complete . . . only \$12<sup>40</sup>**

- 110 Volts A.C. or D.C.
- 100 kc.—22 megacycles all on fundamentals.
- Dial is direct reading in frequencies.
- R.F. output may be taken from a high impedance or a low impedance post, in with attenuation present for either.
- Separate audio output at 2 amplitude levels, so that tone may be used for checking public address systems, audio amplifiers in receivers, and speech amplifiers in transmitters.
- Two extra posts on front panel enable leakage tests. Condensers may be checked for leakage, so may tubes, and other normally high resistance currents, otherwise difficult to test.

Model T-37 All-Wave Signal Generator, wired, in shielded cabinet with carrying handle and calibrated, tested; complete with 2 Tubes & Neon Tube, \$12.40 instructions (shipping weight 7 lbs.) . . . . .

**SUPERIOR INSTRUMENTS COMPANY, 136 LIBERTY STREET NEW YORK, N. Y., Dept. 7A**

**OH, MA! THAT "SUGGESTION" CONTEST" IS IN AGAIN**

Last year's award in this contest went to Mr. Stanley E. Bialkowski, Wayne, Alberta, Canada. Will YOU win this year?

Unless you let us know what you want in "our" magazine how can we give you what you want? Remember, we are not mind-readers. So if you or your friends have any ideas as to what in your opinion would greatly improve RADIO-CRAFT, either in appearance, method of presentation, or subject matter, why, "lay on, MacDuff!"

**WIN A 2-YEAR SUBSCRIPTION TO RADIO-CRAFT**

Rules: There are no "strings" attached to this contest. Merely write your suggestions on only one side of a single sheet of paper and mail it, for receipt at our offices not later than March 31, 1937, to Radcraft Publications, Inc., 99 Hudson St., N. Y. C. Everyone, except employees of Radcraft Publications, Inc., is eligible. Here's a tip that may help you win: note that RADIO-CRAFT is designed to interest technicians in every branch of radio!

**FREE!**

**HAMMARLUND 25th YEAR RADIO CATALOG**

The most complete catalog ever published with special illustrations, drawings, curves and a complete description of the famous 16 tube "Super-Pro." Write Dept. RC-4-37.

**HAMMARLUND MFG. CO., INC.**  
424-438 West 33rd Street, New York

**FACTORY-TO-YOU SAVES 50%**

**New 14-TUBE 5-BAND WORLD-WIDE RADIO**

**\$39.95**

**EASY PAY PLAN**  
Write today for the new FREE 40-page catalog describing this bigger, better, more powerful radio. Over 40 advanced features. Glorious tone realism. Easy terms—10c a day. Money-back guarantee.

**14 TUBES FOR THE PRICE OF 8**

**MIDWEST RADIO CORPORATION**  
DEPT. M-12 CINCINNATI, OHIO

14 — 32 — 64 — 128 WATT UNDISTORTED

**6L6 BEAM AMPLIFIERS**

**DEAL DIRECT With Manufacturer AND SAVE BIG MONEY**

**ULTRA-QUALITY PERFORMANCE and FLAWLESS REPRODUCTION GUARANTEED FOR 5 YEARS!**

WRITE TODAY FOR OUR VALUABLE

**FREE CATALOG**

**INDUSTRIAL**  
AMPLIFIER SYSTEMS COMPANY

16-B HUDSON STREET, NEW YORK, N. Y.

**RADIO ENGINEERING**

RCA Institutes offer an intensive course of high standard embracing all phases of Radio. Practical training with modern equipment at New York and Chicago schools. Also specialized courses and Home Study Courses under "No obligation" plan. Catalog Dept. RT-37.

**RCA INSTITUTES, Inc.**  
75 Varick St., New York 1154 Merchandise Mart, Chicago  
Recognized Standard in Radio Instruction Since 1909.

**DIRECT-COUPLING IN A 30-W. BEAM-TUBE AMPLIFIER**

(Continued from page 601)

should be used (Fig. 2B).

The analysis of the stabilizing action of the entire system can best be illustrated by redrawing the rectifier diagram and one of the output tube circuits (V3) as indicated in Fig. 2C. For purposes of simplicity, the rectifier has been drawn as 2 D.C. generators connected in tandem. One of the 6L6 tubes is connected through 1/2 of the output transformer to the high-voltage terminal.

It will be noted that although 200 V. is applied to the cathode, the control-grid is 25 V. less negative (175 V. is applied to the control-grid), while the plate is 400 V. above cathode (600 V. above ground) and the screen-grid is at a 500-V. potential (300 V. above cathode). Under these conditions the no-signal current is 50 ma. for plate and 5 ma. for screen-grid. Approximately a 2,700-ohm bias will be required.

At full-signal conditions an increase of 19 ma. (combined increase of plate and screen-grid current) flows through R2 so that the cathode voltage would be raised 51.3 V. This degenerative effect not only lowers the available power output but also discriminates against the low frequencies so that these are practically lost. If the circuit of Fig. 2C is altered slightly as in Fig. 2E (a form of stabilized power supply) the cathode voltage remains constant at all values of plate and screen-grid current.

The reason for this is that an external bridge circuit is formed and all cathode current divided equally, half flowing through resistor R1, while the other half flows through R2. Voltage equalization takes place with the division of current, so that a constant cathode potential is maintained above ground. All of the plate and screen-grid circuits of the amplifier are of the bridge-circuit self-neutralizing type.

mary and secondary windings. In the face of these handicaps, circuits utilizing conventional phase inverters may be adjusted for true inversions at only one frequency and amplitude. As the frequency decreases, inversion is retarded and conversely as the frequency increases, phase inversion is accelerated. Thus, only within very narrow frequency limits will the inverted signal be 180 deg. out of phase with the original signal. Amplitude distortion is of course predominant in transformer inverters unless unusual care is exercised in the design and construction of the transformer.

The phase-inverter circuit shown in Fig. 2E typifies the simplest voltage divider and inverter available. It is entirely devoid of all capacitive and inductive reactance (excepting for the inter-electrode capacity of the tube element) and is capable of theoretically and practically equal division of a signal into 2 equal amplitudes and at the same time, inverting one of the signals 180 deg. out of phase with the other.

The plate load of the tube is divided into 2 equal, non-reactive parts and one section (pure resistance) is inserted in the cathode circuit forming the cathode-load resistor. During the positive cycle of the input signal, the plate current increases with a subsequent drop in plate voltage because of the increased voltage drop in the plate resistor (P1). The increase in cathode current raises the cathode voltage because of the increased current flowing through the cathode resistor (K1). Therefore, the potentials appearing across the plate and cathode of the tube are opposite in phase. As P1 and K1 are equal in value the amplitudes of the voltages developed across them are exactly alike.

**VOLTAGE DISTRIBUTION IN THE AMPLIFIER**

A casual study of the simplified amplifier schematic circuit Fig. 2F, will disclose a seeming haphazard distribution of voltages ranging from 600 V. on the plate of one 6L6 to 65 V. on the control-grid of the signal inverter. If a careful analysis is made however, it will be found that the relative voltages from cathode to control-grid, plate or screen-grid, are all in accordance with accepted tube ratings.

Of course, when the plate of one tube is coupled directly into the grid of the next tube, both the grid and plate have the same applied potential as measured from ground. It then becomes necessary to adjust the cathode and plate voltages of each tube so that, in relation to its grid, all voltages are as recommended.

In a 3-stage direct-coupled amplifier of this type, all voltages are additive. This accounts for the high voltage (600) applied to the plate of one of the 6L6 power output tubes.

Part III of this article, in July Radio-Craft, will contain a complete schematic circuit of the amplifier with some hints on its use.

This article has been prepared from data supplied by courtesy of Amplifier Company of America.

**THE NON-REACTIVE PHASE INVERTER**

Up to the development of the circuit shown in Fig. 2A and B, all existing methods of phase-inversion utilized a capacitatively-coupled system whereby a voltage opposite in phase but equal in amplitude to the signal voltage was picked off a preceding stage and fed back into the input circuit of some tube or tubes arranged to operate in push-pull fashion. The original intention of the phase-inverter was to eliminate the input push-pull transformer. Naturally, all the objections to resistance and transformer coupling mentioned before also hold for phase-inversion circuits.

The ideal phase inverter will equally divide the amplitude of a signal and separate their phases by 180 deg. Naturally, this action must take place equally well at all frequencies and amplitudes within limitations set by the tube itself. Any circuit utilizing a condenser cannot accomplish this because of the varying capacitive reactance presented by the condenser to the varying frequencies. Transformers are likewise limited in their phase-inversion action because of the varying inductive reactance of both of the pri-

Please Say That You Saw It in RADIO-CRAFT



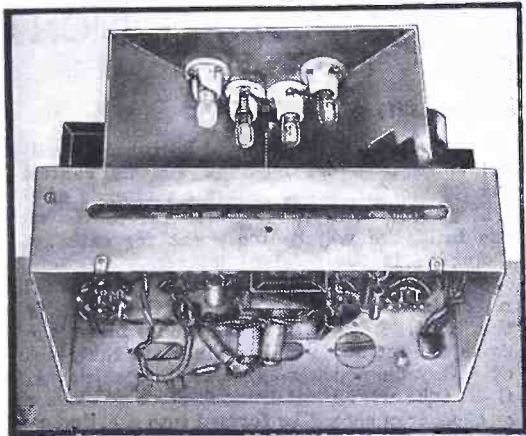

Fig. C. The positions of the argon lamps can be seen.

### MAKING THE RADIO KALEIDOCROME

(Continued from page 604)

constants specified in the List of Parts, is shown at right in Fig. A. It is a midget radio set, rebuilt slightly as a beat-type A.F. oscillator.) The bulbs are tiny, argon-filled G.E. glow lamps similar in appearance to the neon lamps used in many tube testers and continuity indicators. The lamps must be coated with a special fluorescent paint (available either transparent or translucent) which glows when the argon gas inside the lamp is ionized. These unusual fluorescent coatings produce a diffused light, of any desired color, which is very attractive. A sheet of ground glass further diffuses the light and produces a continually varying band of color which changes as the music is received. (The lamps may be obtained ready-colored as specified in the List of Parts.)

Each of the 4 lamps lights on a band of frequencies above and below the frequency mentioned above. The lamps are grouped in a V-shaped reflector made of polished aluminum to further mix the light as it is seen on the ground-glass panel.

The construction of the device is simple and any radio builder or experimenter can make one by following the schematic circuit, List of Parts and photographs.

The Kaleidochrome may be attached to any receiver without changing the wiring of the set or altering it in any way. Also, either the "color organ" or the "color tuner" may be built.

### THE "COLOR TUNER"

The tuning-light portion is entirely independent of the color organ and operates as follows:

As per Fig. 1, the 76 obtains bias from the A.V.C. voltage developed in the receiver to which it is connected. With no bias applied to its grid, the plate current rises to a value large enough to saturate the core of the special "tuning reactor." This, in turn, lowers the impedance of the secondary winding to a point sufficiently low to pass 300 ma. or more. This is sufficient to light the series-parallel pilot lamps (back of the slot in the chassis as shown in the photos) to full brilliancy. These 4 lamps are coated with ordinary red water-color paint, while the remaining 3 lamps are coated green by the same process.

The condition of brilliant light on the red lamps applies only when no signal is tuned in on the receiver. As the A.V.C. voltage increases with a signal the bias on the type 76 tube control-grid increases and the plate current

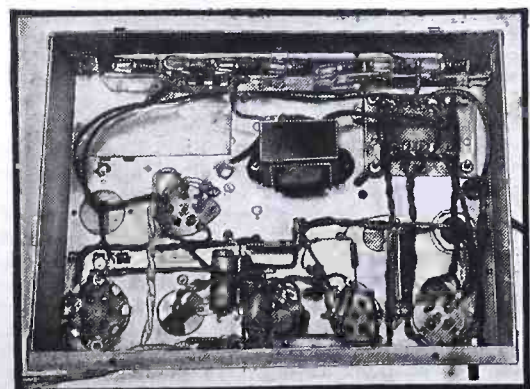
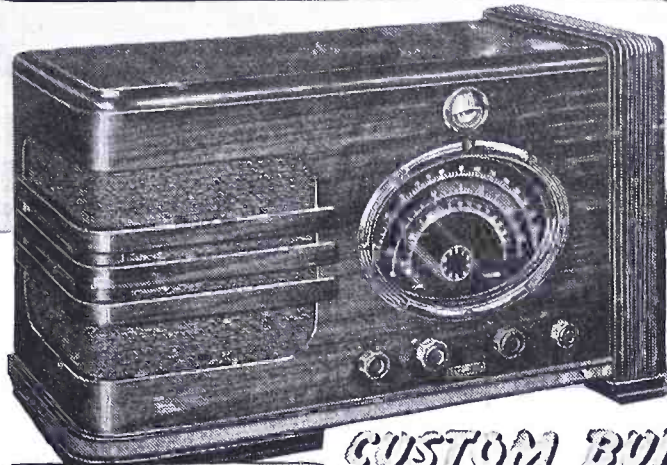

Fig. D. The under-chassis view.

"DROP IN TONIGHT AND LISTEN TO OUR NEW LAFAYETTE... IT'S A REAL THRILL."



## Lafayette 8 TUBE

### CUSTOM BUILT SUPERHET

This bargain in "THRILLS" can be yours, too! So ultra-sensitive is its superhet circuit, so outstanding its "in-the-studio" fidelity that we make this sensational challenge: put this world-famous Lafayette in your home... listen to it... THRILL to it... or get YOUR MONEY BACK! It takes a great receiver to make this challenge, and in every detail—"miracle-mirror" dial, automatic volume control, electro-dynamic speaker, cabinetry—this is a great receiver. ACT NOW! Accept our THIRTY DAY FREE TRIAL offer, you'll be glad you did.

**38 75**  
COMPLETE WITH TUBES, CABINET, ETC. NOTHING ELSE TO BUY



### SPRING CATALOG

Send for this new eye-filling, eye-opening catalog. Take advantage of the money-saving possibilities offered by the world's largest distributor of radio parts. See the new auto radios, the new Lafayette line of sound equipment, and the new Lafayette receivers. Marvel at a thousand and one other last minute values. Write for your copy—IT'S FREE.

**OTHER LAFAYETTE RADIOS AND PARTS**  
No matter what you require in radio, WHOLESALE has it. Five branches completely stocked with standard parts, tubes and every conceivable piece of radio equipment. Remember, WHOLESALE "super-swift" service will get you what you want when you want it!

Send for FREE parts list of circuits described in this magazine. Specify circuit desired.

### USE THIS COUPON FOR YOUR ORDER BLANK!... MAIL NOW!

WHOLESALE RADIO SERVICE, CO., INC.  
100 SIXTH AVENUE, NEW YORK, N. Y.

Rush new FREE 116 page catalog No. 68-3D7. Enclosed find check..... money order. ....for model BB-81.

Name.....

Address.....

City.....

State.....

Send orders to New York, Chicago, or Atlanta.

### WHOLESALE RADIO SERVICE CO.

NEW YORK, N. Y.  
100 SIXTH AVENUE

CHICAGO, ILL. ATLANTA, GA.  
901 W. JACKSON BLVD. 430 W. PEACHTREE ST., N. W.

### TERMINAL

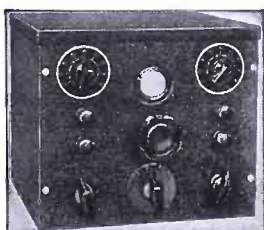

### "JUNIOR" Oscilloscope

(Featured in March Radio-Craft.)

#### A Real Buy!

The TERMINAL Junior Cathode Ray Oscilloscope is portable and complete for the serviceman and amateur. Suitable for:

- Analysis of wave forms.
- Visually determining the amount of distortion in A.F. amplifiers.
- Seeing percentage of modulation in x-mitter.

Complete kit contains cabinet, chassis, panel, all parts, including special power transformer \$11.95

Tube kit contains 1-913, 1-885, 1-6D6 and 1-80 \$8.45

Write to Bill Filler for complete information!

### TERMINAL RADIO CORPORATION

80 CORTLANDT ST., NEW YORK, N. Y.

Please Say That You Saw It in RADIO-CRAFT

Doing a world-wide job....

## little giant



### COMPACT Dry Electrolytic CAPACITORS

So small... efficient... completely equalling standard sizes in dependability! All usual capacities; two ratings, 450 v.w. and 200 v.w. You won't believe your eyes!

SOLAR MFG. CORP.  
599-601 Broadway, New York, N. Y.



Descriptive literature upon request.

**LEGAL ADVICE**  
Anywhere in Town  
**50¢**

Sounds ridiculous—and it IS! No lawyer would work for such a fee, nor would anyone expect to pay it. Years of training enable a good lawyer to collect good fees. The professional serviceman who likewise increases his ability by adequate professional training can also satisfy his customers with prices that will provide him with a good income.

**ADVANCED TRAINING IN  
RADIO SERVICE  
AND PUBLIC ADDRESS**

**TERMS AS LOW AS \$5 MONTHLY**

Smart men are insuring their futures by training now. Get complete details today about our complete home-study training that every serviceman can afford.



**Free Booklet**

"THE KEY TO SUCCESSFUL SERVICING"—illustrated and interesting. Write for your FREE COPY!

**RADIO SERVICE INSTITUTE**

Dept. RC-4-3308  
14th Street, N. W.  
Washington, D. C.

**BARGAIN BULLETIN**  
SAVE MONEY  
ON EVERYTHING  
YOU BUY!

**SPORTING GOODS  
WATCHES-CLOCKS  
TYPEWRITERS  
OPTICAL GOODS  
CAMERAS-NOVELTIES**

**RADIO SETS  
AND  
REPLACEMENT PARTS**

**SEND AT ONCE  
FOR OUR FREE CATALOG!**

Buy efficiently, economically, safely! Hundreds of high quality items—leading lines and standard brands—at prices amazingly low! Real bargains! Square dealing! Write today for your big, free copy of this new catalog hot off the press.

**RADIO CIRCULAR CO., INC.**

915 BROADWAY Dept. RC NEW YORK, N. Y.

**CLASSIFIED ADVERTISEMENTS**

Advertisements in this section are inserted at the cost of twelve cents per word for each insertion—name, initials and address each count as one word. Cash should accompany all classified advertisements unless placed by a recognized advertising agency. No less than ten words are accepted. Advertising for the May, 1937, issue should be received not later than March 6th, 1937.

**DOGS**

**TERRIERS: ALSO BULL PUPS. SHIP ANYWHERE.**  
Bob Tonn, Dallas, Texas.

**WIND ELECTRIC PLANTS**

**BUILD WIND LIGHT PLANT FROM AUTOMOBILE generator.** Dime brings complete plans and catalog. Fan Belt A. C. Generator; 50 other changes. LeJay Manufacturing, 1451 Lake, Minneapolis, Minn.

**HOW TO MAKE THE RADIO-CRAFT—1937 TELEVISION RECEIVER**

(Continued from page 597)

aerial rods are supported horizontally instead of vertically.

In the aerials in Fig. 7C, E, and F, "twisted pair" can be used to replace the spaced down-leads, if desired, and with very little difference in operating efficiency. The length of the lead-in is not very important.

Incidentally, coils are now manufactured for the aerial and oscillator circuits of the tuner chassis of this set. These coils have the correct inductance to cover the television bands. The telescoping, rod-type aerial, and several of the smaller parts, such as rubber grommets, grid clips, etc., are also available from the same source. Those who wish to obtain these parts ready-made instead of making them at home can obtain them by writing to *Radio-Craft* for the name of the manufacturer.\*

**SWEEP ADJUSTMENT**

In Part III, the value of the vertical sweep-frequency condenser C40 was given as 0.004-mf. and the horizontal sweep-frequency condenser C43 as 0.5-mf. These values are correct for 441-line interlaced scanning as used in the experimental transmissions of RCA in New York and Philco and Farnsworth in Philadelphia. However, for television experimenters on the Pacific coast, who wish to pick up the transmissions of the Don Lee system, the value of C43 may have to be changed to a 0.5-mf. condenser in parallel with a 0.05-mf. unit (both 400 V. D.C.) in order to reach the frequency of 24 cycles required for the low-frequency sweep. The high-frequency sweep for this system is 7,200 cycles which can be reached with the specified condenser.

**THE LENS SYSTEM**

In the photographs accompanying this concluding Part of the series, it will be noticed that a lens system increases the size of the images from 2½ ins. (on the end of the 3-in. C-R tube) to about 8 ins. This lens system which contains 2 lenses having a very short focal length was taken from an old scanning-disc-type television receiver made by the now defunct Jenkins Television Corp. Quite a number of these lenses are available from "second-hand" radio dealers but if the experimenter cannot obtain one, a suitable lens may be obtained from any reliable optical glass manufacturer (such as those who supply lenses to amateur telescope makers) to enlarge the images as much as possible without introducing serious distortion in the form of spherical aberration, etc.

As a last resort, quite presentable images can be seen directly on the end of the tube and in order to intensify the apparent brilliance of these images a wooden funnel, of the size shown in Fig. 8, should be made and painted with flat-black (or "lamp black") paint on the inside. The images when viewed through this funnel appear very clear—though rather small.

The cabinet in which the set is housed should be made from ¾-in. plywood, finished in any desired manner. The 9 controls on the side of the sweep and C-R. tube chassis should pass through holes in the right-hand side of the cabinet, so that they can be adjusted when necessary. The actual tuning control and the volume controls for video and audio channels are located on the front panel, below the image lens.

**ADJUSTMENTS**

Although explicit instructions are not given for adjusting the receiver for the reception of images, the experimenter will need a few hints in order to get started. After this, it is a matter of cut and try in order to get the various parts of the set adjusted for best results at the particular location at which the receiver is used.

When the various adjustments have been made to line-up the I.F. circuits and the "sounds" of the television signals are received (on headphones connected to the output of the video channel on the receiver chassis) with the greatest intensity, the next problem is to adjust the C-R. equipment to synchronize with the transmitter.

When the two chassis are tied together by connections A, B and C, the various potentiometers on the C-R. chassis should be turned to the mid-position as a starting point. Without any carrier tuned in, the sweep amplitude controls should be varied until a clean-cut rectangle of light is seen on the end of the C-R. tube. The

intensity control R35, should be turned until the brilliance is about medium. If this control is turned too far to the left, the rectangle of light will go out, while if it is too far to the right, the brilliance will be too great for satisfactory definition in the received images.

With no signal being received, there should be no darkening or variations in the intensity of the light. Any variations which move up or down the rectangle of light indicate the presence of A.C. hum which may necessitate shielding the C-R. tube with sheet iron. A piece of stove pipe or sheet iron should be formed into a cylinder and fitted over the "sleeve" portion of the C-R. tube and carefully grounded to the chassis. It will also be found that reversing the connections to the heater of the C-R. tube will sometimes reduce the "hum" since the cathode connects to one side of the filament and correctly polarizing this filament is important.

Next, the television station should be tuned-in, and this should automatically tune-in the sound accompaniment (if one is being transmitted). The remainder of the procedure consists of "twiddling" the vertical and horizontal frequency controls, the gain controls of the sweep circuits and the gain of the amplifier in the C-R. chassis until satisfactory images are seen.

If a large number of black and white dots are seen on the tube, the high-frequency scanning circuit is too high or too low in frequency. If the images move up or down, the low-frequency sweep is off. If more than one image—or parts of several—are seen, the low-frequency oscillator is at too high a frequency and should be adjusted.

In some locations, where the signals are too weak to swing the image from brilliant to dark, it may be necessary to add one or more additional stages of I.F. amplification to the video channel.

In closing, let us once more point out that a cathode-ray television receiver operates with high voltages and a severe shock can be encountered at many parts of the receiver and C-R chassis of the set. It must be understood that *Radio-Craft* incurs no liability in connection with any accidents due directly or indirectly to the information published. This does not mean that an experienced person has anything to fear from the set—if it is carefully built. (Any more than a person should look askance at a high-power amateur phone or code transmitter, thousands of which are in daily operation.) But—ALWAYS turn off the current before touching any exposed or metallic parts of the set or power supply.

*Radio-Craft* wishes to thank the several individuals and companies who cooperated in making the design and construction of this experimental television receiver possible.

As changes and improvements are made—to keep abreast of future developments and additional work in the laboratory—these changes will be described.

\*Names of manufacturers will be supplied upon receipt of a stamped and self-addressed envelope.

**MAKING THE RADIO KALEIDOCROME**

(Continued from page 623)

is reduced. The saturation of the core of the "tuning reactor" diminishes and the impedance of the secondary becomes so great that very little current can flow through it. In this case, the green lamps will light up brightly but because they are series-connected, a current of only 150 ma. is required for full-brilliance. The same current will pass through the red lamps, but they will light very dimly because of the lower resistance of the series-parallel circuit.

The schematic diagram, Fig. 1, shows the wiring and the actions explained above can be understood more readily by examining it.

In making the Kaleidochrome, the layout of parts as indicated in the photographs does not necessarily have to be followed exactly. The builder can use his own ingenuity in the way in which the actions of tuning and color variation are presented. It will be found best, though, to use the angular mounting of the lamps to diffuse the light as much as possible and prevent the formation of "spots of light" on the ground glass screen.

Please Say That You Saw It in RADIO-CRAFT

## THE LATEST RADIO EQUIPMENT

(Continued from page 599)

the 30 outstanding features of this newest in signal generators for the progressive Service Man. Following are a few of its more outstanding attributes. Will measure receiver sensitivity, stage gain, translation gain and selectivity; frequency range: 100 kc. to 75 mc. (30 per cent, 400-cycle modulated); cantilever chassis construction. Weight, 15 lbs.; the amazingly small size is evident by comparison with the snap switches.

### SHIP AHOY! A MARINE P.A. UNIT (1320)

(Wholesale Radio Service Co., Inc.)

HERE is a 20-W. deluxe portable unit especially designed for boats. Use for paging, crew calls, musical entertainment, etc.; speaker horn is suitable for hailing passing vessels or in giving docking instructions from the bridge (a la past issues of *Radio-Craft*).

### POCKET-SIZE MULTITESTER (1321)

(Radio City Products Co.)

A BAKELITE case, d'Arsonval meter with knife-edge pointer, and 2 per cent accuracy are constructional features of this instrument. The outstanding merit, though, is its scope in such compact form; ranges: 0-550 microA.; 0-5-50-500 millia.; 0-5 A.; 0-5-50-500-1,000 V.; 0-500-50,000 ohms and 1. meg. Virtually 12 meters in one!

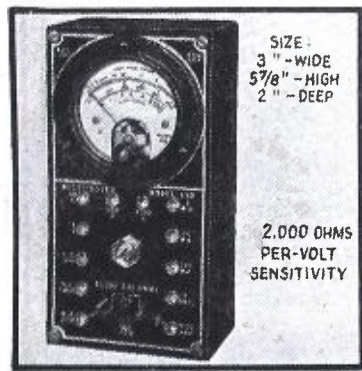

SIZE -  
3" - WIDE  
5 7/8" - HIGH  
2" - DEEP  
  
2,000 OHMS  
PER-VOLT  
SENSITIVITY

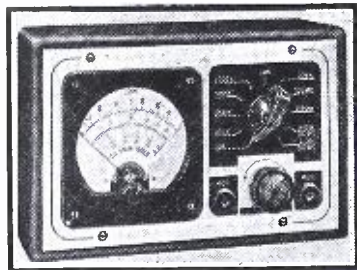

Above, new 11-range meter measures 7 x 4 1/2 x 2 1/2 ins. deep. (1323) Shown at left is a veritable "12-in-1" portable meter. (1321)

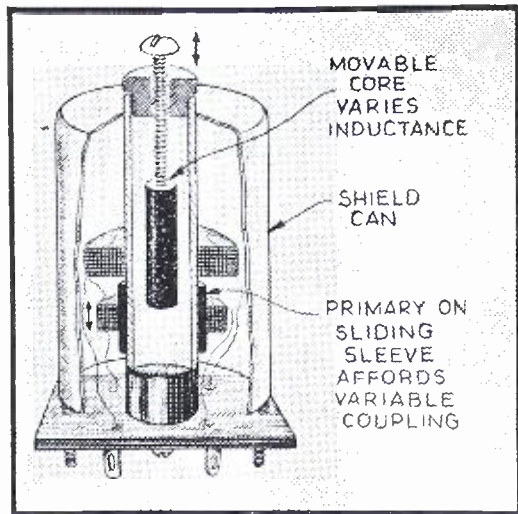

Inductance mismatch is corrected. (1322)

### UNIVERSAL-TYPE R.F. COIL (1322)

(Carron Mfg. Co.)

A NEW line of compact coils, ideal to fit varying demands as R.F., antenna, oscillator, and preselector service, is now available. Adjustable core, high-perm. iron, varies inductance over 25 per cent, to compensate for variations in I.F. tuning and wiring capacities, tube characteristics, etc.; shield can is 1 3/8 ins. in dia.

### 11-RANGE METER (1323)

(Precision Apparatus Corp.)

A SQUARE meter of 3-in. size is utilized in this bakelite-encased instrument. Voltage ranges: 0 to 1,000 in 5 steps at 1,000 ohms volt; current: 0 to 250 ma. in 4 steps; resistance: 0 to 500 ohms and 0 to 0.3-meg. Unit is selector-controlled; d'Arsonval meter permits 2 per cent accuracy. Leather-finish case.

## ORSMA MEMBERS' FORUM

(Continued from page 610)

I hope that I will get many particulars from you.

A. F. L. de QUANT,  
De Quant's Radio Service,  
Larixlaan 32,  
Den Haag, Holland.

We have printed Mr. de Quant's letter in its original arrangement. Certainly, our "Hollandaise" could not approach in perfection his "English"—and as to technical ability, well, having regularly received several Holland radio magazines over a period of years we have acquired a wholesome respect for their grasp of the art's finer points.

### NEW YORK: HELP AN ORSMA MEMBER

RADIO-CRAFT, ORSMA Dept.:

I am a Service Man of ORSMA but have been in this hospital for 2 years and am attempting to do whatever service work I can but am lacking testing equipment.

I can't afford the modern equipment at present but thought perhaps you would know where I could purchase an old model that perhaps I could alter to suit my needs until such time as I could purchase a modern analyzer; even an ohmmeter would stand me in stead.

Hoping you can be of help to me, I remain

CHAS. F. HOSCHKE,  
c/o Sea View Hospital,  
A-3, Staten Island, N. Y.

How about it, Members? Maybe you have a

piece of test apparatus, that you don't need, which you could pass on to a game fellow who is trying hard to face life with a smile?

### WEST VIRGINIA: A TIP FOR SERVICE SHOPS

RADIO-CRAFT, ORSMA Dept.:

We are sending a photo of our service bench which we would like to see in the ORSMA Forum. We are members of the ORSMA.

Our bench is much too long to show in its entirety, but the photo gives some idea of its appearance. The equipment includes the following: Supreme model 85 counter tube tester, model 19 tube tester, model 385 automatic analyzer, model 90 analyzer; signal generator; high-voltage neon condenser tester; substitute condenser tester, and several other small units which are home-made. Suspended desk lamps slide on a tight-wire. (See view on page 610.)

The shop testing equipment is mounted in a sloping panel of wood which places the instruments at the most convenient angle for observation. The units are held in place by gravity and thus are easy to remove.

W. B. DAVIS,  
Davis Radio Service,  
Weston, W. Va.

### PUBLIC ADDRESS NUMBER

MAY RADIO-CRAFT will describe a woofer-and-tweeter hi-fi infinite-baffle speaker system, a 1-tube set using only a "magic eye" tube, a deluxe inter-office phone and radio set, and many other items.

Please Say That You Saw It in RADIO-CRAFT

# New "PRECISION" MULTIMETER SERIES 830

An eleven range service instrument with a large 3 inch square meter of modern design . . .



SMALL IN SIZE (4 1/2 x 7 x 2 1/2)  
A GIANT IN UTILITY

Quantity production makes possible this very low price of

# \$10<sup>95</sup>

(Net wholesale price)

## LOOK AT THESE FEATURES

- ★ 5 D.C. voltage ranges: 0-10; 0-100; 0-250; 0-500; 0-1000 at 1000 ohms per volt.
- ★ 4 D.C. current ranges: 0-1 ma; 0-10 ma; 0-100 ma; 0-250 ma.
- ★ 2 resistance ranges: Low ohms shunt method. 0-500 ohms. As low as 1/2 of an ohm. High ohms reading. 0-300,000 ohms.
- ★ Large 3" square meter of modern design and highest quality; housed in bakelite case; D'Arsonval type; 2% accuracy. Employs top and bottom bridges; highly grained jewels; rounded pivots; specially designed pole pieces for equalized flux distribution; reinforced needle pointer. Will withstand rough usage.
- ★ Large easy reading scales.
- ★ Selector controlled throughout; only two polarized pin jacks on panel.
- ★ Wire wound shunts of 1% accuracy used.
- ★ Metal etched panel attractively finished.
- ★ Compact size; 4 1/2 x 7 x 2 1/2.
- ★ Leatherette covered case.
- ★ Self-contained battery included.
- ★ Accurate and adequate voltage, current and resistance ranges for point to point set testing.
- ★ Zero adjust compensator for accurate resistance readings.

See your jobber . . . If not in his stock, order direct for rush shipment . . . Include name and address of your parts jobber.

# PRECISION APPARATUS CORP.

821 EAST NEW YORK AVENUE  
BROOKLYN, NEW YORK

# News for you- MR. RADIO MAN



*If-* you were to receive over 150 pages of important, *new* GERNSBACK service data and diagrams every month of the year

*And-* at the end of a twelve month period you had received well over 1,800 pages of this GERNSBACK service material

*With-* over 3,000 diagrams and illustrations which covered twelve hundred different manufactured receivers; and

*Suppose-* you were told that it would not be necessary to pay in advance for this,

*But-* payments could be arranged in convenient terms to meet your purse,

*Perhaps-* you'd sit down and scratch your weary head trying to figure it all out. Instead

*Why-* not fill in the coupon below and send for the circular which explains this interesting news. Insert coupon in an envelope or paste on a one cent postcard and mail it to

**RADCRAFT PUBLICATIONS, INC.**  
99 HUDSON STREET NEW YORK, N. Y.



RADCRAFT PUBLICATIONS, Inc. RC-437  
99 Hudson Street, New York, N. Y.

Gentlemen: I am interested in learning more details of your plans which are only briefly outlined in this advertisement. Please send me promptly, a FREE copy of your colored brochure entitled, Announcing A New Gernsback Service for Radio Men.

Name .....

Address .....

City ..... State .....

Please Say That You Saw It in RADIO-CRAFT



# G.E. PHONOGRAPH MOTOR

Formerly Sold for \$15.00

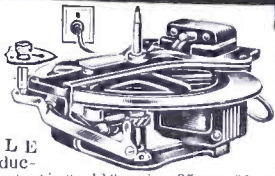

Only \$4.95

**VARIABLE** speed induction type self-starting, 110 volt, 25 to 60 cycle, A.C. with speed control. Plug and cord. Speed range from 5 to 200 RPM. Can be installed in place of old-fashioned, hand-winding speed motor. Also ideal for display turn table, and a hundred other uses. These General Electric Motors are brand new, in original factory cartons. **\$4.95** G.E. Electric Phonograph motor as described. Shipping Weight—12 lbs.

# WESTINGHOUSE UNIVERSAL MOTOR

**\$2.95** 110 Volts AC and DC

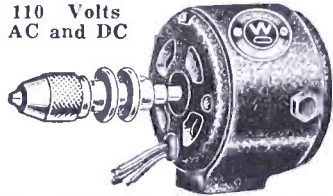

Shipping Weight 3 lbs.

THESE Motors are manufactured by the Westinghouse Electric Co. They are absolutely new. Specifications: 1/30 H.P. operates on either A.C. or D.C., 110 volts, 5000 R.P.M. Rheostat can be used to vary speed. Height 3 3/4", Length 3 3/4", Width 1 1/4", Shaft 1/4" one inch long. Can be used to drive Sewing Machines, Models, Buffing Lathe, Polishing Head, Drills, Grindstones, etc., etc.

MOTOR only ..... **\$2.95**  
 MOTOR with Arbor and 1/4" Chuck ..... **\$3.95**  
 Add 25c for special packing and mailing anywhere in U. S. A.

# MICROPHONE and RECEIVER

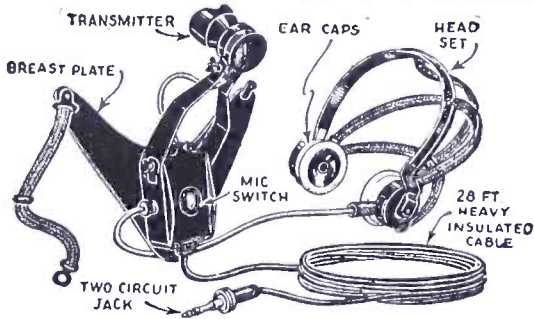

THIS Microphone and telephone headset outfit was built especially for the U. S. Navy Aviation Corps. The Holtzer-Cabot Electric Company constructed the outfit to Government specifications. The outfit consists of a low-impedance carbon microphone (transmitter), securely fastened to a metal breast-plate, and a set of heavy-duty, low-impedance earphones. A specially constructed switch on the back of the breast-plate controls the microphone circuit. The earphones are U.S.N. Utah type, attached to adjustable headband. Twenty-eight feet of very heavy weather and waterproof conductor cable is furnished. Current of not more than 10 volts should be used. A storage battery is the most satisfactory current supply. **\$4.96** U. S. Navy Airplane-type Microphone and Receiver as described. The shipping weight is 9 lbs.

# WESTINGHOUSE POWER GENERATOR

Manufactured for U. S. Signal Corps  
 A.C. Electrical 200 Watt 110 V. AC Power

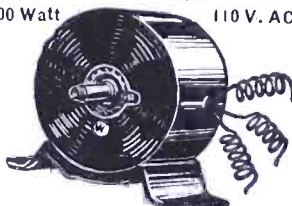

from a Windmill, from available Waterpower, from your Automobile, from your Motorcycle, from your Bicycle, Foot-pedals or Handcrank (for transportable Radio Transmitters, Strong Floodlights, Advertising Signs); do you want to operate AC Radio sets from 32 V. DC farm light systems; operate two generators in series to get 200 V. AC; obtain two phase and three phase AC, etc., etc. 1/4 to 1/2 H.P. needed to run generator. There are over 25 Applications, such as: A.C. Dynamo light from eight to ten 20 Watt 110 Volt lamps. Short Wave Transmitter supplying 110 Volts A.C. for operating "Ham" transmitter. Operating 110 V. AC 60 Cycle Radio Receiver in DC districts. Motor Generator. Public Address Systems. Electric Sirens on motor boats, yachts, etc. Camp Lighting, etc., etc. Blue-Print 22 x 28 in. and Four-Page 8 1/2 x 12 in. Instruction Sheets. Generator, as described including four replacement carbon brushes. **\$7.90** Shipping weight 18 lbs.

All merchandise in original packages—never used. Money-back guarantee.

We will forward Shipments by Express Collect if sufficient postage is not included.

# WELLWORTH TRADING CO.

560 W. Washington Blvd., Dept. RC-437, Chicago, Ill.

# HOW TO MAKE THE RADIO-CRAFT STANDARD TUBE TESTER

(Continued from page 589)

## OPERATING THE TESTER

It is very important that the following instructions be memorized and that the same procedure be carried out every time a tube is tested.

First, turn all 4 selector switches to the blank indicator positions at the bottom of the scales. Connect the line cord to the A.C. circuit and the tester is ready to work.

**Short and Leakage Tests.** When making short and leakage tests be sure that the tube selector switches are at the Off position. Turn the short test switch through the various test positions at 2-3, 3-4, C-2, etc. The neon will glow brightly when a short occurs at any position of the switch. High-resistance leaks will be indicated by a dim glow of the neon.

Always make the short test first. If the short test is made after the tube has been heated there may be a glow from the neon for a short period of time even though there is no leakage in the tube. This false glow will rapidly disappear if the tube is not leaky.

Hot-cathode leakage tests can be made as follows. Set the tube selector switches to the proper positions as indicated in the Reference Chart. Set the Short Test switch to KL. There should be no indication on the test meter if there is no leakage. Any reading indicates leakage between heater and cathode.

**Tube Testing.** After the short tests have been made and the tube tests OK proceed to test the tube in the following manner. Note: allow ample time for the tube to heat and set Line Voltage Control so that the pointer on the A.C. meter is at the arrow.

- (1) Turn the Short-Test Switch (Sw.3) to the "T" position.
- (2) Adjust the Filament Selector Switch (Sw.4) as indicated on the chart.
- (3) Reset the Line-Voltage Control so that the pointer is properly set at the arrow.
- (4) Adjust the Shunt Control, R5, to the numerical setting indicated on the chart.

(5) Permit the tube to heat and note reading GOOD, or POOR.

Combination types of tubes with 2 sets of elements are tested individually as indicated in the Reference Chart. The 2 sets of elements are listed as A and B.

Rectifier Tubes are listed as (HW) half-wave, (FW) full-wave. Diode sections are listed as (D). A reading beyond the line marked "DIODES OK" indicates a good diode section.

In some cases one setting of the tube selector switches is indicated. When this occurs the second selector switch can be in any position without affecting the test. However, it is best to set the unused selector switch at the "blank" position for such tests. This will help to avoid confusion.

When making Shunt settings be careful not to force the knob as this will upset the calibration of the instrument.

**Resistor Measurement.** A type 84 tube is used for resistance and capacity measurements. This tube should be tested before it is used and the meter reading should be 40 when the shunt is set at 90. The Filament Selector Switch setting for this tube is 7. Do not use a tube that will not give a reading of 40. Do not touch the live ends of the test prods as the voltage across them is more than 100 V.

Set the Short Test Switch to the "R" position and adjust the line voltage meter pointer to the arrow on the dial scale.

Connect the test leads to the tip-jacks and short the opposite ends. Adjust the shunt until the meter reads full-scale (50). If the meter will not adjust to full-scale by varying the Shunt, reset the Line Voltage Control until it does.

Connect the test leads to the resistor or circuit to be measured and note the meter reading. Refer to Fig. 3 and note the value of resistance. A reading of 34 on curve "A" indicates a resistance value of 13,000 ohms.

Resistors having a value greater than 50,000 ohms can be checked by setting the Shunt to

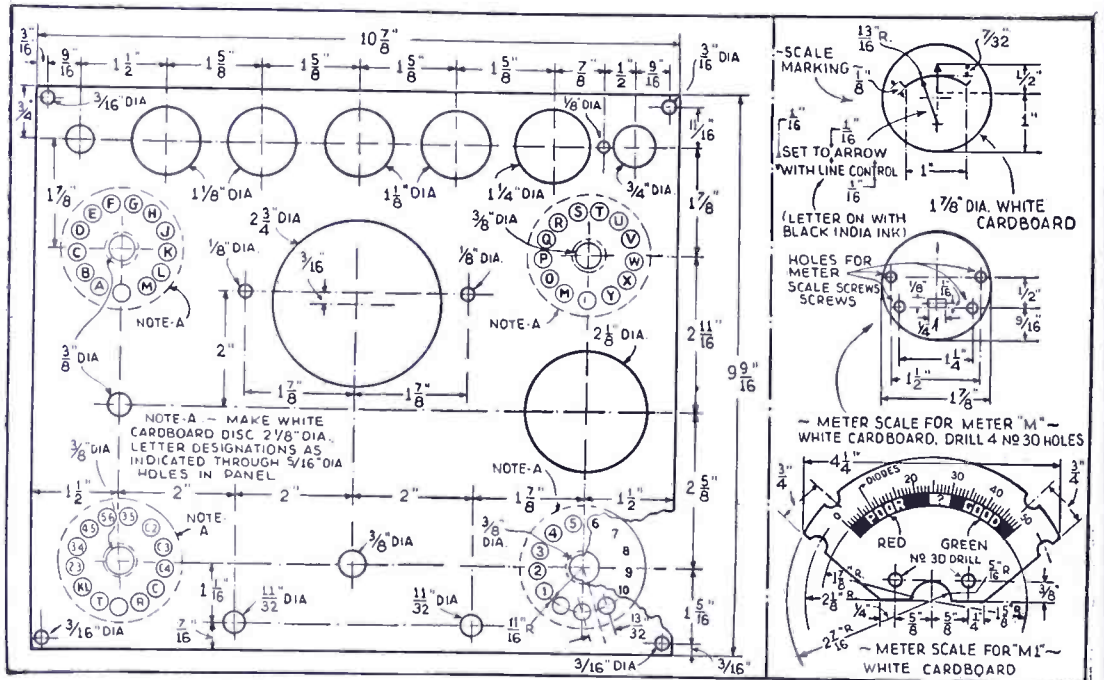

Fig. 2. Panel drilling and marking layout and meter scale markings.

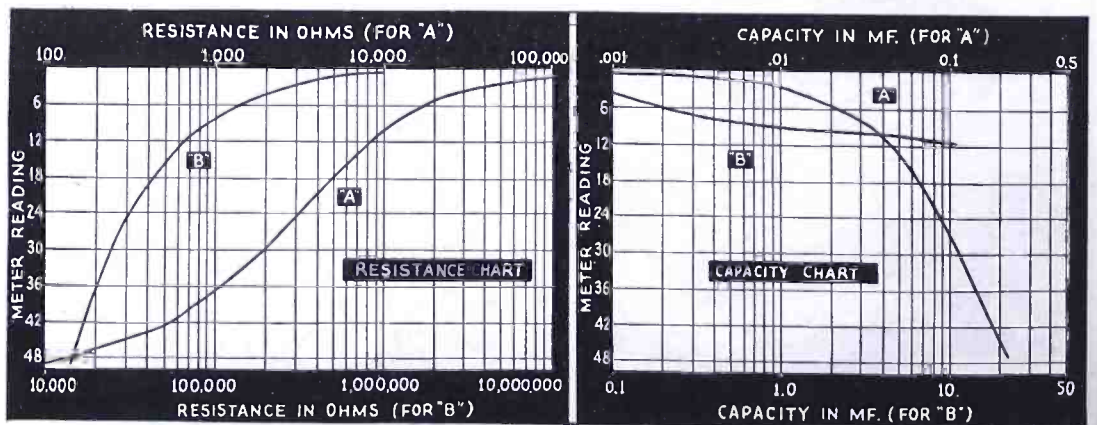

Fig. 3. Charts for using the tester for resistance and capacity measurements.

Please Say That You Saw It in RADIO-CRAFT

"O"; read meter and refer to curve "B" to determine the resistance. Remember, "O" setting of the Shunt control will not be the "O" setting of the knob but will be the "O" setting of the contact arm. Do not force the knob as it will upset the calibration of the instrument for tube testing.

Circuits having a resistance greater than 1 meg. and up to 10 mega. can be checked for continuity by setting the Short Test Switch on "C" and watching the neon tube. A faint glow will be seen even though the resistance of the circuit under test is 3 mega. or more.

Capacity Measurements. Leave the 84-type tube in the socket and set the Short Testing Switch to "C". The Filament Switch will be set at 7, and the Selector Switches at "EN."

Adjust the Line Voltage Control so that the pointer is set at the arrow on the scale. Set the Shunt Control to "O" and connect the test leads to the capacity under test. Electrolytic condensers can be measured but be sure that the red lead or tip-jack connects to the positive side of the condenser.

Read meter and note capacity by referring to the Capacity Chart. Use scale "A" if the value is less than 0.25-mf. Capacities greater than 0.25-mf. will cause the meter pointer to go off scale. Reset the Shunt Control to 90 and check meter reading with the "B" scale on the chart.

Very small values of capacity can be noted by watching the neon lamp. A faint glow around one of the lamp sections indicates a good condenser. An open condenser will give no glow at all and a shorted condenser will cause a bright flash and the meter pointer will go off scale.

From time to time additional charts will be published in *Radio-Craft* so that the tester will be always up-to-date.

# C-D ENGINEERS

## announce

### TYPE TL CAPACITORS

#### DYKANOL IMPREGNATED AND FILLED

The type TL series of high voltage filter condensers were designed for power supplies, high power amplifiers, television circuits, transceivers, etc. Hermetically sealed in round aluminum containers similar to those employed in the construction of electrolytic capacitors. One terminal is insulated, the other grounded. Can be conveniently mounted in either upright or inverted position.

*A post-card will bring you Catalog 135A or see your local jobber.*

**CORNELL-DUBILIER CORPORATION** • 1014 Hamilton Blvd. • So. Plainfield, N. J.



**WRITE TODAY**

D. C. Cap. Working Mfd.	Voltage Size	Cat. No.	List
2	600 2 7/8 x 1 1/2	TL-6020	\$2.25
3	600 4 1/2 x 1 1/2	TL-6030	2.75
4	600 4 1/2 x 1 1/2	TL-6040	3.00
1	1000 2 7/8 x 1 1/2	TL-10010	2.25
2	1000 4 1/2 x 1 1/2	TL-10020	2.75
.5	1500 2 7/8 x 1 1/2	TL-15005	3.00
1	1500 4 1/2 x 1 1/2	TL-15010	3.50



### USEFUL RADIO CIRCUITS

(Continued from page 611)

plugs into socket No. 4.

When using the unit with a 32-V. set having a drain of 50 to 60 W. place a 30-W., 115-V. lamp in socket No. 1 after having removed the fuses. Then place a 15-W., 32-V. lamp in socket No. 3, and the 32-V. D.C. set in socket No. 4. Then start the generator and when the 15-W. lamp lights, start the radio set working. This will dim the lamp very greatly but if a 75-W., 115-V. lamp is inserted into socket No. 2, the voltage will be normal for the radio set. This procedure for 32-V. sets is necessary as the residual magnetism of the generator will not build up under heavy load, and if it did, there would be a heavy voltage surge which might injure the set.

NORMAN E. NELSON

#### HONORABLE MENTION

**A Phono Pickup Coupling Unit.** The circuit here provides a means of connecting any phonograph pickup to an amplifier without loss in quality. By means of the capacity, inductance and resistance, the tone can be varied to suit the characteristics of pickup and amplifier. The coupling unit can also be used effectively as a scratch filter, cutting off the high-frequency response at the correct point for the most pleasing response. The variable condenser should be a mica-insulated unit of the type used for trimming and padding R.F. circuits. See Fig. 6.

DMITRY C. YACOOLEFF  
Athens, Greece

#### HONORABLE MENTION

**Improved Volume Control.** In Stewart-Warner type 950 sets and others using the system of volume control shown at A in Fig. 7, there is a tendency to overload or choke at full volume, with accompanying difficulty in controlling local stations.

By removing the control from the aerial and substituting a new volume-control resistor of 0.1-meg. resistance and a uniform taper (connected in the screen-grid circuit as shown in Fig. 7B) all the above difficulties are removed. If circuit oscillates at 1,300 kc., change R2 to 20,000 ohms; and in case of howl, replace the 0.002-mf. detector plate bypass condenser with one of 0.01-mf. capacity.

EX-STAT SERVICE BENCH

#### HONORABLE MENTION

**Small Set Improvement.** Radio owners who have small sets of the table and A.C.-D.C.

variety which are lacking in selectivity and sensitivity can improve them by connecting a feedback coil in the aerial circuit, as shown in Fig. 8. Make a coil which fits inside of the aerial coil of the set, containing about 10 turns of any convenient size of wire. One end of this coil is connected to the plate of the first tube and the other end is left free. By shifting this coil, smooth operation can be obtained. Be sure to check the alignment of the set after the feedback coil has been inserted in the aerial coil.

ARTHUR PETRU

#### HONORABLE MENTION

**Capacity Coupling.** The use of a condenser as shown in Fig. 9, permits close coupling and good gain at low frequencies, with good selectivity and fair gain on high frequencies in an R.F. coupling circuit.

Further advantages are that a single-winding coil is used, resulting in lower losses and better matching of tuned circuits both at high- and low-frequency ends of the tuning band.

CAL BRAINARD

#### HONORABLE MENTION

**A Novel "B" Power Supply for Ford T Car Sets.** Those who still own model T Ford cars can utilize this novel way of obtaining "B" power for a car radio set. A charging transformer from an old battery charger which has a 20-V. secondary and a 110-V. primary is connected between the magneto plug and the frame of the car, as shown in Fig. 10. The 110-V. winding is connected to the power plug of a "B" power unit of the type using a BH or other rectifier which has no filament.

D. C. DEPUY

#### HONORABLE MENTION

**A Fool-Proof Switch for "Wind" Power Supplies.** Radio set owners who employ the use of a 6-V. storage battery and wind-driven generator to power a 2-V. receiver will welcome the switching arrangement shown in Fig. 11.

A study of the diagram shows that the 8-pole double-throw switch is used as a double-throw switch combined with a 6-pole double-throw unit. The system also allows the battery to be charged as a 6-V. unit, thus preventing injury to the battery. The switch automatically disconnects the generator from the battery whenever the radio set is on, and also disconnects the set from both battery and generator when the set is not being used.

ELMER A. SLAYBAUGH

Please Say That You Saw It in RADIO-CRAFT

### MILLION TUBE TESTER

#### FEATURES

1. Emission
2. Metal Tubes
3. Shorts HOT
4. Leakage HOT
5. Resistance
6. Electrolytics
7. By-Pass Condensers
8. Neon Alignment



MODEL CN  
**\$9.95 NET**

Here's what the Service Men say about the New Million Tube Tester! "Most valuable purchase of test equipment we made during the last year." "It shows up weak tubes better than my expensive tester."

If your jobber cannot supply you—order direct—20% deposit required on C. O. D. orders. Tear out this ad and send it to us NOW for information on complete line.

**MILLION RADIO AND TELEVISION LABORATORIES**  
361 W. SUPERIOR ST., CHICAGO, ILL.

### A NEW IDEA IN IRON-CORE REPLACEMENT COILS

A REMARKABLE development in replacement coils—having adjustable iron cores and adjustable coupling to fill all replacement and construction needs. Four types, antenna, R.F., pre-selector and oscillator fill all requirements. Servicemen, dealers, experimenters and set builders appreciate the flexibility of CARRON COILS.

- Here are Carron Coil features:**
- Compactly designed to fit any set.
  - Can be used with or without shield.
  - Efficient windings with low distributed capacity.
  - Inductance adjustable by more than 25% by use of special iron cores.
  - High or low gain, as required.
  - Coupling between coils adjustable by means of sliding primaries.
  - Oscillator coil can be used with any intermediate frequency.

Complete diagram and instructions are furnished with each Carron Coil.

Write for interesting circular RC-137 showing a complete list of Carron Exact Duplicate Replacement Coils.

**CARRON MANUFACTURING COMPANY**  
415 South Aberdeen Street Chicago, Illinois

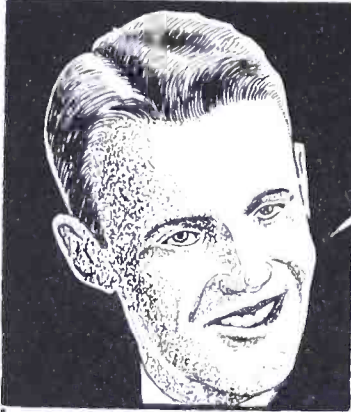

**SURE 'NOUGH, "I USE ONLY GERNSBACK RADIO MANUALS IN MY SERVICE WORK!"**

*For Seven Years We Have Heard Radio Service Men from All Parts of the Country Say This Over and Over Again!*

Since 1930 radio men have bought Gernsback OFFICIAL RADIO SERVICE MANUALS—and today they are being purchased by more and more men for service work. The authentic material, easily accessible diagrams and complete service data make them invaluable to active and alert radio Service Men. *Without a Gernsback Manual with you on a service job, there's time and profit lost.* Your service kit or laboratory is incomplete without all the Gernsback OFFICIAL RADIO SERVICE MANUALS.



**1936 OFFICIAL RADIO SERVICE MANUAL**

Just packed with service data of sets manufactured during 1935, 1936 and 1937. There are SCHEMATIC DIAGRAMS of over 1,500 manufactured receivers showing speaker connections, power-transformer connections, R.F. and I.F. coil connections, phonograph connections, and other information. On all set diagrams, with few exceptions, the I.F. peaks are indicated, also socket connections. Notes on alignment procedure are printed right on diagrams. Faults, symptoms and remedies of all sets are included in the service notes, also for over 80% of the sets you will find OPERATING VOLTAGES. Assembly diagrams show the relationship of separate units to each other. A complete index of TRADE NAMES and their respective manufacturers is to be found in the 1936 Manual. A COMPLETE TUBE CHART includes information on hundreds of tubes. A LARGE CUMULATIVE INDEX contains all sets printed in the 1931, 1932, 1933, 1934, and 1935 Manuals.

1,200 PAGES \* OVER 2,500 ILLUSTRATIONS  
Looseleaf Binder—Stiff, Hard Covers  
Size 9 x 12 Inches \* Price \$7.00

**1935 OFFICIAL RADIO SERVICE MANUAL**

This edition is well noted for containing schematic diagrams and service notes for many older receivers. The volume is printed on a special "Bible Stock" and contains over a thousand pages, still it is only 1 1/4 inches thick. Conveniently rolls to fit into your pocket. Contains a vast amount of information on all-wave receivers, P. A. equipment, midget sets, auto-radio receivers, and test equipment.

OVER 1,000 PAGES \* OVER 3,000 ILLUSTRATIONS  
Looseleaf Binder—Flexible, Leatherette Covers  
Size 9 x 12 Inches \* Price \$7.00

**1934 OFFICIAL RADIO SERVICE MANUAL**

This manual contains values of I.F. transformers on superheterodyne receivers, valuable tube data, complete list of American Broadcast stations, free question and answer service, authentic service material and schematic diagrams.

OVER 400 PAGES \* OVER 2,000 ILLUSTRATIONS  
Looseleaf Binder—Flexible, Leatherette Covers  
Size 9 x 12 Inches \* Price \$3.50

**1933 OFFICIAL RADIO SERVICE MANUAL**

The 1933 Manual features pictorial views of hundreds of commercial receivers with additional schematic diagrams, location of parts on chassis, values of intermediate frequencies, values of resistors and condensers and other valuable information for Service Men.

OVER 700 PAGES \* OVER 2,000 ILLUSTRATIONS  
Looseleaf Binder—Flexible, Leatherette Covers  
Size 9 x 12 Inches \* Price \$5.00

**OFFICIAL RADIO SERVICE HANDBOOK**

Here's the sensational new book on servicing. It is edited by J. T. Bernsley, well-known radio service authority. It covers over 500 radio topics and gives a complete description of the "Magic Eye." Contains a special section of 250 pages of Operating Notes. The book covers: Circuit Theory and Analysis; Modern Servicing and Test Equipment; Practical Short-cuts in Trouble Shooting and Repairs; Specialized Receiver and Installation Data; Modernization and Conversion Data; Social and Economic Problems of Service Men; and Operating Notes and Practical Data Listings.

OVER 1,000 PAGES \* OVER 1,000 ILLUSTRATIONS  
Beautiful Linen, Gold-Stamped Cover  
Size 6 x 9 Inches \* Price \$4.00

**1932 OFFICIAL RADIO SERVICE MANUAL**

Here is the volume which shows a step-by-step analysis of how to service any receiver. It is one of the early editions and covers many old sets.

OVER 1,000 PAGES \* OVER 2,000 ILLUSTRATIONS  
Looseleaf Binder, Flexible Covers  
Size 9 x 12 Inches \* Price \$5.00

**1931 OFFICIAL RADIO SERVICE MANUAL**

This is the first complete radio Manual published. It contains a comprehensive course for servicing radio sets. This course is invaluable not only to Service Men, but everyone interested in radio.

OVER 650 PAGES (Including Supplements)  
OVER 1,500 ILLUSTRATIONS  
Looseleaf Binder—Flexible, Leatherette Covers  
Size 9 x 12 Inches \* Price \$4.50

**1935 OFFICIAL AUTO-RADIO SERVICE MANUAL**

OVER 240 PAGES \* OVER 500 ILLUSTRATIONS  
Looseleaf Binder—Flexible, Leatherette Covers  
Size 9 x 12 Inches \* Price \$2.50

**1933 OFFICIAL AUTO-RADIO SERVICE MANUAL**

OVER 250 PAGES \* OVER 500 ILLUSTRATIONS  
Looseleaf Binder—Flexible Leatherette Covers  
Size 9 x 12 Inches \* Price \$2.50

**OVER 90,000 GERNSBACK OFFICIAL RADIO SERVICE MANUALS AND HANDBOOKS IN USE TODAY!**

Clip Coupon and Mail to RADCRAFT PUBLICATIONS, INC., 99 HUDSON ST., NEW YORK, N. Y.

<b>RADCRAFT PUBLICATIONS, INC., 99 Hudson Street, New York, N. Y.</b>		<b>RC-437</b>
Gentlemen: Enclosed you will find my remittance of \$..... for which you are to send me, POSTPAID, the Book or Manual which I have indicated at the right by a cross (x) in the panel.		
Name .....		<input type="checkbox"/> 1936 Official Radio Service Manual @ \$7.00
Address .....		<input type="checkbox"/> 1935 Official Radio Service Manual @ \$7.00
City .....	State .....	<input type="checkbox"/> 1934 Official Radio Service Manual @ \$3.50
(Send remittance in form of check or money order; register your letter if you send cash or unused U. S. Postage Stamps).		
		<input type="checkbox"/> 1933 Official Radio Service Manual @ \$5.00
		<input type="checkbox"/> 1932 Official Radio Service Manual @ \$5.00
		<input type="checkbox"/> 1931 Official Radio Service Manual @ \$4.50 (Including Supplements)
		<input type="checkbox"/> 1935 Official Auto-Radio Service Manual @ \$2.50
		<input type="checkbox"/> 1933 Official Auto-Radio Service Manual @ \$2.50
		<input type="checkbox"/> Official Radio Service Handbook @ \$4.00

Please Say That You Saw It in RADIO-CRAFT



## "ELECTRIC EYES" SEE ALL—DO ALL

(Continued from page 591)

to illustrate the possibility of utilizing photocell equipment as a robot nostril. (Fig. L)

(To guard against the presence of lethal, odorless carbon monoxide gas—a concentration of more than 6 parts in 10,000 parts of air is unsafe—in manholes the present practice by telephone companies is to lower into the suspected manhole a cotton-covered glass ampoule containing palladium chloride solution. The ampoule is broken, lowered into the manhole, and 10 minutes later raised and compared visually for color against a chart graduated from straw color to gray. It seems to this writer that a photocell color meter, with built-in ampoule holder and both to be lowered together, would more accurately and quickly indicate the tint and rate of color change, in a few seconds after the ampoule was broken; this would appear to be a real money-saver inasmuch as, by the old method, 30 minutes of a 3-person crew is lost, waiting for the tint-check to be completed. —Author)

**A "Keen" Razorblade Tester Utilizes Photocells.** Razor blades are tested at the Gillette Safety Razor Co.'s factory for sharpness, imperfections and accuracy of alignment, among other tests, by means of photoelectric equipment. The old method of cutting a human hair to determine sharpness has been relegated to the scrap heap in U. S. Patent No. 2,027,595. (Fig. N)

### PHOTOGRAPHIC USES OF P. E. CELLS

**Photocell Controls Camera Aperture.** No less a personage than Dr. Albert Einstein is the inventor, in collaboration with Dr. Gustav Bucky, of the method, described in U. S. Patent No. 2,058,562, of automatically controlling by photoelectric means the amount of light admitted to the lens system of a camera; this is, speaking broadly, the aperture or "stop" setting.

A vane, graduated from transparent to opaque, is arranged like a millivoltmeter movement to swing across the lens opening; the exact position this swinging vane assumes—that is, the amount of light it will permit to pass, is a function of the amount of light picked up by a light-sensitive cell the output of which is directly connected to the movement that actuates the vane. Thus, if the surrounding light is of low intensity the vane swings until the transparent section is in front of the lens opening; in bright sunlight, on the other hand, the vane will swing until a more opaque section of the vane is positioned in front of the lens opening. (Fig. J)

**Photocell Controls Camera Shutter Speed.** That indefatigable worker in the electronics field, F. H. Shepard, Jr., last month contributed to the photographic fraternity an ingenious photoelectric device for controlling camera shutter speed in direct proportion to the total amount of illumination available. (Fig. I)

**Photocell Focuses Camera.** By utilizing a photoelectric cell sensitive only to, for instance, infra-red rays which do not ordinarily affect the average camera film, a method is presented in U. S. Patent No. 1,866,581 for automatically focusing a camera. Photograph fans who have waxed profane at their occasional, or perhaps frequent failures to properly focus their cameras, resulting in fuzzy and perhaps indistinguishable images, will welcome this idea. The actuation of the photocell is based on a means of projecting an exciting beam from a point on the camera, to the subject, and back to a photocell at a second point on the camera. (Fig. K)

**Built-on Electronic Exposure Meter.** Photographers are familiar with the currently available light-intensity meters which utilize a photoelectric cell to indicate relative values of lighting. Few, however, are aware that an exposure meter of this type is now being incorporated along one side of new-type Zeiss-Ikon cameras just announced in France; and atop the Zeiss-Contax III (illustrated) in America. (Fig. G)

### MISCELLANEOUS APPLICATIONS

**"Electric Eyes" Police Uncle Sam's New "Free Port" Against Smugglers.** At Stapleton, Staten Island, is located the recently-opened "free port"—a zone wherein commodities from abroad may be received, handled, packed, graded, assorted, assembled and reshipped without becoming subject to duty—first of its kind in the United States. Photoelectric equipment is scheduled to be an essential policing agency in preventing misuse of the international trade conveniences this New York port affords. Only the criss-crossing lightbeams overcame the War Department's objections to previously-suggested methods which were vetoed as being menaces to navigation. Contracts for the P. E. installation have been let.

The lightbeams will skim the surface of the water from a control station at the extremity of the central dock to photocells in buoys fixed to the ends of the docks at either extremity. These buoys are to be protected against ice and debris by crib-work; and will rise and fall with the tide.

A signal system will flash warning to the headquarters of the free zone if the beam is broken. Even a swimmer crossing the rays will break them. (Fig. H)

**Photocells Establish Brightness of 100,000 Stars.** "Twinkle, twinkle, little star—" reads the nursery rhyme; but savants at Columbia University, New York, are prepared to tell you just how much the stars—25,000 of them—really do twinkle. (Soon, 75,000 more stars will be similarly cataloged.)

Photographic plates, exposed and developed at Yale University, are now available which carry dots, of varying degrees of density grading from gray to practically black, which represent various stars from 4th-magnitude (visible by the naked eye) brightness to 9th-magnitude intensity. The trick is to intercept with these dots a beam of intense light trained on a photocell; the amount of light each dot intercepts is indicated by a reduction in the photocell's meter reading and this reduction may be taken as an "index of intensity" (of the star). (Fig. E)

Having thus established for the first time a quantitative figure for a star's brightness, and knowing its type (spectrotypes have been made by Harvard) and movement (angular-displacement data have been obtained by Yale), astronomers can now obtain a comprehension of a star's distance.

**"Electric Hand" for Telescopes.** A control more delicate than a woman's little finger and as powerful and positive in its action as a draw-bridge mechanism is the new photoelectric-type automatic guider for telescopes.

Star gazing, and especially time-exposure photography, usually demands continual readjustments. But at Mt. Wilson Observatory, for instance, electronic means have been found for automatically keeping the tons-weight, 60-in. reflecting telescope trained on a particular star.

(Continued on page 632)

# The Delicate Balance of "High-Fi" Sets

EASILY ADJUSTED WITH

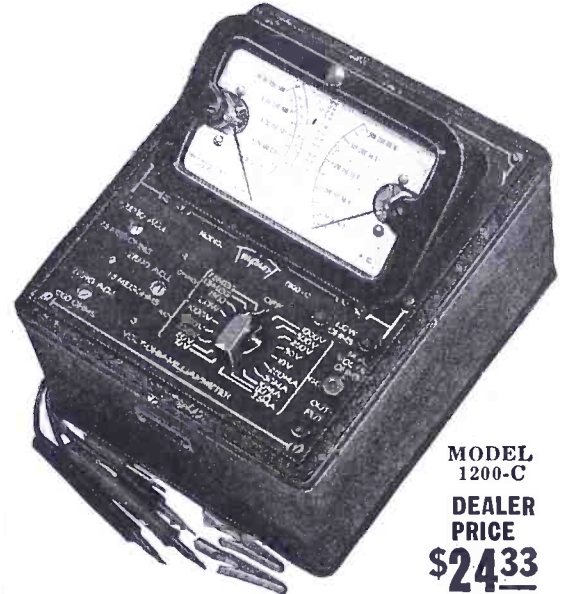

MODEL 1200-C  
DEALER PRICE \$24.33

## Model 1200 C VOLT - OHM - MILLIAMMETER

- 5000 Ohms Per Volt D.C.
- Resistance Readings to 7.5 Megohms
- For all Radio Measurements Not Requiring a No Current Draw Vacuum Tube Voltmeter

The delicate balance of high fidelity sets requires servicing instruments capable of measuring high resistance and all voltages accurately.

Model 1200-C Volt-Ohm-Milliammeter has self-contained power for readings to 7.5 Megohms. The D.C. voltage readings are at 5000 ohms per volt enabling you to read accurately the voltages of low power.

Has two separate instruments, A.C. and D.C., in twin case. Ohms Scales separately adjusted.

Scale Reads: A.C. and D.C. 10-50-250-500-1000 Volts, the D.C. is at 5000 Ohms per volt; 250 Microamperes; 1-10-50-250 Milliamperes; 1/2 to 500 Ohms, 1500 Ohms, 1.5 and 7.5 Megohms.

### A TRIPLETT MASTER UNIT

See Your Jobber

Write for Catalog



The Triplet Electrical Instrument Co.  
164 Harmon Ave., Bluffton, Ohio

Without obligation please send me more information on ..... Model 1200-C; ..... Complete Triplet Master Unit Line.

Name .....

Address .....

City ..... State.....

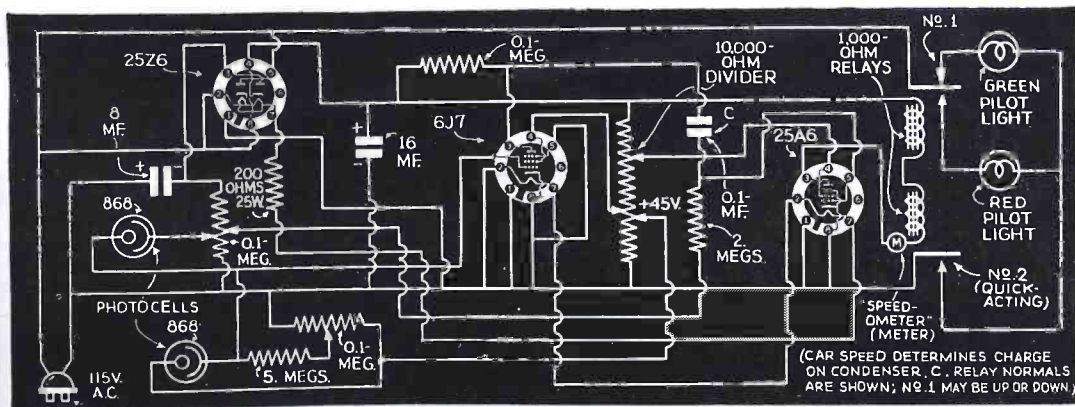
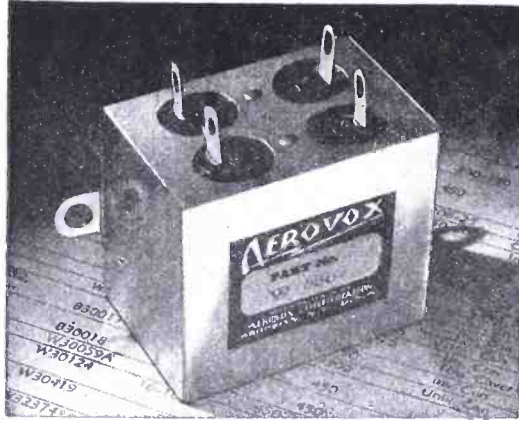

Fig. 1. Schematic "demonstration" circuit of the speed indicator shown on the cover of this magazine.

Please Say That You Saw It in RADIO-CRAFT

## BUILD THIS "2-IN-1" EMERGENCY RADIO SET

(Continued from page 602)



# Matched!

- ★ Exact-duplicate condenser replacements for any standard make of set.
- ★ Precisely matched electrically, mechanically, visually.
- ★ FIT right, LOOK right, WORK right—the only way to do a real servicing job.
- ★ Yet they cost no more than a makeshift collection of standard condensers—usually lots less for material and labor.

**Send for CATALOG:** Contains several pages of exact-duplicate condenser listings, as well as other condensers and resistors of the complete AEROVOX line.



**WHIZ Electric Tool**  
 DRILLS, GRINDS, POLISHES, SHARPENS, SANDS, SAWS, CARVES — easily, quickly

**POWERFUL - SPEEDY DEPENDABLE**  
 ONLY \$6.95 POSTPAID  
 A.C.-D.C. motor. Full size chuck, up to 1/4" capacity. Self enclosed fan prevents overheating. Ball-bearing thrust. Pistol grip with thumb switch. Light weight die cast housing.

**FREE** - accessory outfit, including set of drills, mounted grinder, sanding discs, mandrel, etc. sent free with each WHIZ tool ordered now. Complete outfit for only \$6.95 postpaid.

**PARAMOUNT PRODUCTS CO.**  
 Dept. J 245 Broadway, New York

# CRYSTAL HEAD PHONES

# SOUND CELL MICROPHONES

Information on request  
**THE BRUSH DEVELOPMENT CO.**  
 3312 PERKINS AVE • CLEVELAND, OHIO

**RADIOS . . . SAVE 50%**  
 30 DAYS TRIAL  
 Discounts up to 50% on NEW 1937 Zephyr World-Wide, all-electric, battery and auto radios with all latest improved features. **MONEY-BACK GUARANTEE.** Write for details of our money-making Agent-User Plan and FREE 1937 Catalogue.  
**ZEPHYR RADIO COMPANY**  
 13141 Hamilton Ave. Detroit, Michigan

different lengths of antennas. The antenna may be a dangling wire of from 25 to 75 ft. Wherever possible a good ground connection should be employed. If the set is used on a boat a counterpoise should be used in place of the ground. This can be made by attaching a wire to a metal plate trailing in the water.

The set was not designed to be a distance-getter but has considerable range nevertheless—500 miles not being a too conservative figure. Of course earphones only must be used.

If the circuit oscillates uncontrollably when finished it may be necessary to remove several turns of wire from the primary winding. Remove these turns 2 or 3 at a time until the circuit can be made to go into and out of oscillation smoothly.

And, if the set is to be really an emergency set then the batteries should be kept fresh at all times. If not used the batteries have a normal "shelf life" of about 1 year. Hence they should be replaced once a year.

The set may be operated with no "B" battery at all, for emergency service within a few miles of a transmitter, though much better results are obtained when some "B" potential is used. The "B" battery may vary from a single dry cell, connected as shown in Fig. 2B, to a pair of 22½ V. "B" batteries connected as Fig. 2E shows. The loudest signals and best sensitivity are, of course, obtained with the latter.

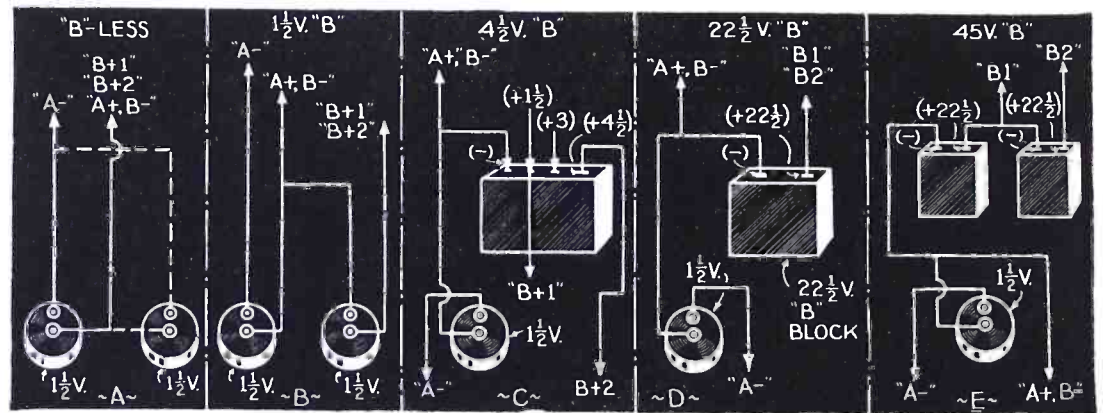
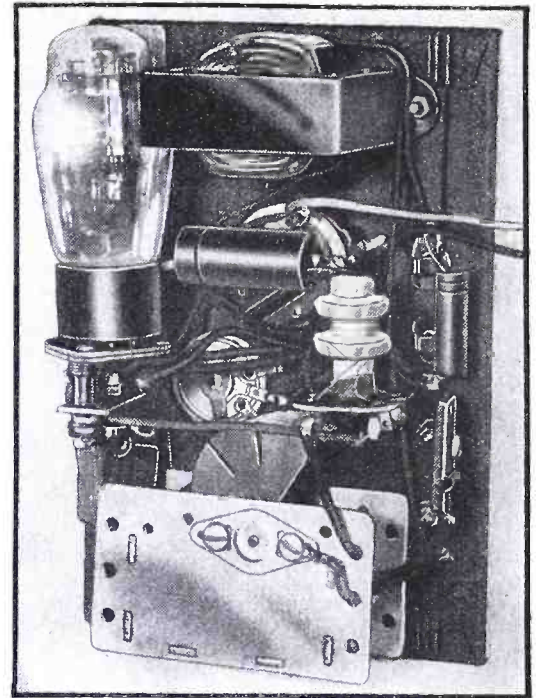

Fig. 2. Battery connections for "emergency" and "normal" operation. Fig. B, upper-right. Panel rear-view.

## "ELECTRIC EYES" SEE ALL—DO ALL

(Continued from page 631)

Heretofore only bright stars radiated sufficient energy to actuate the mechanism which was limited in its sensitivity by previously-available types of photocells. By the use of the new Zworykin super-photocell or multiplier tube, however, Drs. Whitford and Kron have extended the sensitivity to include stars of the 8th magnitude (invisible to the eye).

Light from the star, divided by a mirrored wedge, passes through a "light chopper," a rotating shutter, which turns 10 times per sec. and allows first one beam then the other to shine upon a multiplier tube which changes the light energy into electrical energy and raises it in 10 steps to more than a million times greater voltage. (Fig. F)

The differential current then produced, if the telescope is not correctly aimed, is further amplified and fed to a correcting motor.

**Photoelectric Remote Detonator.** Of interest to those who may not have noticed its publication is U. S. Patent No. 2,015,670, which discloses a means of detonating remote explosive bombs by means of light rays. The idea is to follow with a searchlight the path of an explosive-laden torpedo as it approaches an enemy craft during wartime. The shadow that results when the torpedo passes underneath the vessel causes the light-sensitive cell built into the torpedo to be deenergized and in turn, by actuating a relay, detonate the war head of the torpedo. (Fig. D)

### Photocells "Eye" Bathing Streamlined Trolleys.

According to *Coyne Graduate News*, heretofore, a small army of men at the car-barn would swarm like a lot of bees over each street-car as it arrived and give it a workout. But that was yesterday. Today, the streamlined trolley-car breaks a beam of light, directed at a photocell, that starts water pouring onto the car and causes rotating scrubbing-brushes to go over

its surface. In 55 seconds the shower and rub-down is completed! (Fig. C)

## "WHITE" IS A RAINBOW OF COLORS!

(Continued from page 592)

This photocell, be it noted, is a patented type, designed by the writers, of exceptional sensitivity over the entire color range. The meter used is a 0-200 microampere instrument with the scale marked 0-750 for easy determination of the percentage (by having all zeros or 5s to add and thus obtain the divisions easily); the readings are sensitive to less than 2 millionths of an ampere without amplification (which would introduce errors greater than the sample being tested), and in addition has available 10 scale readings as afforded by the multiplier switch that connects into the circuit, in series, resistors of requisite value which extend the readings to 7,500 points.

If dull materials (blotting paper, liquids, dark materials, etc.) are the ones encountered with greatest frequency in utilizing the color meter a single exciter lamp is used, as shown in Fig. 1A. If glossy materials (silks, ceramics, glass, etc.) are to be accurately checked the 2-lamp design shown in Fig. 1B is to be preferred in order that only true color and diffuse reflection will be indicated.

In either event the beam of light from the exciter lamp does not shine directly on the photocell but reaches it only after being reflected, at an angle of 90 deg., from the surface under test and then color-filtered. The sample of material to be color-tested unless special provisions are made should be about 2 ins. in dia. Since the sample is completely covered by the instrument daylight cannot enter and cause erroneous readings.

Part II will continue this interesting explanation, giving a number of applications of the reflection-type color meter.

Our Information Bureau will gladly supply the names and addresses of any manufacturers whose products are mentioned in *Radio-Craft*.

Please Say That You Saw It in RADIO-CRAFT

# IMPROVEMENTS IN THE "12-TUBE HI-FI BROADCAST RECEIVER"

(Continued from page 603)

distortion. With reverse feed-back the tubes will deliver 25 W. with only a small fraction of this distortion!

The output transformer for the 6L6 tubes has a primary plate-to-plate impedance of 6,600 ohms and 2 low-impedance secondaries, one 500/125 ohms, the other 15/7.5/5/3.75/1.25 ohms.

Some changes have been made in the power supply unit and in the voltage divider in the set in order to permit the 6L6 tubes to be operated with 400 V. on their plates.

It is necessary to secure a power transformer with a high-voltage secondary of 500-0-500 V. instead of the 375-0-80-375 V. winding in the old transformer. It should be capable of full voltage output at 220 ma. drain (D.C.).

The A.F. transformers used are precision high-grade equipment with a frequency response flat within 1/2 db. from 30 to 16,000 cycles.

- sliders, 25,000 ohms, 25 W.;
- \*One wire-wound resistor with 2 adjustable sliders, 2,000 ohms, 25 W.;
- \*One wire-wound resistor with 2 adjustable sliders, 15,000 ohms, 25 W.;
- \*Assortment of insulated metallized fixed resistors, 1/2-W. (see diagram for values);
- \*One audio transformer, precision type, single plate to push-pull grids, T1;
- \*One deluxe output transformer, push-pull 6L6 tubes to loudspeaker, type D-106B;
- \*One choke, 60 hy., 15 ma., type HC-117, Ch.5; Two RCA Radiotron 6L6 beam power tubes.
- \*Names and addresses of manufacturers will be sent upon receipt of a stamped, self-addressed envelope.

## LIST OF PARTS

- (Additional material; for original List of Parts, see RADIO-CRAFT, Feb. and Mar. 1936.)
- One Cornell-Dubilier oil-filled paper condenser, 4 mf., 600 V., C1;
  - One Cornell-Dubilier paper cond., 2 mf., 400 V.;
  - Two Cornell-Dubilier paper cond., 0.5-mf., 600 V.;
  - Four Cornell-Dubilier electrolytic condensers, 20 mf., 50 V.;
  - Four Cornell-Dubilier electrolytic cond., 4 mf., 425 V.;
  - One Cornell-Dubilier electrolytic cond., 8 mf., 425-V.;
  - One Cornell-Dubilier paper cond., 2 mf., 400 V.;
  - \*One insulated resistor, 0.25-meg., 1 W.;
  - \*One wire-wound resistor with 2 adjustable

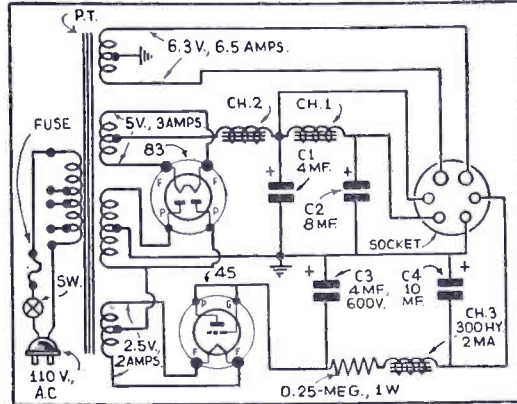

The revised circuit of the power supply unit.

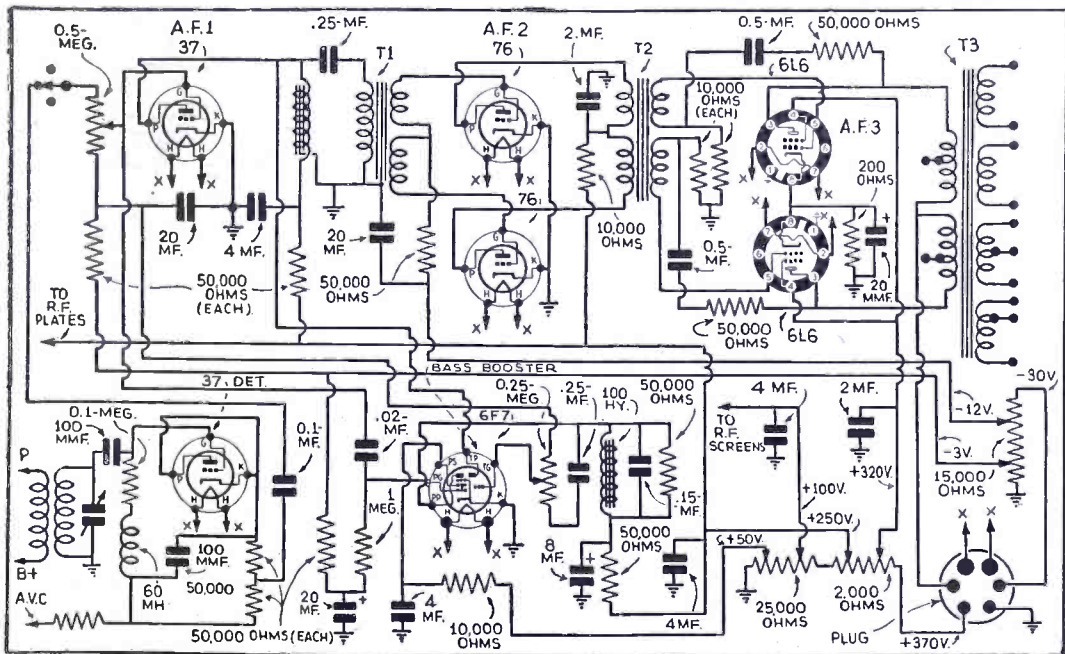

The amplifier circuit changed according to the details given above.

## QUESTIONS AND ANSWERS ABOUT ELECTRONIC MUSIC

(Continued from page 593)

several taps so that the transformer manufacturer will mark them for different impedances.

You need to know only 8 impedances for 8 windings: one winding for the first octave; one winding for the second octave, etc. Impedance must be checked while the shaft carries phonic wheels of all As, so that the fourth A must have 440 cycles, and all magnets must deliver the same amount of energy, while the number of turns is more for low As and less for high As.

It is advisable to make one shaft with 7 or 8 phonic wheels on it in consecutively doubling numbers of teeth. The cores of the magnets must be at least 1/4-in. to 5/16-in. dia., and not less than 2 1/4 ins. long. The tone wheels must be 1/16- to 1/8-in. thick.

I do not think much of a bevel gear drive, especially when the ratios contain errors. There is no advantage in using a Thomas gear drive, patent No. 1,156,329, "invented" by Hammond.

I suggest you use a gear train made of composition similar to bakelite or fibre, consisting of 24 gears, 1/4-in. face, pitch 48, these gears placed on 12 shafts, with a 196-tooth gear meshed with a 185-tooth gear, and on the same shaft as the 185-tooth gear, the 196-tooth gear meshed with a 185-tooth gear on another shaft, and so on.

By this arrangement, frequencies have no

error, since the speed of the shafts progresses geometrically at a ratio of  $12\sqrt{2}:1$ . However, for your purpose, I believe that pulleys and belts are best.

Dozens of flexible joints are unnecessary, as you probably find the necessity for electrical filters to eliminate parasitic frequencies of the revolving shafts. (Hammond uses 45 filters).

A diagram of one type of synthesizer, which can be altered to suit individual needs, is shown in Fig. 1. This type of synthesizer is used by Mr. Eremeeff. Be sure that the windings of the magnets are always open, so that you do not get trouble from feedback. Shield the magnets.

For synthesizing

	First key	Second key	
C <sup>0</sup> Fundamental	32.70	C# <sup>0</sup> Fundamental	34.64
C <sup>1</sup> Second	65.40	C# <sup>1</sup> Second	69.29
G <sup>1</sup> Third	97.99	G# <sup>1</sup> Third	103.82
C <sup>2</sup> Fourth	130.81	C# <sup>2</sup> Fourth	138.59
E <sup>2</sup> Fifth	164.81	F <sup>2</sup> Fifth	174.61
G <sup>2</sup> Sixth	195.77	G# <sup>2</sup> Sixth	207.65
C <sup>3</sup> Eighth	261.62	C# <sup>3</sup> Eighth	277.18

Use the same procedure for all other keys. Frequencies for partials have a slight error since they are taken from a tempered musical scale, which is satisfactory for this case.

Please Say That You Saw It in RADIO-CRAFT

# MONEY IN YOUR POCKET!



## SYLVANIA'S FAMOUS TECHNICAL MANUAL IS A PROFIT-MAKER! PUT IT TO WORK FOR YOU!

On every job, you'll find it comes in handy — solving problems, answering questions, saving you time to get going on the next call. It's worth many a dollar in extra profits... and it's yours for 15¢!

Handy pocket size. 184 pages. Lists 193 tube types, with important circuit application information on each. Tells all about glass, metal and "G" type tubes, including those for Majestic receivers... and full information on SYLVANIA "Ballast Tubes".

Don't just wish you had it! Get it now! Clip the coupon and mail it today!

Hygrade Sylvania Corporation, makers of Sylvania Radio Tubes and Hygrade Lamps. Factories at Emporium, Pa.; Salem, Mass.; and St. Mary's, Pa.

# SYLVANIA

The Set-Tested Radio Tubes

**HYGRADE SYLVANIA CORP. EMPORIUM, PA. RC-47**

Please send me the Sylvania Technical Manual. I enclose 15¢ in stamps or coin.

Name .....

Address .....

City ..... State .....

# THE MOST FLEXIBLE POCKET MULTITESTER YOU CAN BUY

**DEPENDABLE  
MODEL 408-602  
DETACHABLE  
COMBINATION  
AC-DC TESTER**



and only  
**\$13.90** complete

THE ONLY POCKET-SIZE  
MULTITESTER HAVING

- A.C. volts 1-5-50-500-1000; D.C. 5-50-500-1000
- 2,000 ohm per volt sensitivity
- 3 range self-contained ohmmeter 1,000,000-50,000-500 ohms
- 17 meters in 1
- No test leads required for balancing
- 550 microamp; 5 amp; 5-50-500 mills
- Low ohm reads 5 ohms at center scale 1/10 ohm for 1st 10 division—low current drain.

Available separately: D.C. multitester 408, \$9.95; A.C. converter 602, \$3.95

See your jobber  
Write to Dept. C for catalog

## RADIO CITY PRODUCTS CO.

★ 88 PARK PLACE NEW YORK CITY "DEPEND ON DEPENDABLE" ★

### SPECIAL CONDENSER OFFER TO RADIO MEN!

We want every radio man to prove conclusively to himself the many advantages to be found in ILLINOIS DRY ELECTROLYTIC & PAPER CONDENSERS. Skilled engineering and the finest of materials have been combined to produce a quality line of condensers at lower cost. ALL ILLINOIS CONDENSERS are designed to withstand temperature extremes, humidity and eliminate costly re-servicing. Every ILLINOIS CONDENSER is unconditionally guaranteed for a period of one year! In order to prove their worth, we will for a limited time only, send post-paid our 8 MFD, 550 peak voltage condenser, upon receipt of your jobber's name and address, and 15c in stamps or coin to cover cost of handling, etc. Send for your trial condenser today and receive illustrated catalog sheet and price list.

### ILLINOIS CONDENSER COMPANY

3252 WEST NORTH AVENUE CHICAGO, ILLINOIS

### Headset ADAPTER Kit

Now available a headset adapter kit providing "QUIET RADIO" reception with the minimum of expense and installation work. Ideal for the bedside radio, providing reception with the least disturbance to others—the short wave fan will find it a great boon—and the hard of hearing will find a new world of sound.

Write today for complete information.

### TRIMM RADIO MFG. CO.

1770 W. Berteau Ave., Chicago, Ill.

### MAKE A RADIO COLOR ORGAN



with the 1/4-Watt Argon Glow Lamps colored with Stroblite Fluorescent Colors. In any color.....75c each. Four Bulbs are used in Color Organ, Blue, Green, Orange, Red. Stroblite Fluorescent Colors....\$1.00 per ounce

STROBLITE CO. 35 W. 52nd St. New York

**FREE 1937 RADIO CATALOG**

**SAVE up to 50%**

R. C. A., GENERAL ELECTRIC PHILCO, ZENITH and Other Standard makes. Electric and farm radios as low as \$6.75. All new—perfect—guaranteed. Write for catalog and agents discount sheet. Do it today!

BUY WHOLESALE DIRECT

MODELLS 58-D Cortlandt Street, N.Y. CITY Est. 1889

### P.S.: "HE MADE THE SALE!"

(Continued from page 610)

of his statement, softly reminded him in answer to his latter question that he still owed us 2 bucks, and then went about getting the whole story from him. Like the Scotchman after winning his first bet on the horses, Johnny, it developed, had sold his first P.A. job and was asking: "How long has this been going on?"

Up to the time of this first sale, he had gone along with his radio trade, a victim of inertia. Public Address, to him, was something that smacked of intensive sales work, large investments and excessive labor—he just couldn't get excited about it. One day, as he put it, it came to him as in a dream (that, among other things). He really hit on an idea. He would make it his business to watch for places that used a conventional receiver or phono-radio combination for dancing or entertainment. As a move to enter the P.A. field, it amounted to nothing more than first trying the water with your large toe. But it worked.

A church affair he attended produced the first prospect. Music for the dancers was supplied by a radio receiver of average power. Needless to add, it possessed shortcomings for the role for which it had been drafted. It was so terrible it was ideal—for Johnny. His next move was not bad at all; he constructed a fairish-sized amplifier, obtained a pair of better-quality speakers, microphone and stand, turntable and pickup in a carrying case and the usual wire and cabling.

The amplifier put 15 W. into a 500-ohm line, had 3 inputs—1 high-and 2 low-gain—mixer-fader controls, tone control and variable output impedances. The tube line-up comprised a 6C6, 76, 6A6, two 6B5s and an 83V rectifier. Field current supply fed 16 W. to 10,000 ohms. An unusually high gain, 140 db. at 5 meg., permitted the direct use of crystal or velocity mike.

Choosing the speakers was quite a problem; maximum portability was desired, money for pure sales promotion was scarce, but it was darn important that they put out to the complete satisfaction of a prospect. A pair of good radio-set speakers answered all three factors very nicely. Baffling and carting them, fell in one swoop by obtaining a conventional carrying case which split into 2 sections. The case also provided space for the amplifier and speaker cable. And it looked mighty clean and impressive.

The phono-motor, turntable and pickup likewise went into a portable case. The microphone presented no problem whatsoever—it was simply a matter of buying one, regardless of the pain involved. The pain hurt to the extent of a crystal sound cell.

Then came the big day. Empty bottles, hairpins and old Saturday Evening Posts were swept ruthlessly from the back of the car and the system neatly stowed away. Off he went feeling like a Forty-Niner heading for the gold fields—and just as broke.

His church was the first objective. Upon arriving there, he went briskly about setting up the outfit in the social room. That much credit must be given him—for nerve; if he had first offered to demonstrate, he, doubtless, would have been hemmed and hawed out (of it), but his way certainly stole a march on that ol' debbil "Sales Resistance." When the set-up was perking to his satisfaction, he called in the minister and did his stuff. He pulled all the mike-phono fading and mixing stunts, played organ music (he had brought along a few organ recordings), and taught the minister mike technique (of which Johnny knew nothing).

That clinched it. The church board was called at once and came arunning. (Here is where the Elk sale begins to creep in.) The performance was repeated with each member taking his turn at the mike, and, boy, oh, boy, there's nothing like letting a member of a church board take a strangle hold on a full-grown microphone. The installation was as good as in, half-way through Lincoln's Gettysburg Address which Mister Spolding was pouring into the defenseless sound cell—with gestures.

After that episode was over, the system was taken into the church for a pulpit demonstration. Here the minister regained some of the flower of his youth and under the stress of novelty delivered his next Sunday's sermon to the impatient board members who stood in line in the aisle awaiting their turn to go it again.

The system was sold.  
Now for the Elk's sale. You guessed it—the  
(Continued on page 635)

Please Say That You Saw It in RADIO-CRAFT

### HAVE YOU SOME SPARE ROOM

a basement or garage where you can do light work? We can offer you a profitable proposition casting 5 and 10c Novelties, Ashtrays, Toy Automobiles, etc. as Branch Manufacturer for firm of many years standing. No experience necessary as we furnish full instructions with moulds. If interested in devoting your spare or full time to profitable work and you mean strictly business write AT ONCE for full details as we are now closing 1937 arrangements for supply of our goods.

**METAL CAST PRODUCTS CO.**  
Dept. 26, 1696 Boston Road, New York, N. Y.

On broadcast as well as shortwave frequencies, in any location, you can eliminate "man-made" static with

**CORWICO**

**NOISE-MASTER**  
ALL-WAVE ANTENNA

Send for complete literature.

**CORNISH WIRE CO., 30 CHURCH STREET, NEW YORK CITY**

### SPECIAL AALLOY PARTS

are used and specified in

**RADIO-CRAFT 1937 TELEVISION RECEIVER**

(1) Aalloy special transformer type 621-1A **\$7.20**

(4) Aalloy special 100 M.A. filter chokes type 797 **NET PRICE**

Order this special equipment today!

**AALLOY TRANSFORMER CO., Inc., 135R Liberty St., N.Y. City**

**"HAM" SPECIAL** Standard Teleplex

A highly efficient code teacher using heavy specially prepared waxed paper tape, having two rows of perforations. Write for Free folder A4. We are the originators of this type instrument

Instrument with tapes prepared by expert and complete course; all for **\$11.95**. Without Oscillator. **72-76 Cortlandt St., N. Y. C.**

### COMPLETE ELECTRIC PLANTS

ONAN ALTERNATING CURRENT PLANTS furnish same as city current anywhere. Operate on gasoline. Run Radio, Water System, Refrigerator, all Appliances. Complete, ready to run.

**SIZES 350 WATTS UP**

Easy to install. Available from stock. For Farms, Camps, Commercial use. Sizes for any purpose. Write for details.

**D. W. ONAN & SONS**  
585 Royalston Ave. Minneapolis, Minn

### NEW FIELD FOR RADIO MEN

Sell our complete line of 16 MM and 35 MM motion picture equipment for theatres, institutions, clubs and home use. We have everything. Tremendous field; liberal profits. Write TODAY.

**S.O.S. CORP.** 636-RA Eleventh Ave., N.Y.C. CABLE—SOSOUND, N.Y.

### RADIO MEN! GRAFOLINE

Insures correct permanent repairs for all air exposed contacts and wherever dust and dirt affect moving parts. Ideal for all-wave switches, wire wound volume controls, etc. Easy to apply, insures longer wear for parts, lubricates electric motors, vacuum cleaners, etc. Full sized bottle 35c from your Radio Parts Jobber. If he cannot supply—WRITE for free circular complete line.

**GENERAL CEMENT MFG. CO., Rockford, Illinois.**

### P. A. is our business!

Your business is to obtain the best in **AMPLIFIERS** Look for our special offer next month.

**FREE CATALOG** contains the greatest values ever offered. Consult us on your P.A. Problems.

**Amplitone Products Company**  
135 LIBERTY ST. NEW YORK, N. Y.

### LES Correspondence Courses in RADIO and ELECTRICAL ENGINEERING

**ELECTRICAL ENGINEERING** covers complete electrical field. Most modern course. So simplified anyone can grasp it quickly. **LOW COST!** Only \$25. Deferred payment plan.

**RADIO ENGINEERING** Ultra-modern course in radio. public address photo-electric work. Trains you to be super-service man, real vacuum tube technician. Diploma given. Exper. Kit—on limited time offer. Tuition only \$25. Deferred payment plan.

Write today for free copies of school catalogs, student magazines, etc. Get started at once. **SEND NOW!**

**LINCOLN ENGINEERING SCHOOL, 931-19 So. 37th St., Lincoln, Nebr.**

# MAKE THIS POCKET-SIZE METER RECTIFIER

(Continued from page 607)

application.

The only alternative then is to use a suitable rectifying device to apply to the d'Arsonval type of meter that is already in the Multitester. The most accurate, rugged and versatile method is to use a tube rectifier (as was previously described in *Radio-Craft* and is now available in a commercial line of testers). However, such a combination would be too large for a pocket-size instrument and would involve a more complicated circuit than the copper-oxide rectifier which is used in this unit.

Fortunately it is not important to have a high degree of accuracy for A.C. measurements in most radio servicing. However, it occasionally is important and every well-outfitted shop should have one instrument whose measurements are dependable at various frequencies and ranges. For general testing, particularly in portable service work, the copper-oxide rectifier is acceptable and is found in most radio service instruments to-day including the most costly ones where its value is questionable.

The completed converter unit is illustrated in Figs. A and B. The 4 A.C. voltage ranges correspond to the D.C. ranges of the Pocket Multitester—5-50-500 and 1,000 V. There has also been added a 1-V. A.C. range for output measurements. Naturally, for this low range the accuracy is less than for other ranges but output readings in service work are practically always relative and absolute values are useless. Thus minimum and maximum readings together with relative increases or decreases as the case might be, are all important.

Some commercial instruments are compensated by condensers in order to minimize the shifting impedance error particularly on the low ranges where the error is proportionately high. This correction is only a makeshift however as it holds good only for one particular frequency and varies considerably at all other frequencies. The writer believes it far more practical and accurate as well as economical to use the simple full-wave rectifying circuit without any compensating device for ordinary measurements but to use a calibration curve where accuracy is desired. A typical calibration curve is shown in Fig. 2.

The simple circuit diagram is shown in Fig. 3 and when constructed presents a rugged, compact unit of neat appearance. It is unusually convenient with respect to application and portability. The 2 output leads are connected to the Multitester, using it as a microammeter. Polarity must be maintained; the black or negative lead is inserted into the jack marked COMMON and the positive, red lead is inserted into the MICROAMP. jack. In constructing a converter unit considerable caution must be observed

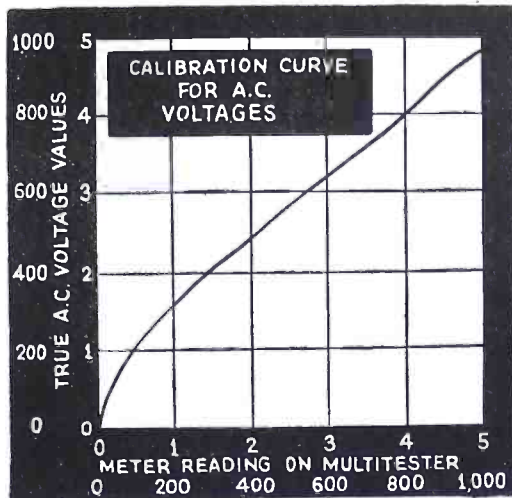

Fig. 2. A typical calibration curve.

in handling the rectifier as carelessness may quite easily damage it permanently. All soldering to the rectifier lugs must be quickly and properly done, as, high temperatures can easily damage the copper-oxide film. The rectifier will not stand any severe physical shock and the initial pressure on the discs must not be changed. This necessitates caution in mounting. The tip-jacks on the converter unit are used for A.C. measurements. One jack is common for all ranges and the various range jacks are designated on the panel.

### LIST OF PARTS

- One Radio City engraved panel;
- One Radio City case;
- Two flexible leads, P1, P2;
- One Dependable resistor, 630 ohms, R1;
- One Dependable resistor, 6,000 ohms, R2;
- One Dependable resistor, 67,000 ohms, R3;
- Two Dependable resistors, 0.7-meg., R4, R5;
- Six tip-jacks, J1 to J6;
- One Dependable full-wave copper-oxide rectifier, FWR.

This article has been prepared from data supplied by courtesy of Radio City Products Co.

## P.S. "HE MADE THE SALE!"

(Continued from page 634)

church board again. After the details of the church's installation had been threshed out, the church board went into a huddle and *unsolicited* wanted to know things and stuff about an installation for the club. So up to the club they trotted with the now precious demonstrator, stopping only to lubricate their vocal cords for another personal appearance before the alluring speaker-intoeer. Their anticipation was as high as a young beauty contest winner, Hollywood bound.

They stopped for lubrication quite often because their vocal cords were in very bad shape—Johnny's too. By the time they left the last lubritorium, the situation, as well as the members of the party, was ripe. When they finally arrived in front of the club house, Mr. Goint was "calling all cars" on the dead mike and occasionally making a noise like a machine-gun. At that, he looked like a tripod.

Finally the thing was worried into the auditorium and set up. And then it started. The rest of the story was assembled from here and there, ear-witnesses, etc., but from the entire composition it was deduced that somehow one of the speakers had been set in the window and community singing resorted to. The first song was "Sweet Adeline" and the last two were "Hinky Dinky Parlevoo" and "Franky and Johnny." With the last named came a police radio car. The system was sold.

And that was the end of the beginning of Johnny's P.A. splurge. His initial investment for the demonstrator was less than \$50 what with some equipment he had on hand. With it he sold the 2 installations, as mumbled above and is well on his way toward selling several more. Furthermore, he has rented out the darn thing on several occasions for 1-night affairs! Is there money in P.A.? Just ask him!

This article has been prepared from data supplied by courtesy of Wholesale Radio Service Co.

Please Say That You Saw It in RADIO-CRAFT

# Train at Home Under FACTORY ENGINEERS for GOOD PAY Spare-Time and Full-Time Jobs in RADIO



## LEARN TO EARN

UP TO \$75 A WEEK

If you're dissatisfied with small pay—and an uncertain future, get my big FREE book, "RADIO'S FUTURE AND YOUR OPPORTUNITY." This book tells how you can learn at home under the supervision of factory engineers to make more money almost at once in Radio—how to make Radio your life's work, or how to earn \$5 to \$20 a week extra in your spare time.

### MORE OPPORTUNITIES THAN EVER BEFORE

Radio is still forging ahead. 1936 beats all other years. Over 6 million new sets sold. Over 30 million dollars paid for service alone. Where only a few hundred men were employed a short time ago, thousands are employed today. And where a hundred jobs paid up to \$75 a week—there are thousands of such jobs today—many paying even more. New full time jobs and spare time jobs are being created all the time.

### "SHOP TRAINING" FOR THE HOME

R-T-I Training is different. It comes to you right out of the factories where Radio sets and other vacuum-tube devices are made. It was planned and prepared and is supervised by radio engineers in these factories—by men appointed for the purpose. R-T-I will train you as the Radio Industry wants you trained.

### TELEVISION, PHOTO ELECTRIC CELLS, PUBLIC ADDRESS SYSTEMS INCLUDED

Radio service work is plentiful but it's only the starting point in R-T-I Training. From there you'll go through the whole field of Radio and Electronics. You will learn about every new development, including Television so you'll be ready when Television breaks.

### 4 WORKING OUTFITS FURNISHED

Start almost at once doing part time radio work. I furnish 4 outfits of apparatus that you build into test equipment with which you can do actual jobs and earn extra money. My training pays its own way, and you get your money back if not satisfied. Age or lack of experience is no handicap.

### FREE BOOK

Find out why R-T-I Trained men get "Quick Results" and "Big Results." Send for "Radio's Future and Your Opportunity" today. It tells about Radio's amazing opportunities. It describes my approved training—what R-T-I students are doing and making. It gives the names of 50 firms who endorse and recommend R-T-I. It's FREE.

Ray D. Smith  
President Radio and Television Institute  
Dept. 224  
2150 Lawrence Ave., Chicago

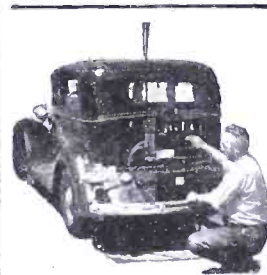

### BIG MONEY IN AUTO AND POLICE RADIO WORK

W. H. Carr, 402 N. 16th St., Kansas City, Kans., R-T-I student has charge of 35 radio equipped Police cars. He gets \$250.00 a month and free auto, gas, oil, etc. He says, "If I had not taken your course I would not be able to hold this job."



### MAKES \$600 IN ONE MONTH

Herbert B. Thomson, Gorman, Texas, started making money with 12 lessons finished. He says, "Because of my R-T-I Training I made \$450 in September and over \$600 in October, 1935. It pays to be R-T-I Trained."

### MAIL COUPON FOR FREE BOOK

RAY D. SMITH, President  
Radio and Television Institute (R-T-I)  
2150 Lawrence Ave., Dept. 224  
Chicago, Ill.

Without obligating me, send FREE Book about spare-time and full-time Radio opportunities and how I can train for them at home.

Name .....

Address .....

City ..... State .....

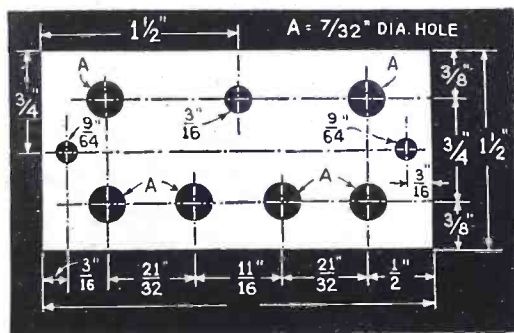

Fig. 3. The rectifier chassis is 3 ins. long.

## PATENTS—TRADE MARKS

All cases submitted given personal attention by members of the firm.

Form "Evidence of Conception" and instructions

"How to Establish Your Rights"—Free

LANCASTER, ALLWINE & ROMMEL

PATENT LAW OFFICES

436 Bowen Bldg. Washington, D. C.

## ELECTRIC EYES

Be the first in your community to install electric eye devices and reap a rich reward. Simple electric eyes for opening doors, announcing people in offices, safety protection across doorways and many other uses can be bought at low cost. \$10.00 cash with order or C.O.D. brings you a marvelous electric eye complete with caesium photo cell. Operates from 110 volts AC or DC. Money back guarantee. If not satisfied return unit to us in good condition within 10 days and money will be refunded. We can supply photo electric equipment for any purpose, sorting machines, grading machines, traffic counters, laundry counters, oil burner safety controls and many other devices. A postcard will bring complete information for any special applications.

ELECTRONIC PRODUCTS COMPANY, St. Charles, Illinois

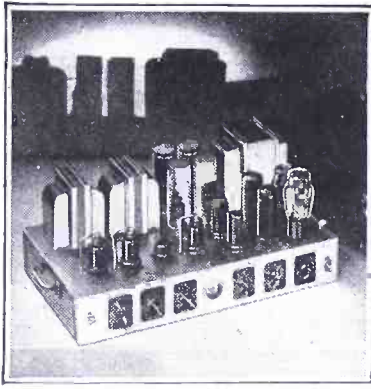

**AN ENTIRELY NEW LINE**

*Designed by A. C. Shaney*

—advanced design High-Fidelity Amplifiers and Complete Sound Systems incorporating all latest audio developments as Automatic Howl Suppression, Volume Level Expansion, Fixed Voltage Beam Power Amplification, Automatic Audio Volume Control, Cathode Ray Indicator, etc., completely described in our Catalog No. 3709.

Write for your **FREE** copy today and ask for full details of our **Five Year Guarantee** and **Attractive Discounts**.

**AMPLIFIER CO. of AMERICA**  
37 West 20th Street New York, N. Y.

**POWERTONE**

Model 801—Pocket Volt-Ohmmeter

A sensitive, compact and accurate volt-ohmmeter that will be the busiest instrument in your "lab," or out on jobs.

DC voltage readings -0.5-50-500 and 1000. Resistance readings from 1/2 to 500 and 200 to 500,000 ohms. Will read from 0 to 1 Ma. Low resistance range direct reading.

Meter has 1000 ohm per volt sensitivity. Battery is self contained. Panel is clearly lettered. Compensator provided for zero adjustment.

Measures only 5"x3 1/4"x2 1/2". Your price complete with battery



**\$5.75**

Send for complete literature on a variety of test instruments  
Send 10c for information Short-Wave and P.A. Manual

**POWERTONE ELECTRIC CORP.**  
179 Greenwich Street New York City

Distributor  
**TRY-MO RADIO CO., Inc.**  
85 Cortlandt St. New York City

**2 BAND SUPER COIL KIT**

Tunes from 6 to 15 Megacycles  
1700 to 550 KC. Tunes with 456 I.F.

KIT CONSISTS OF:

- 1 Shielded antenna coil
- 1 Shielded Oscillator coil
- 1 Band Switch

**99¢**

TAKE ADVANTAGE OF THIS GREAT VALUE  
NO C.O.D. SHIPMENTS Shipping Wt. 1 lb.

**ARROW SALES COMPANY**  
631 Washington Blvd., Chicago, Illinois

**NEW GUIDE NOW READY!**

Most complete volume control facts ever assembled in one book. Free with top (showing spec. number) of one Electrad volume control carton.

Write Dept. RC-4

175 Varick St., New York, N.Y.  
**ELECTRAD**

**DYNAMIKE!**

A real velocity, high quality microphone for speech or music. Equals instruments selling for three times the price. Response substantially flat from 40 to 10,000 C. P. S. Cavity resonance eliminated through special design. High impedance. Output, 69 D. B. Equipped with six feet of shielded cable. Send \$9.95 (plus postage) today or request free circular.

**\$9.95** Plus Postage

ELECTRO-DYNE MFG. CO., Benton Harbor, Mich.

**MORSE**  
ELECTRICAL SPECIALTIES CO.

**PRECISION WORK**  
ON ALL TYPES OF ELECTRICAL EQUIPMENT  
Repairing • Calibrating • Testing • Servicing  
SPECIAL PROBLEMS SOLVED  
**MORSE ELECTRICAL SPECIALTIES CO**  
127 N. DEARBORN STREET, CHICAGO, ILL.

**THE MARCH OF TUBES**

(Continued from page 587)

lower value of grid resistance, and thus reduces the gain of the preceding stage.

When used in push-pull the 6AC6G will produce 9.5 W. of audio power at a total harmonic distortion of 10 per cent. When necessary to minimize plate current, a bias of 50 ohms which reduces the total plate current to 70 ma. at no-signal, may be used.

**6H5 Tuning Indicator.** The 6H5 differs from the 6G5 and 6E5 tuning indicator tubes in the addition of a current-limiting grid around that portion of the cathode which furnishes emission for the target current, according to data from National Union Tube Co. This additional grid is connected internally to the cathode and acts solely to prevent the target current from rising above a fixed value.

The A.V.C. voltage required to change the shadow from 90 deg. to 0 deg. is 22 V. Where the A.V.C. voltage in the receiver reaches higher values than 22 V., a voltage dividing system is necessary to limit the bias applied to the 6H5.

**6T7G Duo-Diode High-Mu Triode.** This is a new tube having a filament current of only 0.15-A. The tube has characteristics very similar to the 6Q7G. The triode section operated with a plate voltage of 250 and a plate load resistor of 0.1- to 0.25- meg. should have a negative bias of 2.5 V. on the grid.

**6V6G Beam-Power Amplifier.** The 6V6G is a beam-power amplifier similar in design features to the 6L6G, but having a high power sensitivity, high power output, and low percentage of third and higher order harmonics.

The 6V6G should prove very desirable where heater and plate current must be maintained at a minimum. The heater current of 0.45-A. is rather low for a power tube having the power capabilities of the type 6V6G.

**6V6G Characteristics**  
Class AB1 amplifier (push-pull)  
Values are for 2 tubes

Heater voltage	6.3	6.3 V.
Plate voltage	250	300° V.
Screen-grid voltage	250	300° V.
Total plate and screen-grid dissipation (per tube)	...	12.5 W. max.
Control-grid voltage*	-15	-20 V.
Peak input signal (grid to grid)	21.2	28.2 V. approx.
Plate current (zero signal)	70	78 ma.
Plate current (max. signal)	79	90 ma.
Screen-grid current (zero signal)	5	5 ma.
Screen-grid current (max. signal)	12	13.5 ma.
Load Resistance (plate to plate)	10,000	8,000 ohms
Total harmonic distortion	4	4 per cent
3rd harmonic	3.5	3.5 per cent
Power output	8.5	13.5 W.

\*Maximum. "1" used in conjunction with the terms class A and class AB indicates that no grid current flows during any part of the input cycle.

\*Transformer and impedance coupling devices are recommended and the resistance introduced in the control-grid circuit should be kept as low as possible. For fixed bias this resistance should not exceed 50,000 ohms. The maximum control-grid resistance when self-bias is employed may be 0.5-meg.

\*\*The self-bias resistor should be shunted with a suitable filter network to reduce degeneration.

**25A7G Pentode-Rectifier Tube.** This tube combines the functions of power amplification and rectification within one envelope. A pentode power-output section similar to the type 43 and a half-wave rectifier—somewhat similar to the 12Z3—comprise the internal elements.

Designed for small A.C.-D.C. receivers where space is at a premium, this combination tube will produce a power output of 0.77-W. with about 9 per cent distortion and will supply a voltage for the speaker field and the plate supply at a maximum current of 75 ma.

**25A7G Characteristics**

Heater voltage	25.0 V.
Heater current	0.3-A.
Operating Conditions	Pentode Section
Plate	100 V.
Screen-grid (grid No. 2)	100 V.
Control-grid (grid No. 1)	-15 V.
(Grid No. 3 tied to cathode within tube)	
Plate current	20.5 ma.

Please Say That You Saw It in RADIO-CRAFT

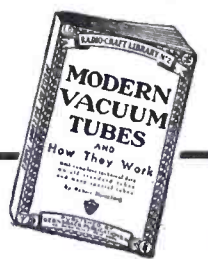

*Learn More About*  
**RADIO and A B C of AIR CONDITIONING**

**THE RADIO-CRAFT LIBRARY SERIES**—a most complete and authentic set of volumes—treats individually, important divisions of radio. Each book has been designed to give you the opportunity to learn one or more branches of radio. The authors of the books are well-known to everyone. Each is an expert radio man; an authority on the subject—each is thoroughly familiar with the field which he represents.

*All Books Uniform*

The volumes in the RADIO-CRAFT LIBRARY SERIES are all uniform, 6 x 9 inches. Each book contains on an average of 50 to 120 illustrations. The books are printed on an excellent grade of paper which makes the type easy reading.

- No. 1  
**RADIO SET ANALYZERS**  
By L. VAN DER MEL
  - No. 2  
**MODERN VACUUM TUBES**  
By ROBERT HERTZBERG
  - No. 3  
**THE SUPERHERODYNE BOOK**  
C. J. FITCH
  - No. 4  
**MODERN RADIO HOOK-UPS**  
By R. D. WASHBURNE
  - No. 5  
**HOW TO BECOME A RADIO SERVICE MAN**  
By LOUIS MARTIN
  - No. 6  
**BRINGING ELECTRIC SETS UP TO DATE**  
By CLIFFORD E. DENTON
  - No. 7  
**RADIO KINKS AND WRINKLES**  
By C. W. PALMER
  - No. 8  
**RADIO QUESTIONS AND ANSWERS**  
By R. D. WASHBURNE
  - No. 9  
**AUTOMOBILE RADIO AND SERVICING**  
By LOUIS MARTIN
  - No. 10  
**HOME RECORDING AND ALL ABOUT IT**  
By GEORGE J. SALIBA
  - No. 11  
**POINT-TO-POINT RESISTANCE MEASUREMENTS**  
By CLIFFORD E. DENTON
  - No. 12  
**PUBLIC ADDRESS INSTALLATION AND SERVICE**  
By J. T. BERNSELY
  - No. 13  
**A B'C OF AIR CONDITIONING**  
By PAUL D. HARRIGAN
  - No. 14  
**POCKET RADIO GUIDE**  
By NAT LESSEM
- BIG DISCOUNT OFFERED**  
When Five (5) Books or More Are Ordered, Deduct 20%

**RADCRAFT PUBLICATIONS, INC.**  
99 Hudson Street, New York, N. Y.

RADCRAFT PUBLICATIONS, INC. RC-437  
99 Hudson Street, New York, N. Y.

I have circled below the numbers of books in the RADIO-CRAFT LIBRARY SERIES which you are to send me, and have deducted 20% for ordering five (5) books or more. I have included my remittance in full, at the price of 50c each, when less than five books are ordered.

The amount of my remittance is..... (stamps, checks or money orders accepted). Circle numbers wanted:

1 2 3 4 5 6 7 8 9 10 11 12 13 14

Name .....

Address .....

City ..... State .....

All books are sent postage prepaid



**"Have You Seen the 3 NEW SPRAGUE UNIVERSAL REPLACEMENTS?"**

**SPRAGUE**  
*The Standard of Condenser Quality*

"With these handy new Sprague Universal Replacement Condensers you are ready for quick, accurate service on hundreds of different radios:

**TYPE BT-100**—(Rectangular Type—8 leads) has three 8 mfd. sections (8-8-8, 200 volts) also two 5 mfd. sections (5-5, 25 volts). Gives you many needed combinations such as 8-16; 12-16; 10-16; 5-20, etc., etc. 5 mfd. sections may be used as single 10 mfd. List Price \$2.50, Net \$1.50.

**TYPE ST-10**—Same as BT-100 except in rectangular cardboard casing with mounting lugs. List Price \$2.50, Net \$1.50.

**TYPE BT-1**—Three sections (5-10-25 mfd. all 150 volts) six leads give you any needed combination of these capacities. List Price \$1.95, Net \$1.17.

See them at your jobbers... Write for Catalog.

**SPRAGUE PRODUCTS CO., North Adams, Mass.**

Screen-grid current	4 ma.
Amplification factor	90
Plate resistance	50,000 ohms
Mutual conductance	1,800 mmhos
Load resistance	4,500 ohms
Total harmonic distortion	9 per cent
Power output	770 milliwatts

Rectifier Section  
A.C. plate voltage (r.m.s.) 125 max. V.  
D.C. output current 75 max. ma.

**25L6 Metal Beam Power Amplifier.** The design of the 25L6 is similar to that of the 6L6 with the difference that the 25L6 is intended for use in the output stage of transformerless receivers operating from a 115 V. power line, either A.C. or D.C. According to the data received from RCA, this tube has high sensitivity, high efficiency and high power output. With 110 V. on the plate and screen-grid, the 25L6 is capable of giving an output of 2.2 W. with a maximum signal input of only 5.3 V. r.m.s.

**25L6 Characteristics**

Heater voltage	25.0 V.
Plate voltage	110 max. V.
Screen-grid voltage	110 max. V.
Control-grid voltage	-8 V.
Zero-signal plate cur.	45 ma.
Max.-signal plate cur.	48 ma.
Zero-signal screen-grid cur.	3.5 ma.
Max.-signal screen-grid cur.	10.5 ma.
Signal input voltage	5.65 V. r.m.s.
Plate resist. (Approx.)	10,000 ohms
Transconductance	8,000 mmhos
Load resistance	2,000 ohms
Distortion: Total harmonic	11.5 per cent
Power output	2.2 W.

**25Z5 Improved Rectifier.** One radio tube company\* has just released an improved type of 25Z5 rectifier tube which reduces to a minimum the possibility of flash-overs, open cathode tabs, slow heating, shorts and filament burn-outs. These improvements should remove some of the headaches which dealers and Service Men have encountered with this type of tube.

**920 Twin Phototube.** This new tube announced by the RCA Manufacturing Co. is a gaseous-type photoelectric cell containing 2 separate photocells in one glass envelope. It is designed primarily for use with double-sound-track film in a system of sound reproduction having a high signal-to-noise ratio. In this system the light on one unit of the 920 varies from zero to maximum in accordance with the positive half-cycles of the signal recorded on one sound track. The light on the other unit varies from zero to maximum with the negative half-cycles recorded on the other sound track. The outputs of the 2 phototube elements are combined to give a full-wave signal current.

**1603 Triple-Grid Detector-Amplifier.** This tube is designed for preamplifier equipment which is critical as to noise and microphonics. As a pentode, the 1603 is capable of delivering a large A.F. output voltage with relatively low input voltage. As a triode (that is, with the grids tied together) the tube has a high mutual conductance together with a comparatively high amplification factor. The tube is constructed with an internal shield connected to the cathode.

**1603 Characteristics**

Heater voltage (A.C. or D.C.)	6.3 V.
Heater current	0.3 -A.
As class A amplifier pentode	
Plate voltage	100 250 max. V.
Screen-grid voltage (grid No. 2)	100 100 max. V.
D.C. grid voltage (grid No. 1)**	-3 -3
Suppressor (grid No. 3)	tied to cathode at socket
Amplification factor	1,185 greater than 1,500
Plate resistance	1.0 Greater than 1.5 meg.
Mutual conductance	1,185 1,225 mmhos
Plate current	2 2 ma.
Screen-grid current	0.5- 0.5- ma.
As class A amplifier triode*	
Plate voltage	180 250 max. V.
D.C. grid voltage	-5.3 -8 V.
Amplification factor (approx.)	20 20
Plate resistance	11,000 10,500 ohms
Mutual conductance	1,800 1,900 mmhos
Plate current	5.3 6.5 ma.

\*\*D.C. grid voltage is -7 V. for cathode current cutoff.

This concludes the tube descriptions for this month. Because of the relatively large number of tubes released the descriptions are necessarily short in some cases, and therefore curves, available from the manufacturers, have been omitted.

\*Names of manufacturers will be sent upon receipt of a stamped and self-addressed envelope.



**"SURE!... and do you know Sprague has the biggest list of EXACT DUPLICATE REPLACEMENTS?"**

**CONDENSERS**  
*USE SPRAGUES... and Note the Difference*

"If you were to visit us here in North Adams you'd be amazed at the thousands of condenser types we are making regularly. As a matter of fact, there is hardly a radio receiver manufacturer of any size who isn't using Sprague Condensers today. That's why our list of exact duplicate condenser replacements is so amazingly large—why you can call on us for any condenser you'll ever need in radio amateur or service replacement work. Round, square, dry or wet, special shapes, special mountings, unusual types—no matter what your requirements, we can supply 'em. Try Sprague First!"

Sincerely, *Harry Kalkreuth*  
Sales Manager,

**SPRAGUE PRODUCTS CO., North Adams, Mass.**



**Vest Pocket Adding Machine**

Sturdy Steel Construction. Lifetime Pocket Companion. Adds, Subtracts, Multiplies, Divides. Capacity, 999,999.99. A real machine—guaranteed 5 years. Send name and address. We ship immediately. On delivery, pay postman \$2.50 (plus few cents postage). (Foreign countries send cash.)

**Free \$2.50 Trial**  
Send no money  
Your money back after 10 days trial if not satisfied. Thousands of satisfied users. Send for Special Offer to agents.

**TAVELLA SALES CO., 21 West Broadway, New York, N. Y.**

**FACTORY TO YOU**  
**NEW REMINGTON NOISELESS PORTABLE!**



**10¢ A DAY**

**Famous Remington Noiseless Portable that speaks in a whisper, only 10c a day, direct from factory. Standard keyboard. Automatic ribbon reverse. Variable line spacer and all the conveniences of the finest portable ever built. PLUS the NOISELESS feature. Act now. Send coupon TODAY for details.**

**You don't RISK a Penny**  
We send you Remington Noiseless Portable for 10 days' free trial. If not satisfied, send it back. We pay all shipping charges.

**FREE Typing Course and Carrying Case**  
You will receive FREE a complete simplified home course in Touch Typing. Also FREE, a handsome, sturdy carrying case. No obligation. Mail coupon for full details—NOW

Remington Rand Inc., Dept. 189-4  
815 Fourth Ave., New York, N. Y.

Tell me, without obligation, how to get a new Remington Noiseless Portable, plus Free Typing Course and Carrying Case, for 10c a day. Send Catalogue.

Name.....  
Address.....  
City..... State.....

**NOT A BOAST.... BUT A FACT!**

The Kenyon oscilloscope power transformer has been the accepted choice of all the leading radio magazines when featuring oscilloscopes utilizing the new 913 miniature cathode ray tube.

Don't accept makeshift substitutes. ALWAYS SPECIFY KENYON POWER TRANSFORMER TYPE T-207.

**Your Net Price \$2.40**

For Particulars of various oscilloscopes using this power transformer to full advantage ask your local dealer for the second issue of KENYON ENGINEERING NEWS.

**KENYON TRANSFORMER CO., Inc.**

**846 Barry St., New York, N. Y.**

Export Dept. 25 Warren St., New York, N. Y. Cable Address SIMONTRICE-NEW YORK

Please Say That You Saw It in RADIO-CRAFT

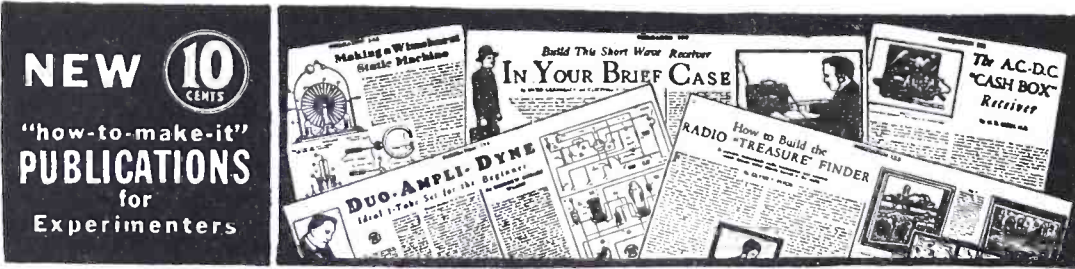

**NEW 10 CENTS**  
**"how-to-make-it" PUBLICATIONS**  
 for Experimenters

WE list below a large number of radio, short-wave, and mechanical "how-to-make-it" designs. Each is a special publication originated by masters in their respective fields. For the first time, at the low price of TEN CENTS you are now enabled to buy a complete design with photographic reproductions, complete mechanical layout, and full description to make it possible for anyone to build the project in question. The name of "Radio Publications" has become a household word because this company has for many years specialized in radio and other literature of special interest to the experimenter. PLEASE ORDER EACH PROJECT BY ITS PUBLICATION NUMBER, and use the special coupon below. We accept money-orders, cash, checks or new U. S. stamps. (No foreign stamps or currency can be accepted.) If you send cash or stamps, be sure to register your letter to safeguard against loss. Money refunded if you are not satisfied.

**ANY TWELVE PUBLICATIONS FOR ONE DOLLAR**

**Partial List of New 10 Cent Publications**

**SHORT-WAVE RECEIVER PUBLICATIONS**

- HOW TO MAKE THE 2 TO 5 METER TWO-TUBE LOUD-SPEAKER SET. This receiver may be used with batteries or with an A.C. power pack. Packs a big wallop. No. 107
- HOW TO BUILD THE CIGAR-BOX 1-TUBE "CATCH ALL" RECEIVER. An effective short-wave battery set which fits into a small cigar-box, insuring high portability yet great efficiency. No. 111
- HOW TO BUILD THE PORTABLE MINIDYNE SHORT-WAVE BATTERY SET. Uses no aerial, no ground. The total weight is 3 1/4 lbs. and measures 5x5x6 inches. Self-contained batteries, tube, condensers, and loop. Highly sensitive circuit. No. 114
- HOW TO BUILD THE HAM-BAND "PEE-WEE" 2-TUBER. A dandy receiver with high efficiency and bandspread tuning. Works a loudspeaker, yet the entire receiver is no larger than your hand. Works with either batteries or an A.C. power pack. No. 115
- HOW TO BUILD THE DUO-AMPLIDYNE. The ideal 1-tube set for the beginner. One of the finest 1-tube sets; it really gives 2-tube performance. Made for battery operation. With only ten-foot antenna brings in the good European stations. No. 116

**RADIO BROADCAST RECEIVER AND SPECIAL RADIO PUBLICATIONS**

- HOW TO BUILD A SUPER-SENSITIVE ALL-WAVE CRYSTAL SET. Just the thing for beginners who wish to have an easy-to-operate crystal set on all-waves and which will separate all the stations. Can be made for less than \$2.00. Uses no tubes or batteries. No. 121
- HOW TO BUILD THE 2-TUBE "PENTODE PORTABLE" BROADCAST SET—the lightest, smallest set giving loud-speaker volume on batteries. Weighs less than 12 pounds. Built in a small, portable case. No. 122
- HOW TO BUILD THE RADIO "TREASURE" FINDER. This is a really sensitive and practical "Treasure" finder. Simple to build and guaranteed to work. Uses 4 tubes. Can be built for less than \$15.00. No. 123
- HOW TO BUILD THE GERNSBACK ONE-TUBE PENTODE LOUDSPEAKER SET. This is the best one-tube loud-speaker set ever constructed. It works on batteries, and is for broadcast reception. Extremely sensitive. No. 124
- HOW TO BUILD THE WORLD'S SMALLEST ONE TUBE BATTERY RADIO. So small that it is actually built in a cigarette case. The wonder set of the last New York radio show. No. 125
- HOW TO BUILD A 6-TUBE BATTERY ALL-WAVE "FARM PORTABLE" SET, ranging from 12 to 2,100 meters. A real portable that pulls in the stations. No. 126
- HOW TO MAKE AN A.C.-D.C. ONE-TUBE "DEAF AID." An excellent aid for the hard-of-hearing and deaf, for theatres, churches, and the home. A godsend for all afflicted persons. Can be built for a few dollars. No. 127
- HOW TO BUILD A PIANOTRON. For less than two dollars, plus a few junk parts which you have, you can now make a beautiful musical instrument. Operated by three radio tubes. It has an actual keyboard, and you can play tunes. Works on "A" and "B" batteries. A great novelty due to the unusual music which issues from the loud-speaker. No. 128
- HOW TO BUILD THE ONE-DOLLAR RADIO. Impossible though it sounds, for one dollar you can build a radio set which includes a radio tube and a pair of headphones and batteries. You make everything yourself outside of the three last mentioned items, from wood and spare metal parts. No. 129

**MECHANICAL PROJECTS PUBLICATIONS**

- HOW TO BUILD A PEE-WEE AUTOMOBILE. An ultra-small automobile that can be built for less than 10 dollars. Will carry two 17-year-old boys. Runs 35 miles per hour and 100 to 125 miles on one gallon of gas. No. 132
- HOW TO MAKE A BAND SAW FROM OLD AUTO PARTS. Made from old Ford and Chevrolet parts. Capable of performing delicate and satisfactory work. Uses 25-gauge 10 and 12-inch band saws. Assembly is easy for each part fills its allotted place perfectly. No. 135
- HOW TO BUILD A REAL LATHE FOR \$5.00. Requires a few hand tools, about \$5.00 worth of raw material and patience to build. The lathe is capable of drilling, milling, trimming, boring and thread cutting. No. 136
- HOW TO BUILD A SIMPLE PORTABLE REFRIGERATOR. A real refrigerator. Does not use ice. The cooling unit operates from an alcohol flame, oil burner or open fire. Easy and inexpensive to build. Excellent for boats, camps, picnics, etc. No. 138
- HOW TO BUILD LARGE TESLA AND OUDIN COILS GIVING 18-INCH SPARKS. Interesting high-frequency apparatus with which many high-frequency and x-ray experiments can be performed. Capable of producing 15,000 volts. No. 141
- HOW TO MAKE AN ARC WELDER. A real arc welder capable of doing commercial jobs satisfactorily. Uses a heavy duty transformer which operates from the 110-volt A.C. main. The output of the machine ranges from 15 to 100 amperes. No. 142
- HOW TO USE AN A.C. ARC WELDER. Companion publication to the one listed directly before. Very informative; especially to the garage man or mechanic who has had little or no experience with an arc welder. Contains many important diagrams and photographs of actual work done with an arc welder. No. 143
- HOW TO MAKE YOUR OWN MICROSCOPE. A microscope which the home mechanic can easily build in his shop. The lenses are obtained from the finders of a camera. Although simple and easy to build, it is a thoroughly practical and efficient instrument. No. 144
- HOW TO MAKE A WIMSHURST ELECTROSTATIC MACHINE. An easily constructed generator of static electricity capable of discharging a fat three-inch spark. Used in schools where electricity is taught. Can be built for less than \$2.00. No. 145
- HOW TO MAKE A POWER DRILL PRESS FROM SCRAP PARTS. An excellent practical drill press that will make work easier for the mechanic. About \$2.00 worth of raw material and scrap iron are the only requirements. No. 146
- HOW TO MAKE AND EXPERIMENT WITH AN ELECTROPHORUS. With this device numerous interesting experiments with static electricity can be performed. Many of these experiments are thoroughly explained and illustrated. No. 148

**RADIO PUBLICATIONS 99A HUDSON STREET NEW YORK, N. Y.**

**RADIO PUBLICATIONS, 99A Hudson Street, New York, N. Y. RC-437**

I enclose \$..... for the publications listed by number, at right, at 10c a copy (ONE DOLLAR FOR TWELVE PUBLICATIONS.) These publications are to be sent to me postpaid. I have placed a circle around each number which I want.  
 Send me also your list of 27 other 10c publications.

	107	111	114	115	116
	121	122	123	124	125
	126	127	128	129	132
Name .....	135	136	138	141	142
Address .....	143	144	145	146	148
City .....					
State .....					

**PHOTOTUBES AND PHOTOCELLS—WHEN TO USE THEM**

(Continued from page 592)

out into the open; while the surface of a dry disk photocell may be likened to the skin complete with epidermis.

As a matter of fact, a phototube will develop an electromotive force on an open circuit when exposed to light, and will also deliver a short-circuit current, both without aid of an external battery. On the other hand, a photocell may be used with an external battery to exhibit the characteristics of a phototube shunted by a non-ohmic resistance.

**LIGHT VALVE AND LIGHT GENERATOR**

The phototube may be regarded as a light-actuated current valve which is opened by an amount directly proportional to the incident light flux. The current, small as it may be, can be driven full-strength through any resistance, the maximum value of which is limited only by the available e.m.f. in the external circuit.

The photocell may be regarded as a light-actuated generator, the output of which is a direct function of the intensity of the incident light. If a photocell is connected to a low-resistance device, and its own internal series resistance is low, the current delivered will be linearly proportional to the light intensity.

**CURRENT SENSITIVITY**

The useful characteristics of the photocell are its low-resistance current sensitivity expressed in microamperes per lumen, or better, microamperes per foot-candle per sq. in., and especially its maximum power output expressed in microwatts per foot-candle per square inch. Current sensitivity ranges from about 100 to 500 microamperes per lumen or about 1 to 4 microamperes per foot-candle per sq. in. Maximum power output ranges up to 1 microwatt per foot-candle per sq. in. The logical application of the photocell is first of all to light-metering, in which the cell is associated with a calibrated meter in a portable unit or in which the cell serves as a light-intensity indicator in an associated circuit, and, secondarily, to certain control devices in which it has been proved feasible to employ a delicate d'Arsonval relay as the first of a sequence of relays.

**"CURRENT-COLOR" RESPONSE**

It does not seem necessary here to reproduce all of the characteristic curves for typical phototubes and photocells, as our present interest is more restricted to their use in measuring light in various parts of the spectrum. Hence we shall limit ourselves to an examination of typical spectral response or "current-color" curves. In order that we may follow some logical principle of division in our procedure, let us begin with the long waves of the infrared and then proceed toward the regions of shorter wavelength.

There is no photoelectric device which has any appreciable response for wavelengths longer than 2 microns. In practice, one need not expect any useful response beyond 1.2 micron in cesium-oxide phototubes.

In Fig. 1A are given spectral curves for some experimental cesium-oxide phototubes made by Teves. It appears that these curves illustrate the greatest infrared response that has been reported to date for phototubes. In the region from 0.7- to 1.4 micron such tubes can be very conveniently used to measure or to be actuated by infrared light. A cesium-oxide tube, together with a visibly opaque, infrared transmitting filter such as Corning Glass No. 254 or Jena Glass No. RC-9 or Wratten No. 87, comprises a unit sensitive only to the region just defined. As tungsten lamps radiate maximum energy in the same region, an efficient system for an invisible burglar alarm is readily suggested.

Both selenium and copper-oxide photocells can be made to have near infrared response, although generally the selenium cell is more red-sensitive as seen in Fig. 1D where curves for typical copper-oxide and selenium cells are shown together with a shaded curve illustrating the range of sensibilities for 125 human eyes.

**VISIBLE SPECTRUM CONSIDERED**

In the visible spectrum it becomes convenient to evaluate light intensities in terms of visibility. Hence it is highly desirable to employ a light-sensitive device, the spectral response of which resembles as nearly as possible that of the eye. Photocells meet this specification much

**DO NOT FAIL** to read the important announcement which appears on page 626 of this issue. It is important news to everyone who is in the radio business.

**PATENTS and TRADE MARKS**  
 Protect your most valuable assets. Expert service. Prompt attention. Write  
**LESTER L. SARGENT**  
 Registered Patent Attorney  
 1115 K St., N. W., Washington, D. C.

**BUILD IT YOURSELF**  
 You can build this Trailer with ordinary tools easily from our step-by-step constructional sheets and large sized blueprints. Finest designed Trailer in existence, sleeps 4. Toilet, Shower, Electric Light, etc. Save 75% of the cost by building it yourself. Send 25c for plans and illustrations and details.  
**THE PLAN SHOP, 910 Palmolive Bldg. Chicago, Ill.**

Please Say That You Saw It in RADIO-CRAFT



# IN 1937 USE

## Imprinted THREE-COLORED ADVERTISING PENCILS AS BUSINESS CARDS

In 1937 hand your customers and prospects a modern, impressive business card—a white pencil with your name, type of business, address, city and telephone number clearly printed in black with a decorative red flash border.

Imprinted advertising pencils (instead of old-fashioned paper business cards) are becoming more and more popular. Pencils are useful, and very effective business boosters. They bring prospects back, and help make sales. As one consistent user of advertising pencils says, "Every time an imprinted pencil is used by a prospect, his or her thoughts turn to the advertiser. Sooner or later a sale is made."

Imprinted advertising pencils are used by thousands of firms. THEY ARE INEXPENSIVE AND EFFECTIVE SILENT SALESMEN.

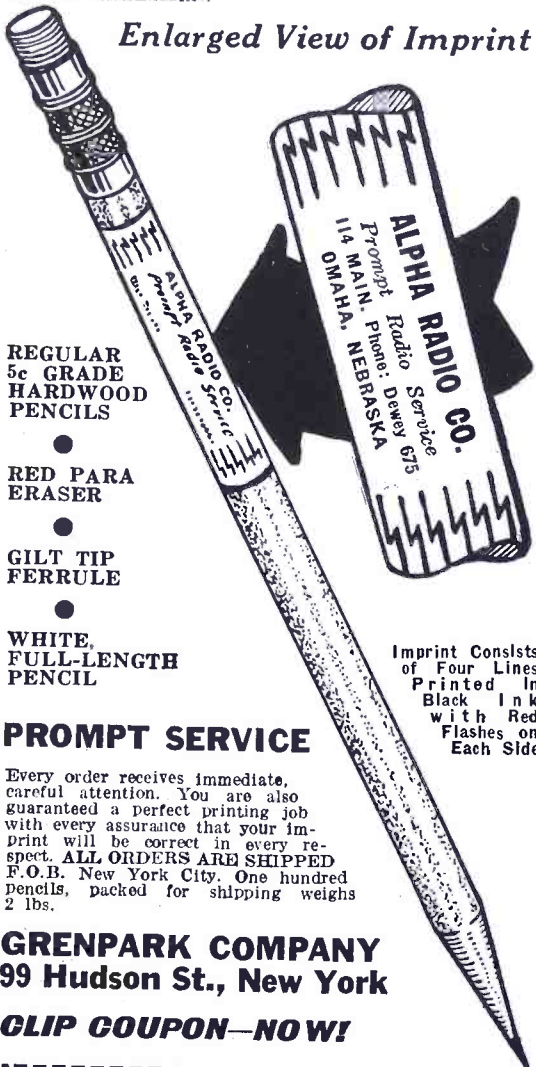

Enlarged View of Imprint

REGULAR  
5c GRADE  
HARDWOOD  
PENCILS

RED PARA  
ERASER

GILT TIP  
FERRULE

WHITE,  
FULL-LENGTH  
PENCIL

### PROMPT SERVICE

Every order receives immediate, careful attention. You are also guaranteed a perfect printing job with every assurance that your imprint will be correct in every respect. ALL ORDERS ARE SHIPPED F.O.B. New York City. One hundred pencils, packed for shipping weighs 2 lbs.

**GRENPARK COMPANY**  
99 Hudson St., New York

**CLIP COUPON—NOW!**

GRENPARK COMPANY RC-437  
99 Hudson St., New York, N. Y.

Gentlemen: Enclosed you will find my remittance of \$..... for which you are to imprint the number of Pencils checked below.

100 for \$4.00

200 for \$6.50  300 for \$8.25  400 for \$9.50  
 500 for \$10.25  750 for \$13.50  1,000 for \$17.00

The copy is to be imprinted as follows:

(Print carefully name of company or individual)

(Slogan of six words)

(Address)

(Telephone Number)

(Town or City)

(State)

Send remittance in form of check or money order. Register letter if you send cash or currency. (No C.O.D. Orders Accepted).

more nearly than phototubes, as a matter of fact copper-oxide cells can be made with natural response amazingly close to the average eye curve. In general, copper-oxide cells tend to be somewhat shy in red response, while selenium cells have excess sensitivity in both red and violet. However, by use of a suitable filter, at the expense of rated sensitivity, the selenium cell can always be made equivalent to the eye.

In devices such as color matchers or color analyzers in which it is necessary to obtain comparable responses in all parts of the visible spectrum, one should have a light-sensitive unit at least as responsive to violet as it is to other colors. In fact, since the tungsten lamps, which serve as sources, are notoriously weak in violet radiation compared to red, it is highly desirable to use a light-sensitive unit more sensitive to violet and blue than to red. In Fig. 1C it may be seen that the normal cesium-oxide tube is relatively weak for blue light. Fortunately it is possible to modify the manufacturing schedule so as to obtain a "blue-sensitive" tube which is almost ideal for the application. Superfluous infrared response can be conveniently removed by means of an infrared absorbing filter such as Corning Aklo Glass.

It is probably a general impression that cesium-oxide cathodes have a sharp maximum of response in the near ultra-violet. This peak, however, is only apparent as is shown in Fig. 1C. The sharp cut-off on the short wavelength side is caused by the absorption of the glass envelope. Putting the cathode in a Corex D envelope, which is more transparent to ultra-violet, the curve is seen to shift. Such a tube is doubtless the most sensitive device known for measuring ultra-violet light between 2,000 and 3,000 Angstroms.

### "ULTRA-VIOLET" TUBES

Doubtless a more elegant method for measuring isolated regions in the ultra-violet is provided through the use of "photox" or special ultra-violet phototubes developed by Rentschler, Henry and Smith\* of the company with which the writer is connected. These tubes consist of pure sputtered films of various metals enclosed in envelopes of Corex glass or quartz. Although their current sensitivity is relatively low, they have the distinct advantage of having their total response confined to quite narrow spectral regions of the ultra-violet, being entirely insensitive to any other light. The long-wave limit is defined by the threshold frequency of the particular metal involved while the short-wave limit is fixed by the absorption characteristic of the envelope.

Typical spectral curves for such tubes are given in Fig. 1E. It is apparent that practically any desired region may be isolated by suitable choice of metal and envelope. It is feasible to amplify the current from these tubes, many suitable circuits having been published.

(This concludes the discussion of light-sensitive cells, and the respective colors to which the several types of cells are particularly responsive. It is hoped that the data contained in this article will be of assistance to experimenters in every field of electronics who are looking to find the type of light-sensitive set-up best adapted to an individual need. The material in this article is an abstract from a paper presented in Cincinnati, last year, before the Electrochemical Society.—Editor)

The captions for the graphs in Fig. 1 are briefed as follows:

Fig. 1A—Spectral curves for several experimental cesium-oxide phototubes showing extent of excursion into the infrared. (After Teves)

Fig. 1B—Spectral curves for cesium-oxide tube in lime glass and Corex D glass envelopes. The dotted curve illustrates the differential response as a method of measuring intensity in an isolated spectral region.

Fig. 1C—Spectral curves for "red-sensitive" and "blue-sensitive" cesium-oxide phototubes. Additional curves show influence of envelope on ultra-violet response of the "red-sensitive" type.

Fig. 1D—Spectral curves (typical) for selenium and copper-oxide cells as compared to the range of sensibility curves for the human eye.

Fig. 1E—Spectral curves showing change in threshold of frequency in the ultra-violet for various metallic cathodes. (After Rentschler, Henry, and Smith, by courtesy of R.S.I.)

Our Information Bureau will gladly supply manufacturers' names and addresses of any items mentioned in RADIO-CRAFT. Please enclose a stamped return envelope.

Please Say That You Saw It in RADIO-CRAFT

# NOKOIL

The name that insures Satisfaction

The original new type Permanent Magnet Speaker. Eliminate trouble by insisting on NOKOIL Reproducers.

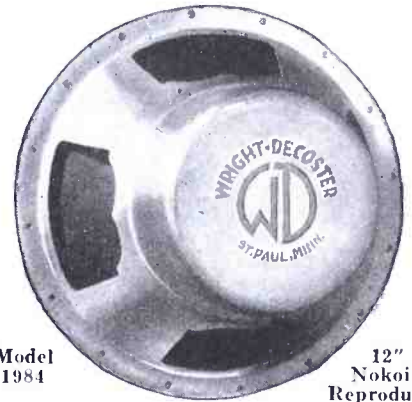

Model  
1984

12"  
Nokoil  
Reproducer

- Power handling capacity 15 watts
- Brass Magnetic housing also covers transformer
- Solid Center spider protects air gap

Thoroughly adaptable for indoor or outdoor use. We know this reproducer will please you.

List Price only \$19.84

Write for catalog showing World's most complete line of speakers.

Ask for the name of our nearest distributor. Wright-DeCoster distributors are always anxious to cooperate.

## WRIGHT-DECOSTER, Inc.

2251 University Ave., St. Paul, Minnesota  
Export Dept.—M. Simons & Son Co., New York.  
Cable Address: "Simontrico."  
Canadian Office: Associated Sales Co., Guelph, Ont.

# "I Don't Worry"

About Radio Supply Troubles



Neither Does  
Our Radio Man...

## HE BUYS AT RADOLEK!

He saves time! He saves money! He doesn't have to "split" his orders. He's happy and making money... because he uses Radolek's Radio Supply Service... the finest, fastest, most complete source of Radio Parts in the world. Radolek SPECIALIZES in giving the radio-man what he wants, when he wants it, and at the right prices. This new 1937 Radolek Radio Profit Guide is just off the press



Over 12,000 values... Hundreds of new items. Merchandise you've never seen before. Repair Parts, Radio Sets, Amplifiers, Test Instruments, Tubes, Tools, Books, "everything in Radio and Public Address." You need this complete "guide" to greater profits. Send for yours today. FREE!

## RADOLEK

601 W. RANDOLPH, CHICAGO, DEPT. C4  
SEND ME THE RADOLEK RADIO PROFIT GUIDE FREE.

NAME .....  
ADDRESS .....  
Serviceman?  Dealer?  Experimenter?

**DOZENS of USES**  
FOR THESE  
**10 WATT WIRE WOUNDS**

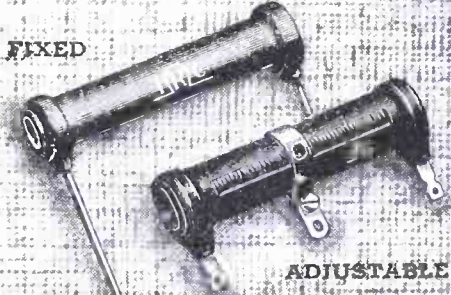

With a small stock of these famous IRC Cement Coated Wire Wounds, you're equipped for literally dozens of resistor needs. By means of the movable contact band on the adjustable units (Type ABA) ANY DESIRED RANGE up to the maximum value of the resistor may quickly be obtained. Just the thing whenever you lack a needed range in fixed type 1/2, 1 or 2-watt resistors—any size up to 10 watts. Use them universally!



**RESISTORS**

INTERNATIONAL RESISTANCE CO.  
401 N. Broad St. Philadelphia, Pa.

**.00001 Ohm to 11 Megohms**  
**SHALLCROSS**  
**Hi-Lo Resistance Bridge**

A direct reading instrument for the measurement of low resistances encountered in relay contacts, coil and armature windings, as well as other resistance of any character within the range of the bridge.

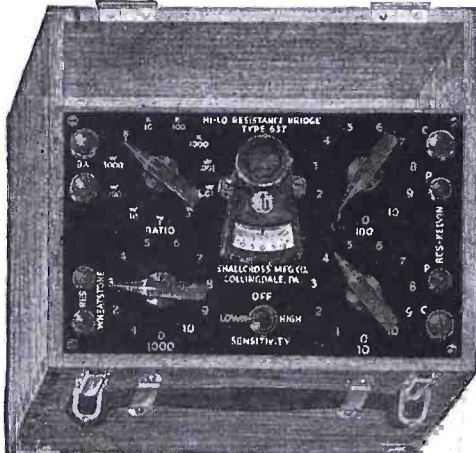

Combines in one instrument a standard Kelvin Bridge and a standard Wheatstone Bridge for measuring resistances from .00001 ohm to 11 megohms.

Send for Bulletin 637-PB.

**SHALLCROSS MFG. COMPANY**  
Electrical Measuring Instruments  
and Accurate Resistors  
700 MAC DADD BOULEVARD  
COLLINGDALE, PA.

**"HURRICANE" STATIC!**

(Continued from page 603)

improving apparatus and devising a suitable technique of observation that stations were set up during the past year at the University of Florida and the University of Puerto Rico.

Whether all storms send out such radiation is not definitely known. Certainly, from visible lightning, there will emanate an aperiodic (un-tuned) discharge. Whether similar discharges are produced in connection with all tropical disturbances remains to be determined. Nor can it be said that visible lightning is the sole source of atmospherics which can be detected by the radio *goniometer* or direction finder. Therefore, it seemed advisable to determine whether radiations, which could be detected, were associated with tropical disturbances. The following data indicate that from directions corresponding to the location of a hurricane such radiations are obtained.

(1) Knowing the approximate position of the storm with reference to the observing station, it should be possible to select radiations coming, apparently, from that general direction. (2) From similar observations made at other stations, the probable position of the storm might then be obtained by the method of triangulation. (3) The location of the probable source of each individual static crash associated with the storm might also be determined. (4) Furthermore, from such data several storms might be shown to occur simultaneously.

The apparatus, Fig. A, used in these experiments is based primarily upon that developed by Watson-Watt in 1926, and much of it was built under his direction for the U. S. Navy.

It consists essentially of 2 vertical loops, placed in planes mutually perpendicular. Each loop, Fig. B, is connected to an amplifier. The output of each amplifier is then impressed across the deflecting plates of a cathode-ray oscilloscope, resulting in a fluorescent line, or deflection, appearing on the screen of the tube when the loops are excited. Photographs of this screen are taken by means of a specially-constructed camera. These are studied for correlations between the angles of the deflections observed and the azimuths of received atmospherics. A block diagram, Fig. 1, shows the general arrangement of the apparatus.

The general procedure used in analyzing the photographs was to determine whether any ray could be found in the approximate direction in which the hurricane was known to be. In some cases, apparently such a ray (at dot, in insert, Fig. B) could be readily discerned because of its predominance.

In conclusion, although this method has not yet been developed to the point where successful and accurate forecasting is always possible, it looks promising, and, as improvements are made, it is probable that the Weather Bureau may secure data from this apparatus which will greatly augment that received from other sources.

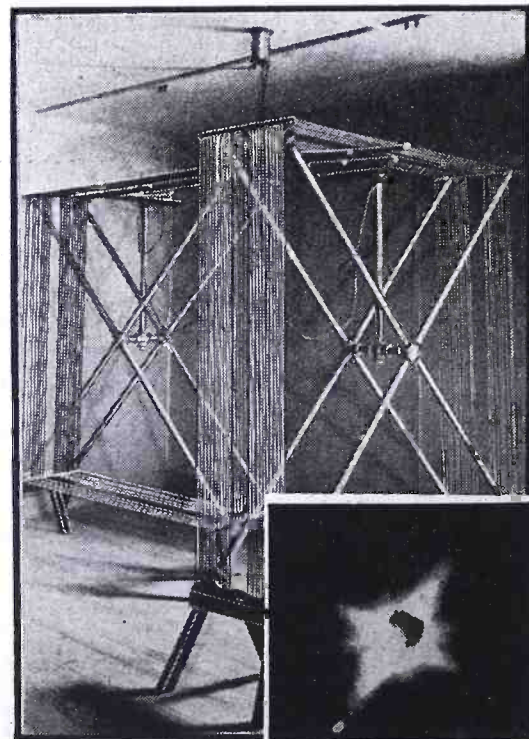

Fig. B. The two perpendicular vertical loops.  
Please Say That You Saw It in RADIO-CRAFT

**ADVERTISERS' INDEX**

<b>A</b>	
Aalloy Transformer Co., Inc.	634
Aerovox Corporation	632
Allied Radio Corporation	619
Amplifier Co. of America	636
Amplitone Products Co.	634
Arrow Sales Company	636
<b>B</b>	
Brush Development Company	632
Buffalo Sales Company	618
<b>C</b>	
Carron Mfg. Company	629
Central Radio Laboratories	618
Classified Section	624
Cornell-Dubilier Corp.	629
Cornish Wire Company	634
Coyne Electrical School	577
<b>E</b>	
Electrad, Inc.	636
Electric Institute	620
Electro-Dyne Mfg. Co.	636
Electronic Products Co.	635
<b>G</b>	
General Cement Mfg. Co.	634
General Electric Company	Back Cover
Goldentone Radio Company	618
Grenpark Company	639
<b>H</b>	
Hammarlund Mfg. Company	622
Hygrade-Sylvania Corp.	635
<b>I</b>	
Illinois Condenser Co.	634
Industrial Amplifier Systems Co.	622
International Resistance Co.	640
<b>K</b>	
Kenyon Transformer Co., Inc.	637
<b>L</b>	
Lancaster, Allwine & Rommell	635
Lincoln Engineering School	634
<b>M</b>	
Metal Cast Products Company	634
Midwest Radio Corporation	622
Million Radio & Tel. Labs.	629
Modell	634
Morse Electrical Specialties Co.	636
<b>N</b>	
National Radio Institute	579
National Schools	618
National Union Radio Corp.	621
<b>O</b>	
D. W. Onan & Sons	634
<b>P</b>	
Paramount Products Company	632
The Plan Shop	638
Precision Apparatus Corp.	625
<b>R</b>	
RCA Institutes, Inc.	622
RCA Mfg. Company, Inc.	613
Radio & Technical Publ. Co.	Inside Back Cover
Radio & Television Institute	635
Radio Circular Company	624
Radio City Products Company	634
Radio Publications	638
Radio Service Institute	624
Radio Training Assoc. of America	619
Radolek Company	639
Raytheon Production Corp.	616
Readrite Meter Works	627
Remington Rand, Inc.	637
John F. Rider	580
<b>S</b>	
S. O. S. Corporation	634
Lester L. Sargent	638
Shallcross Mfg. Company	640
Solar Mfg. Company	623
Sprague Products Company	636, 637
Sprayberry Academy of Radio	614
Stroblite Company	634
Superior Instrument Co.	622
Supreme Instrument Corp.	Inside Front Cover
<b>T</b>	
Tavella Sales Company	637
Teleplex Company	634
Terminal Radio Company	623
Trimm Radio Mfg. Company	634
Triplett Elec. Instrument Co.	631
Try-Mo Radio Co., Inc.	636
<b>W</b>	
Montgomery Ward & Co.	615
Wellworth Trading Co.	628
Weston Elec. Instrument Corp.	617
Wholesale Radio Service Co.	623
Wright-DeCoster, Inc.	639
<b>Z</b>	
Zephyr Radio Company	632

(While every precaution is taken to insure accuracy, we cannot guarantee against the possibility of an occasional change or omission in the preparation of this index.)

# 2,199 ways to GET OUT OF A RUT!

## Service Men:

**HERE IS A BOOK THAT WILL TURN YOUR SHOP INTO A GOOD-PAYING BUSINESS**

We all get into ruts. But we don't all get out of them. Those who do get out are *successes*. Those who don't are *failures*. That is the blunt truth about the radio servicing business and we might as well face it honestly.

To make a real success in business today the radio service man must *keep out of the ruts*. He must be alive, alert, on his toes every second, one step *ahead* of the other fellow. He must be just as good a *business man* as he is a *service man*.

### A book about YOUR business

Up to the present it has not been easy for the technically-trained radio man to master the essentials of modern business. *But now—any* service man can easily learn the most effective and economical ways to build up volume and profits, to *make money quickly*. He can use in his own business the very plans, ideas and methods used by the most successful radio organizations in the country—ideas that have produced thousands of dollars worth of business before, that will produce many thousands more for those who use them in the future.

### What this book will DO for YOU

These ideas, plans and methods—2,199 ways to get out of a rut—they're all put together in one big book. A book of business information obtained from practical men by practical men for practical men. A book that tells you *everything* you want to know about the business side of your profession—WHAT to do and HOW to do it! *Complete . . . Authoritative . . . Up-to-date . . . a typical Ghirardi book*. And it's all made so clear and simple that you can put it to work making money for you the very day you get the book!

Just picture to yourself the effect this invaluable knowledge will have on your own business! *Let's all get out of the ruts and get that business we should have*. Mail the coupon—or postcard—today for a FREE CIRCULAR telling you all about it!

With over 400 pages and 200 illustrations this great book tells you just exactly what to do to build up your business—how to advertise, how to sell, how to get free publicity, how to "merchandise," how to run a business profitably. It gives actual examples of order-pulling ads, sales letters, postcards, etc., which you can use for yourself. It applies to the sale of radio servicing, new sets, Auto Radio, P. A. work, home electrical and radio appliances, etc.

*It's positively the first and ONLY book of its kind!*

## RADIO BUSINESS

*Promotion and Management*

by A. A. Ghirardi and T. S. Ruggles

**OVER 400 PAGES—OVER 200 ILLUS.**

**FREE**

**CLIP and MAIL**

**Today**

**RADIO & TECHNICAL PUBL. CO.**  
Dept. RC-47  
45 Astor Pl., New York

Please send me free circular BB describing the book in full. Also the free "Radio Business Barometer."

Name .....  
Address .....  
Occupation .....

**Free Circular**

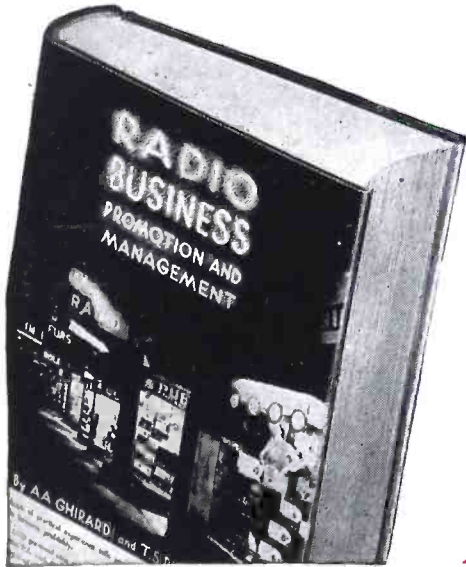

With all these **PRE-TESTED IDEAS** you can't help **MAKING MONEY!**

### HOW TO SELL

Why people buy. Market analysis. How to get leads and prospects. How to get people into your store. Principles of selling. Demonstrations. Store selling. Selling by phone. Outside selling—how to get by the door—following up leads. Selling talks. Sales resistances and how to break them down. Making business contacts.

### HOW TO ADVERTISE

How to plan your promotional program. How much to spend. Costs. How to write your advertising. Tested appeals. How to get action. Preparation and production. Forms of advertising—Display—Direct Mail—Newspaper—Broadcast—Phone Book—Other media. Publicity. Merchandising. Premiums, Logs, Contests, etc. Follow-ups.

### BUSINESS METHODS

How to set yourself up in business. Shop equipment. Store layout. Managing the business. Employee and customer relations. Financial data. Bookkeeping and accounting. Instalment financing. Collections. Sales and service forms and records. House policies. Sidelines.

**A Million Dollars' Worth of Ideas and Experience FOR YOU!**

**FOR DEALERS AND SERVICE MEN**

# Everything ABOUT RADIO Servicing IN 2 BIG BOOKS

Ghirardi's famous MODERN RADIO SERVICING, together with the companion book, RADIO FIELD SERVICE DATA, give you a permanently up-to-date reference library for practical radio service work. MODERN RADIO SERVICING (1300 pages—706 illus.) gives you a thorough instruction course in radio servicing as it is most successfully practised today. RADIO FIELD SERVICE DATA (436 pages—107 illus.) gives you all the essential job data you need for shop and field use, and is kept up to date with Supplements issued twice a year. Here's a small part of what these 2 great books will give you:

### TEST INSTRUMENTS

Complete explanation of all kinds of radio test equipment. Principles of operation and design. Description of latest commercial models, with circuit diagrams. Construction data, etc.

### SPECIAL SERVICING PROBLEMS

Auto Radio installation and servicing. Location and elimination of noise and interference in All-Wave sets. High Fidelity sets. Etc.

### SERVICING METHODS

Latest test and repair methods. Receiver analysis. Individual components. Aligning sets with test oscillators and by latest Cathode-Ray Oscilloscope methods. AVC and QAVC circuits. All clearly explained in detail with copious diagrams, etc.

### FIELD DATA

"Case Histories" of over 1,500 receivers, with trouble symptoms and remedies for each. I.F.'s for 5,424 superhets. Automobile electrical wiring diagrams and ignition interference data. Troubleshooting chart. RMA Color Codes, wire tables, etc.

**A Double-Barrelled Combination!**

## MODERN RADIO

*Servicing*  
**\$4 alone**

*Together with 436 p.*

**RADIO FIELD SERVICE DATA**

**\$6**



To: Radio & Technical Publ. Co.  
Dept. RC-47  
45 Astor Pl., N. Y.

Enclosed find \$6 for Combination Offer, including Jan. & June 1937 Supplements to DATA BOOK.

Please send free circulars (S).

Name .....  
Address .....

**MAIL TODAY!**

**Also—RADIO PHYSICS COURSE—\$4**

GENERAL  ELECTRIC

# AUTO RADIO

WITH

## Safety Tuning

You can have music wherever you go with a G-E Auto Radio. See your G-E Auto Radio dealer for a demonstration of Model FA-80 — the only auto radio equipped with **AUTOMATIC FREQUENCY CONTROL**. It's auto radio's new safety tuning feature. You concentrate your eyes on the road, for "safety first" in driving, while AFC permits instantaneous tuning for perfect Focused Tone reception. There are **THREE** attractive and modern G-E Auto Radio Models to choose from. And for best results — install a G-E Auto Antenna on your car.

**GENERAL  ELECTRIC**  
**AUTO RADIO**

APPLIANCE AND MERCHANDISE DEPARTMENT, GENERAL  
ELECTRIC COMPANY, BRIDGEPORT, CONNECTICUT

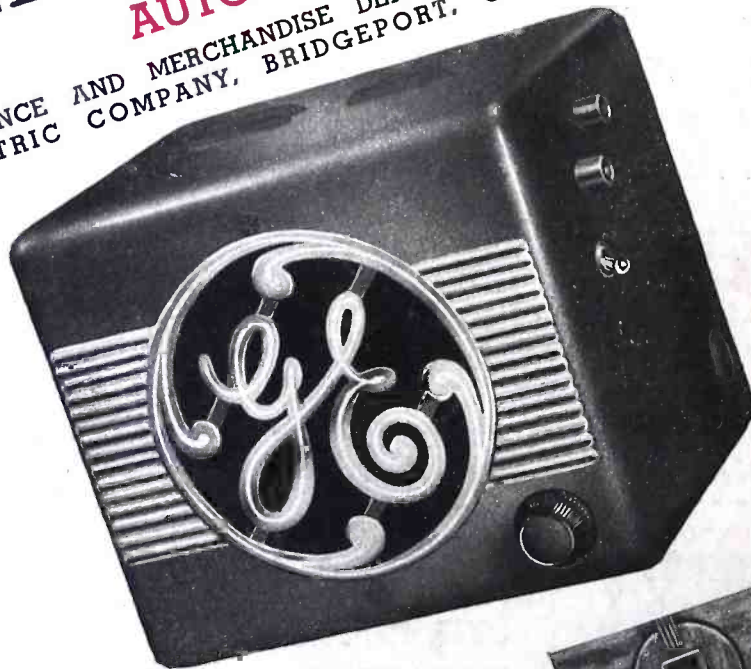

"CUSTOM-BUILT" INSTRUMENT PANEL CONTROLS  
FOR ALL NEW MAKES OF CARS

